

FILM REVIEW BOOK 3002 and 3003

POWER STEERING PUMP DIAGNOSIS and TESTING

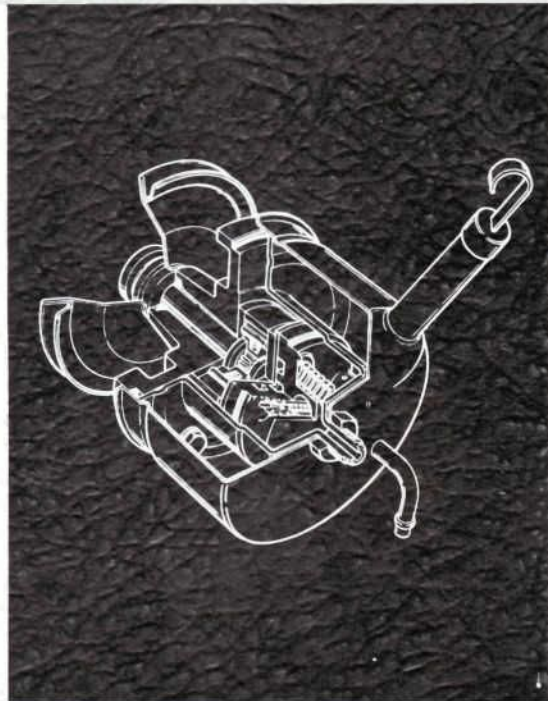

VOL. 69 S2 L2A

POWER STEERING PUMP DIAGNOSIS AND TESTING

FILM REVIEW READY REFERENCE HANDBOOK 3002 and 3003
VOL. 69 S2 L2A

TABLE OF CONTENTS

	Page
INTRODUCTION	
DESCRIPTION	1
DIAGNOSING A POWER STEERING PUMP COMPLAINT	2
THREE BASIC PROBLEMS	3
• External Leakage	3
• Pump Noise	7
• Insufficient Pump Pressure	11
NEW TEST EQUIPMENT	11
HOW TO CONDUCT A PUMP FLOW TEST	13
HOW TO CONDUCT A PUMP PRESSURE RELIEF TEST	15
CAUSES OF LOW OUTLET PRESSURE	15
SPECIFICATIONS	19

The descriptions, testing procedures, and specifications in this handbook were in effect at the time the handbook was approved for printing. Ford Motor Company reserves the right to discontinue models at any time, or change specifications, design, or testing procedures without notice and without incurring obligations.

NATIONAL SERVICE OFFICE
FORD DIVISION



FIRST PRINTING—NOVEMBER, 1968

© 1968 FORD MOTOR COMPANY

DEARBORN, MICHIGAN

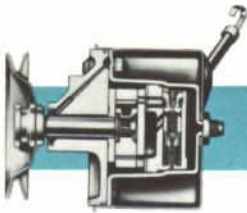

INTRODUCTION

INTRODUCTION

The techniques described in this handbook will enable the Ford Service Technician to service Ford-design power steering pump problems that come to his attention.

Through careful study of the information contained in this handbook and in your applicable Shop Manuals, you should be able to:

- Diagnose common power steering pump problems.
- Understand and perform critical power steering pump testing and inspection procedures.
- Understand and perform important power steering pump assembly procedures.

This handbook describes the three most basic power steering pump problems, describes the new test equipment, how to conduct pump flow and pressure relief tests, and outlines the major causes of high and low outlet pressure. In addition, charts and specifications for the 1969 Ford-design power steering pump are included.

DESCRIPTION

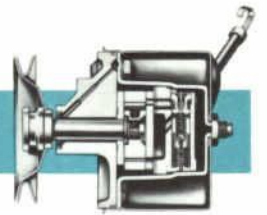

DESCRIPTION

Each Ford-design power steering pump has an identification tag to identify the assembly for service purposes . . . The tag is located on the outlet fitting and is fastened by a reservoir retaining nut. Each tag has the date code, service model identification and the manufacturing plant shift code enscribed.

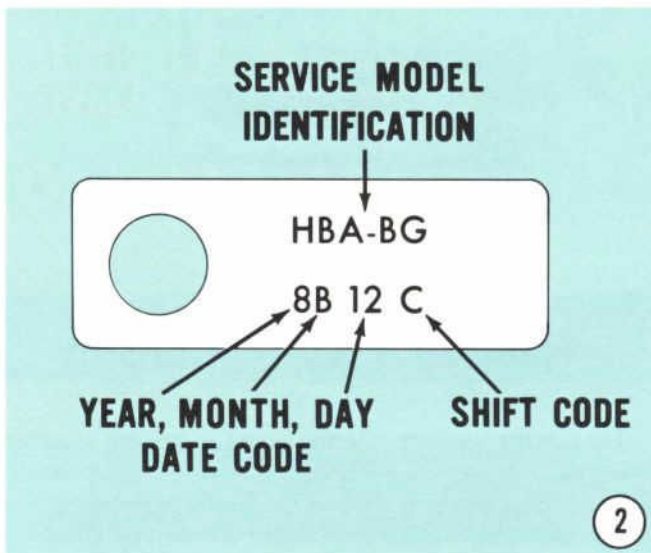

The Ford-design power steering pump is a belt-driven slipper-type pump integrated or combined with the reservoir.

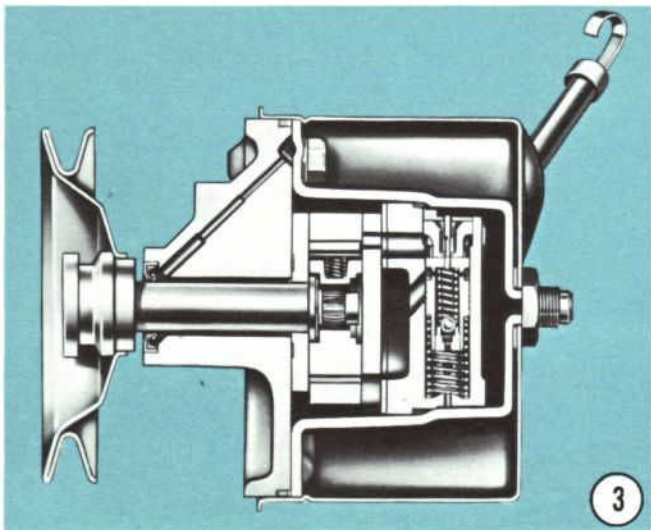

The reservoir is attached to the rear side of the pump housing front plate, and the pump body is encased within the reservoir.

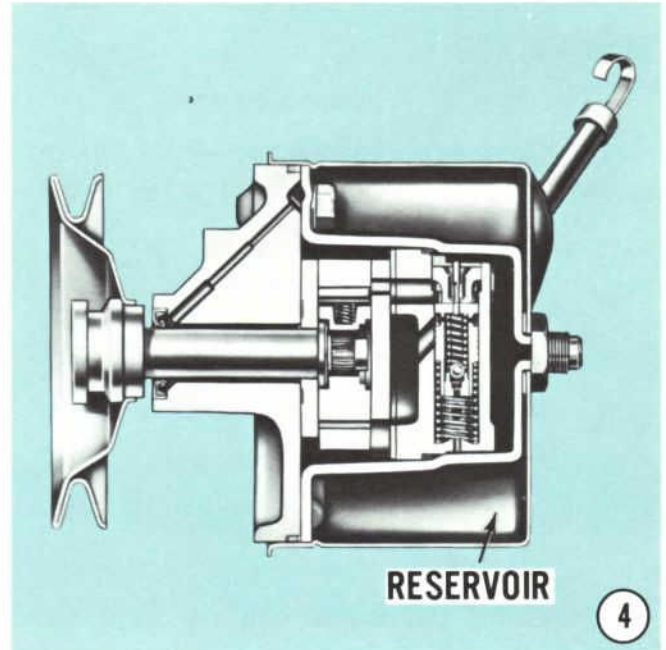

The pump rotor has 8 slippers and springs rotating inside a cam insert.

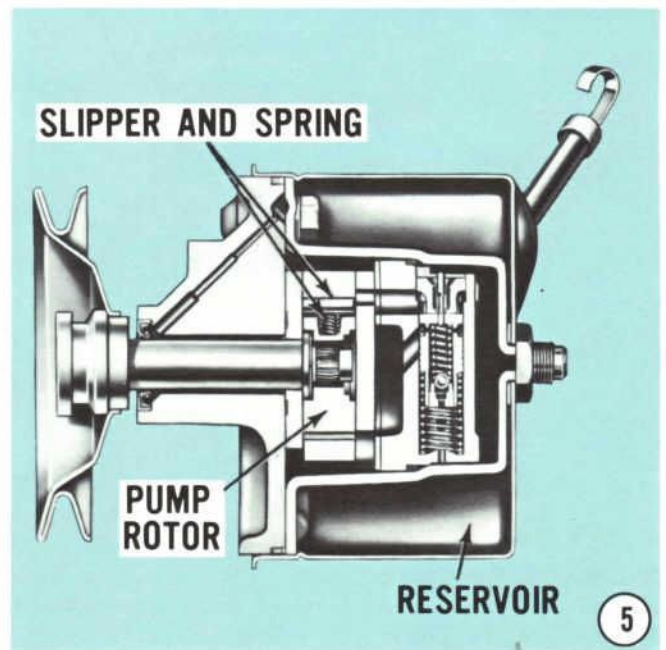

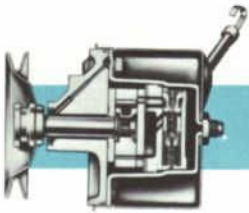

DIAGNOSING A POWER STEERING PUMP COMPLAINT

Internal flow is accomplished by a variable orifice mechanism.

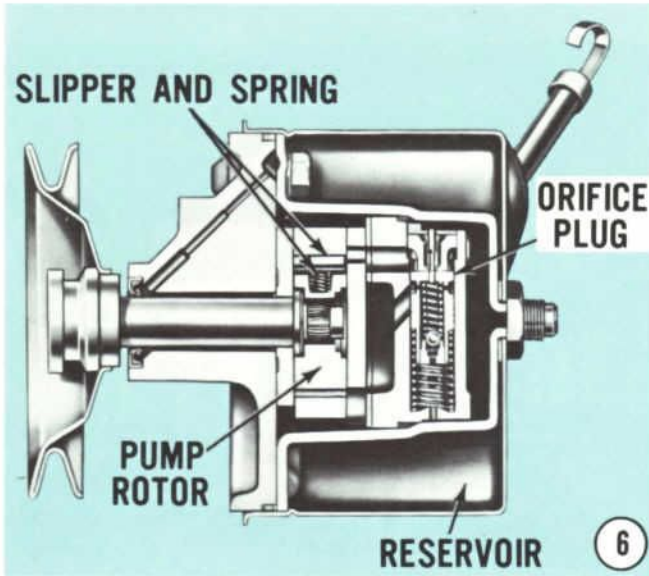

The metering pin travels with the spool valve, decreasing the area of the orifice (opening) at higher speeds to reduce flow to the steering gear.

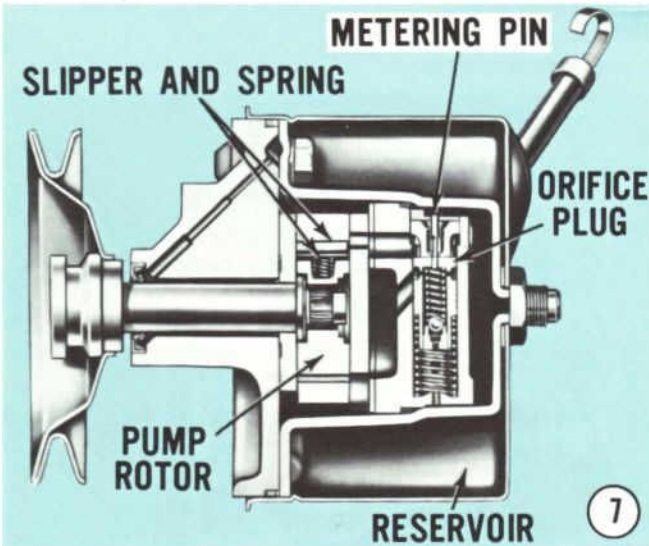

The relief valve limits pressure at left or right stop positions of the steering wheel. The applicable Shop Manual provides a description of the components of the power steering pump.

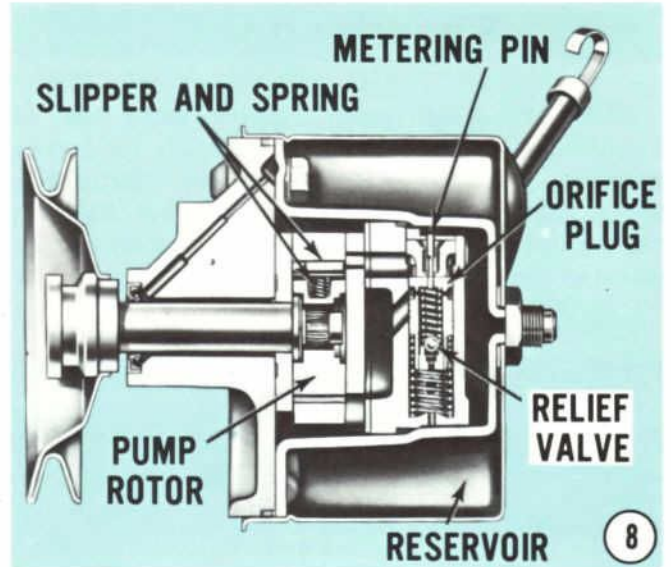

DIAGNOSING A POWER STEERING PUMP COMPLAINT

Diagnosing a power steering pump complaint requires that you properly quiz the customer to get his description of the problem. Now that Ford dealerships are responsible for servicing power steering pumps, you will have to consider the basic problems behind the improper operation of these pumps and verify the complaint.

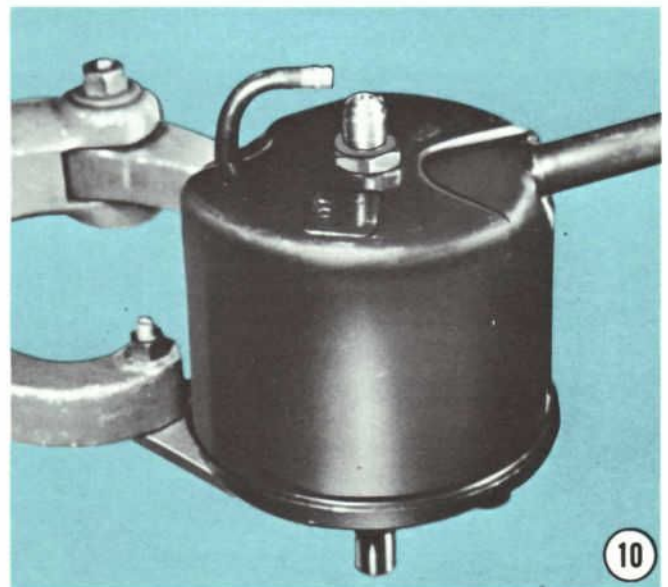

THREE BASIC PROBLEMS

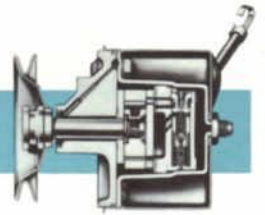

THREE BASIC PROBLEMS

There are three basic problems that may require a partial or complete overhaul of the pump. They are:

- external leakage
- pump noise
- insufficient pump pressure

EXTERNAL LEAKAGE

External leakage can be caused by a variety of problems:

FALSE LEAKAGE

Always check for indications of false leakage first. If the reservoir has been overfilled, or the steering wheel has been turned with the engine off, fluid could be forced out of the filler tube and deposited on the outside of the pump.

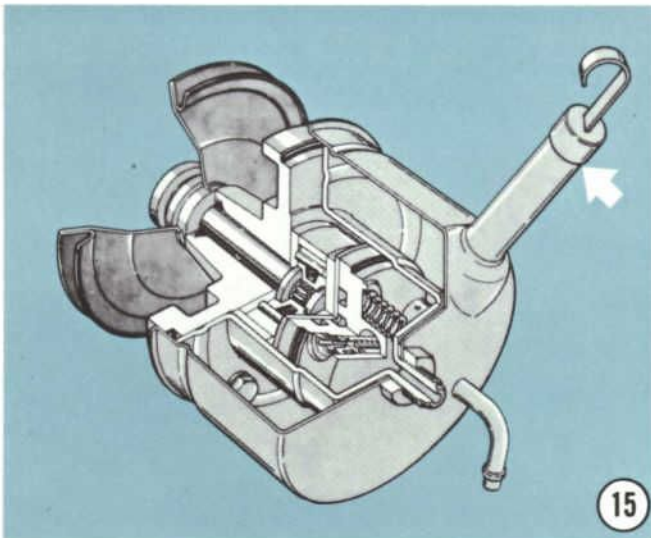

LEAKAGE AT CAP AND DIPSTICK ASSEMBLY

Leakage can occur at the top of the filler tube if the cap and dipstick assembly is improperly installed, damaged or lost. Replace the dipstick and cap assembly, if required. Always make sure the dipstick and cap assembly is installed securely.

LEAKAGE THROUGH BRAZING

When there's leakage through the brazing at the filler neck or return tube at the reservoir, replace the reservoir.

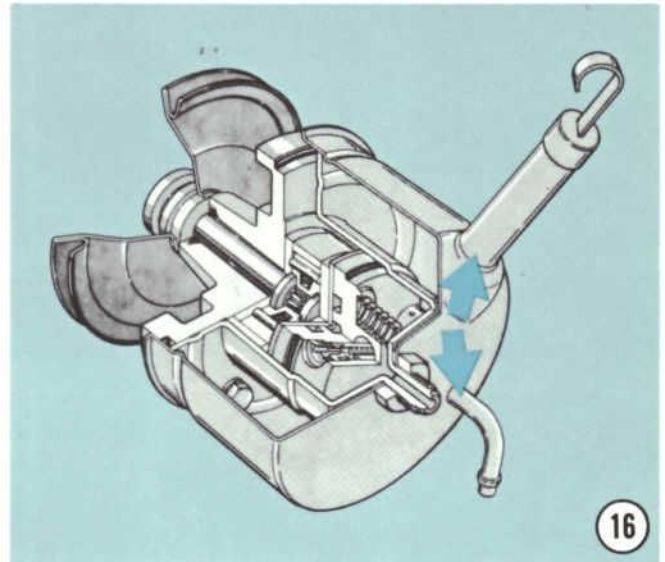

LEAKAGE BETWEEN RESERVOIR AND HOUSING PLATE

External leakage between the reservoir and housing plate can be caused by the following conditions:

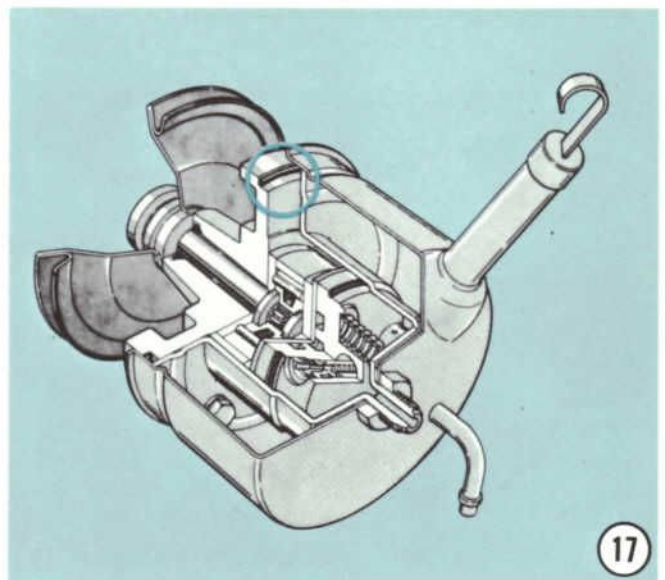

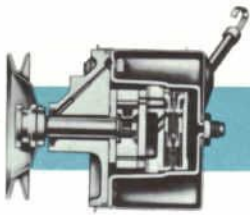

THREE BASIC PROBLEMS

Foreign Material and Damaged Seals

Foreign material, such as metal chips on the reservoir O-ring seal or in the seal area, are likely causes of external leakage. A damaged seal or a seal out of position are other causes. Solve these problems by cleaning the seal area, replacing the seal, and making sure the seal is properly positioned.

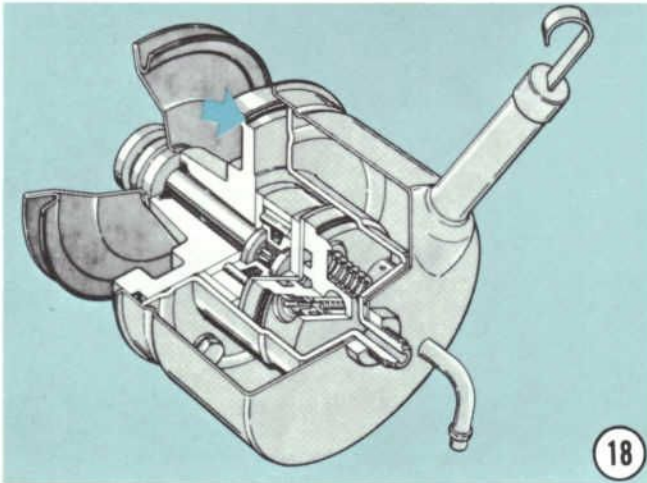

Damaged Reservoir or Housing Plate

Another reason for leakage at the reservoir O-ring seal is a damaged inside diameter of the reservoir or a damaged outside diameter of the housing plate. There must be no damage to these mating surfaces. If there is, the damaged part must be replaced.

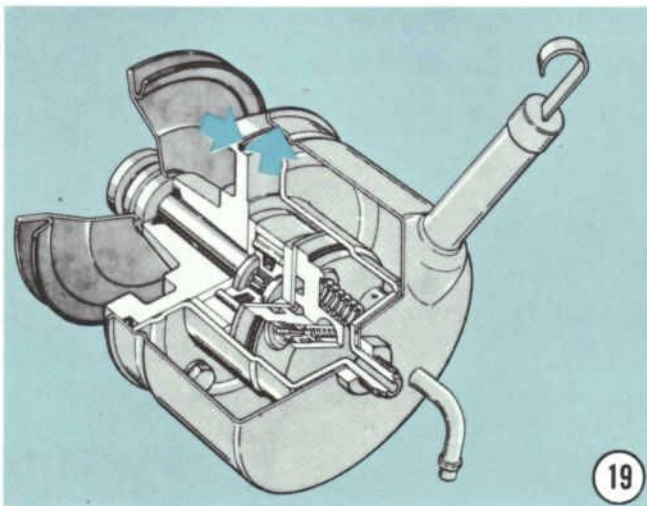

Out-of-Round or Oversized Reservoir

There may be a remote possibility that the reservoir is out-of-round or oversized. Once again, replacement of the reservoir is necessary, to correct these conditions.

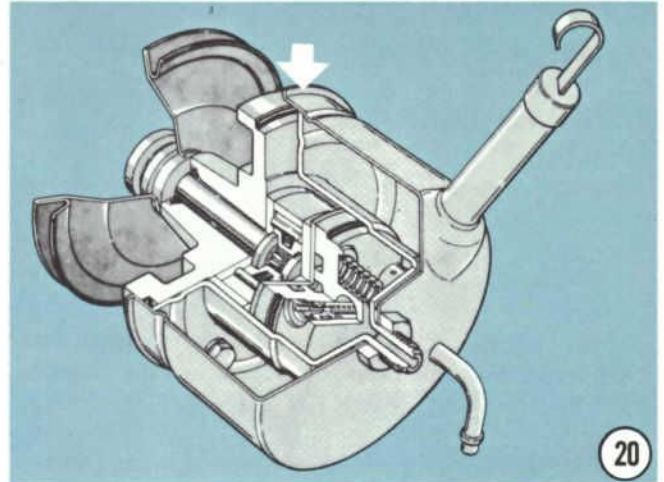

Remember, every time the reservoir is disassembled from the pump, use a new reservoir O-ring seal for assembly.

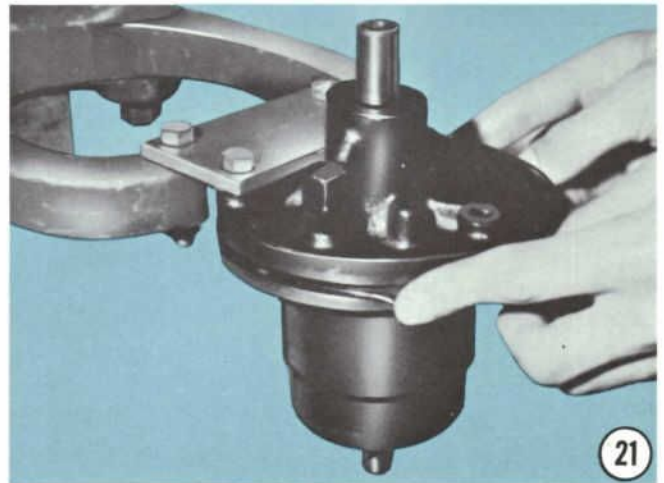

External Leakage at Outlet Fitting

External leakage may be observed at the area of the outlet fitting. Close inspection may indicate that the fitting is improperly assembled.

THREE BASIC PROBLEMS

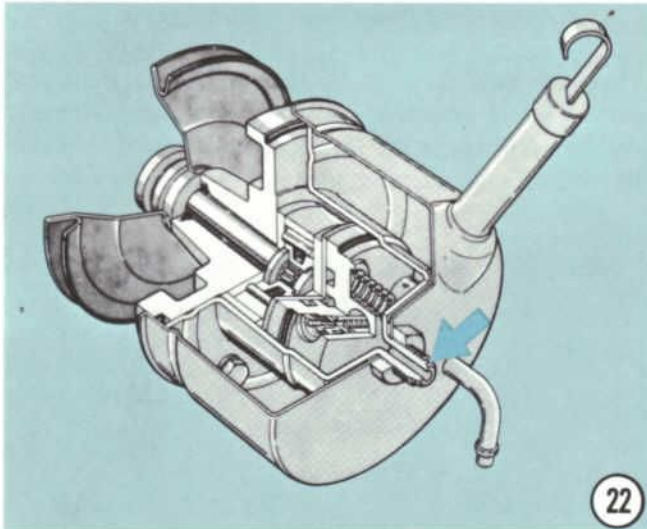
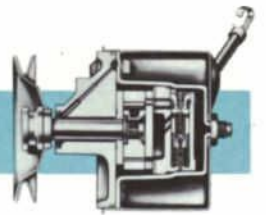

External Leakage at Outlet Fitting Nut

Leakage at the outlet fitting may be caused by insufficient torque on the outlet fitting nut. To remedy the condition, torque the nut to specifications. Be sure the specified 47 foot-pound limit is **not** exceeded!

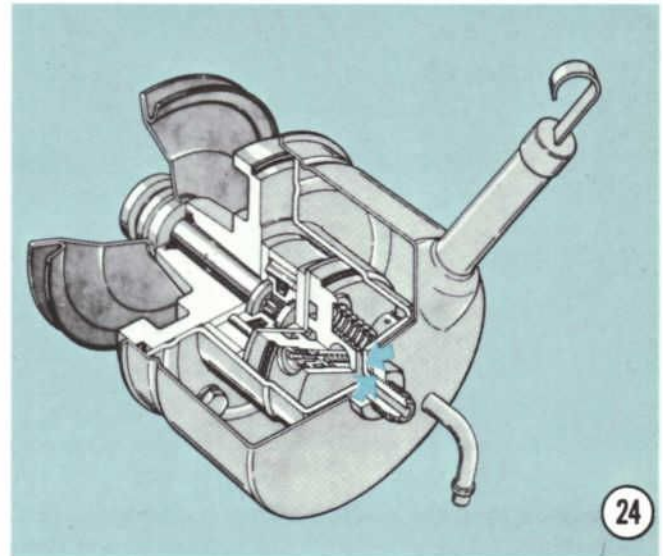

Damaged Housing-Reservoir Gasket

The gasket between the housing and the reservoir may have been damaged before or during assembly. A damaged gasket **must** be replaced. This gasket should **also** be replaced every time the housing and reservoir are disassembled.

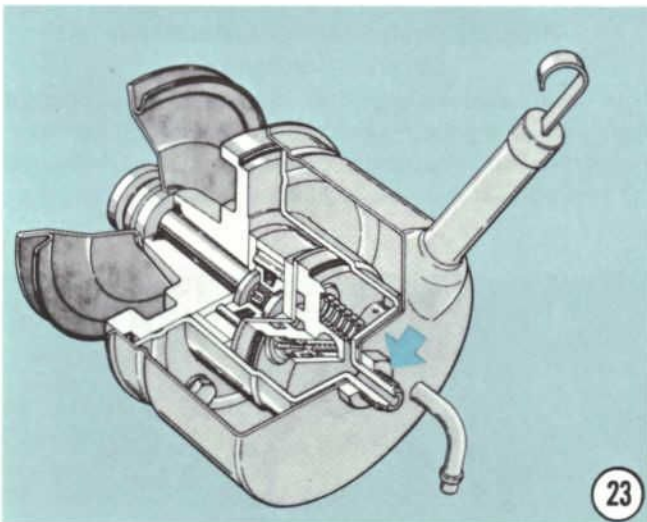

Damaged Reservoir and Pump Housing Surfaces at Outlet Fitting

External leakage can be caused by damaged sealing surfaces on the inside of the reservoir and the outside of the pump housing at the outlet fitting gasket. Replace the part(s) with the damaged sealing surface(s).

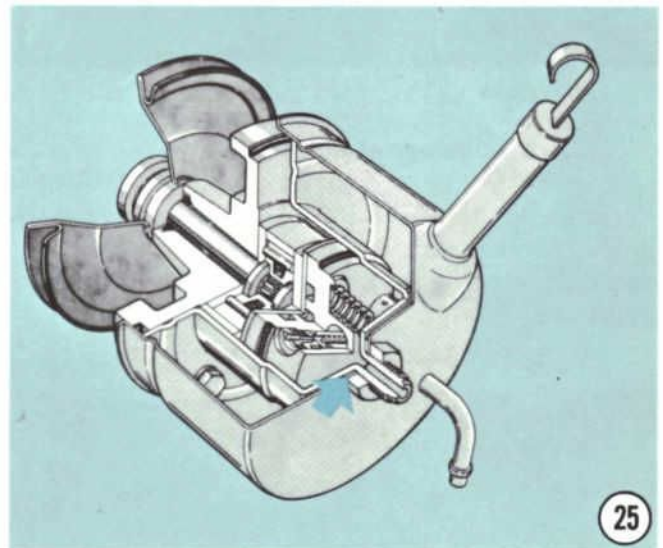

Shaft Seal Leakage

Leakage at the pump shaft seal area will occur if the shaft seal was not pressed flush with the housing.

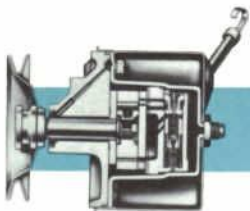

THREE BASIC PROBLEMS

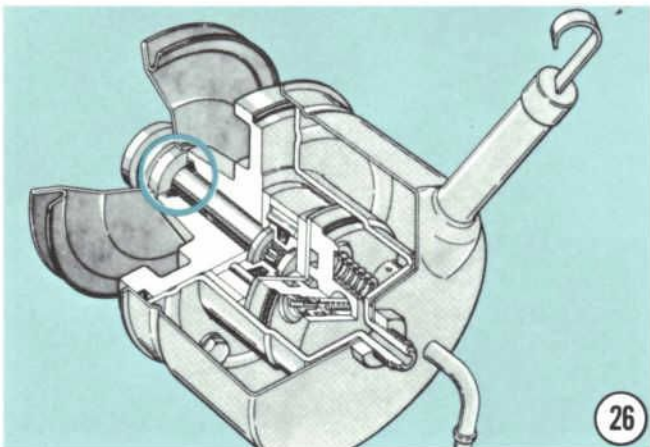

26

plate surface, or if the shaft seal lip was damaged prior to assembly.



27

Damage at Rotor Shaft

Leakage will be caused by damage at the rotor shaft outside diameter, such as helical grooving, or scratches along the axis of the shaft. In these cases, the shaft must be replaced.



28

Damaged Shaft Seal Counterbore

Leakage may occur if the bottom of the shaft seal counterbore is excessively rough or damaged. Remedy this by replacing the housing plate and bushing assembly.

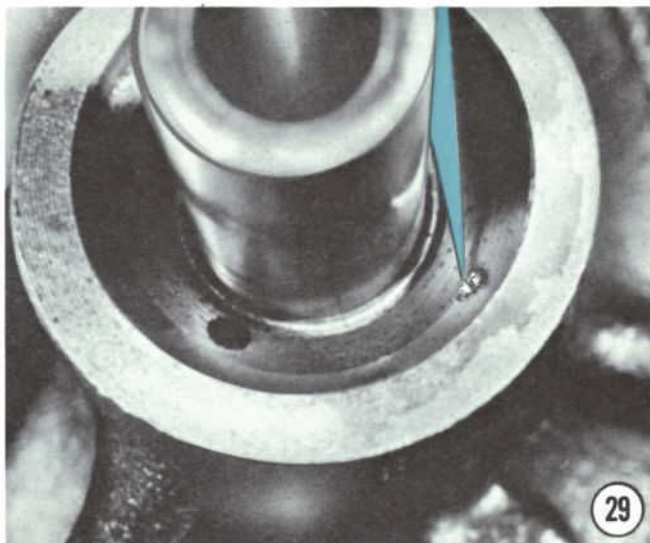

29

Plugged Shaft Seal Drain-Back Hole

In rare cases, leakage may be caused by a plugged shaft seal drain-back hole that is not drilled through. The drain-back hole must permit fluid flow back into the reservoir. If the hole is plugged, clean it. The pump

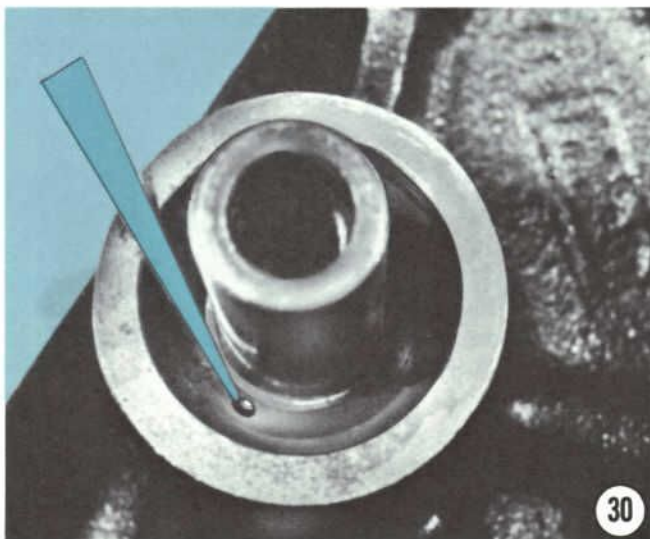

30

THREE BASIC PROBLEMS

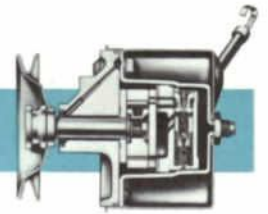

has to be partially disassembled to clean the drain-back hole properly. If the hole is not drilled through, replace the housing plate and bushing assembly.

Also, the drain-back hole in the housing may not be lined up with the hole in the housing plate due to improper assembly. Make sure the holes are properly aligned during assembly.

TO SUMMARIZE, THERE ARE FIVE SHAFT SEAL LEAKAGE PROBLEMS:

- At the seal
- At the shaft
- At the counterbore bottom
- At the drain-back hole
- At the shaft bushing

CAUTION:

Observe one major precaution when working in the shaft seal area. Prevent tool marks and scratches from crossing sealing surfaces or they will provide a "leak path" for the oil.

PUMP NOISE DIAGNOSIS

It is important to know and recognize the different kinds of pump noises so they can be diagnosed.

Swish

"Swish" is a noise created by the flow of excess fluid into the by-pass port of the pump valve housing, with the fluid temperature below 130 degrees.

The shearing effect of the heavier, cool oil is **not** harmful to pump operation and should diminish at normal operating temperatures.

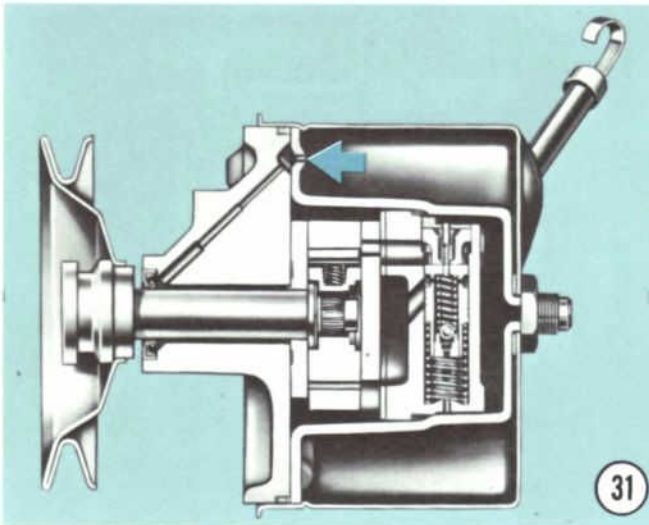

Worn Shaft Bushing

An excessively worn shaft bushing can also cause leakage around the shaft seal. Replace the housing plate and bushing assembly to correct this problem.

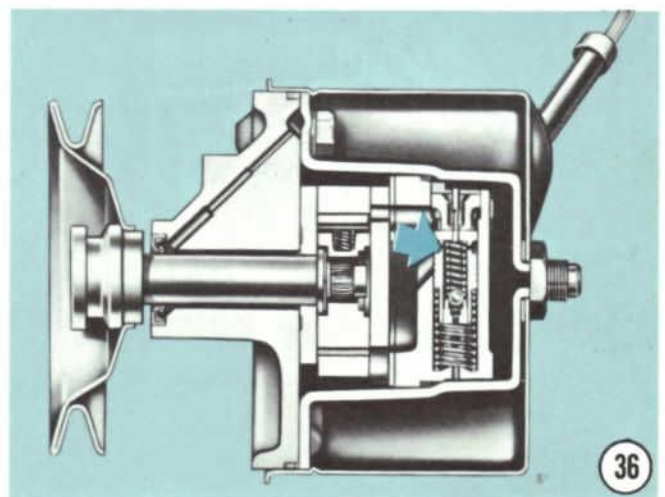

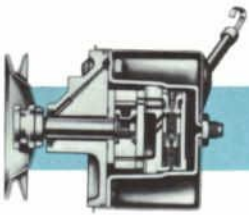

THREE BASIC PROBLEMS

Whine

“Whine” can be caused by interference of the components in the pumping element. It can also be caused by aerated fluid.

On-Center-Hiss

An “On-Center-Hiss” is caused by fluid flow passing through a damaged outlet fitting or by excessive flow. This term is used because the noise is heard with the flow control valve in an “On-Center” position.

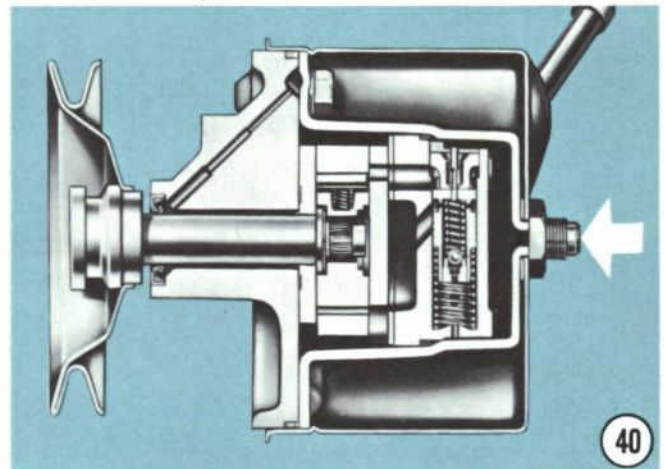
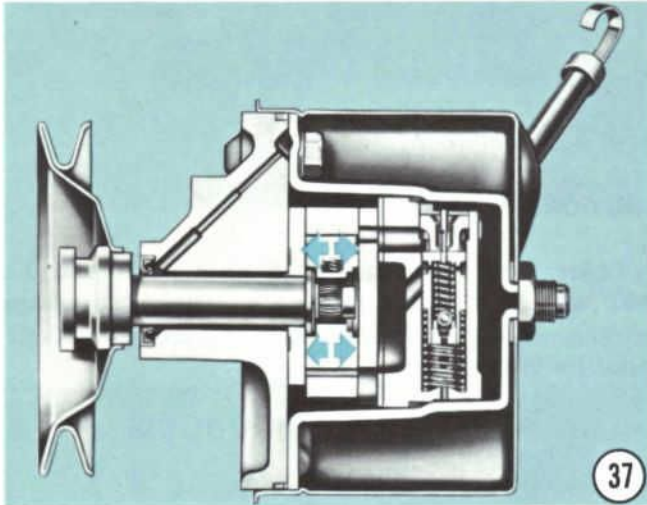

Click

A noise like a “Click” is caused by pump slippers being too long, by broken slipper springs, or by excessive wear of the pumping elements.

Chatter

“Chatter” is caused by chipped corners at the rotor outside diameter or a bent or distorted slipper spring.

NOISE DUE TO AERATED FLUID

The greatest cause of excessive pump noise is air in the fluid. Here are the conditions that produce aerated fluid:

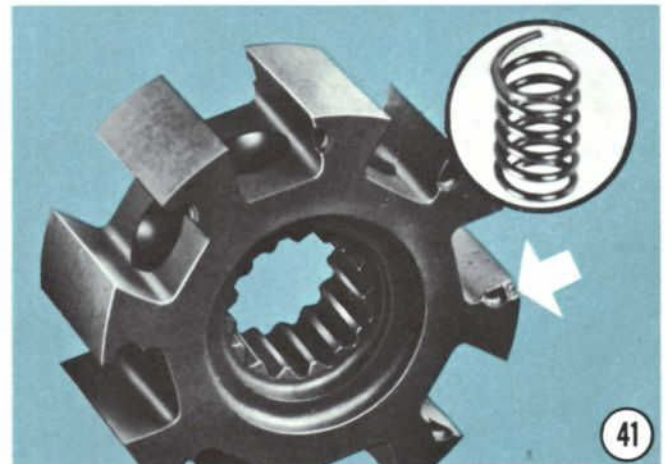
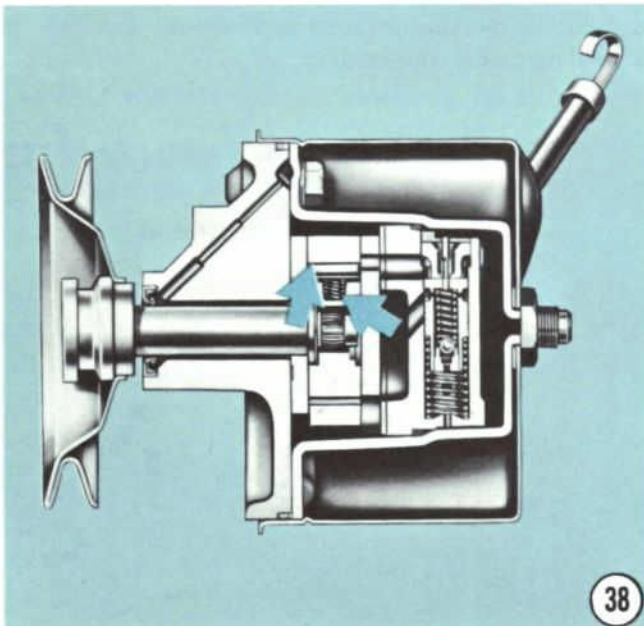

THREE BASIC PROBLEMS

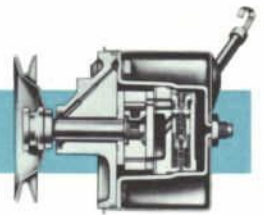

Low Fluid Level

An extremely low fluid level caused by improper fill or external leakage at any point in the power steering system will produce aerated fluid. Low fluid level should have been discovered during the preliminary diagnostic procedures, as outlined in the applicable Shop Manual.

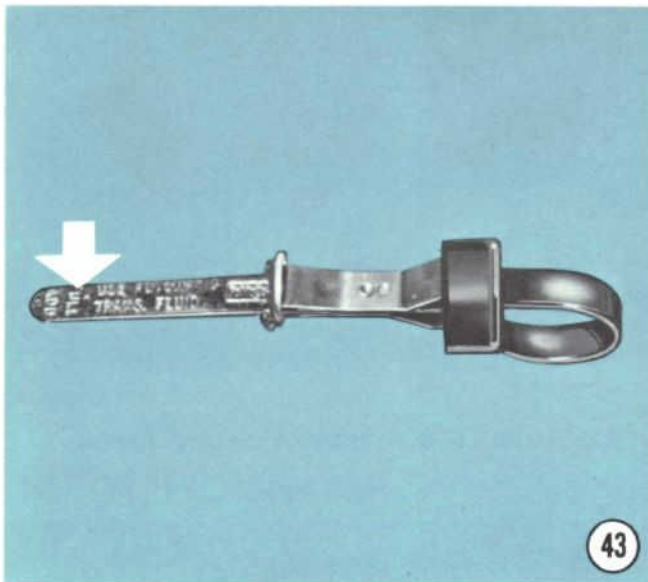

Loose, Improperly Torqued Housing-to-Plate Screws

Loose or improperly torqued housing-to-plate screws will cause aerated fluid, and resulting pump noise. Tightening of the screws to the specified torque will eliminate the cause of this problem.

To correct pump noise caused by aerated fluid, first eliminate the cause of the fluid aeration, then purge the system of air.

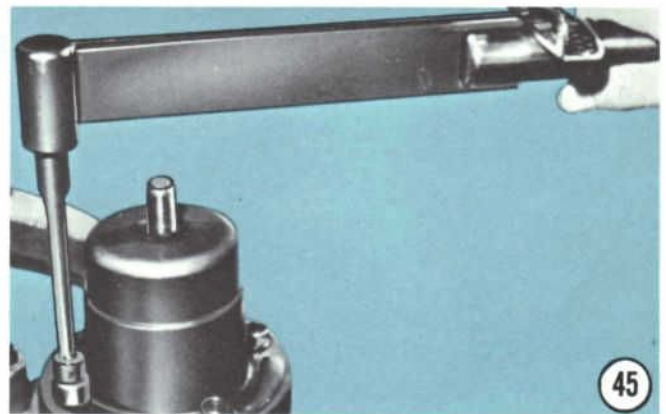

Broken Reservoir Baffle

A broken reservoir baffle will result in aerated fluid.

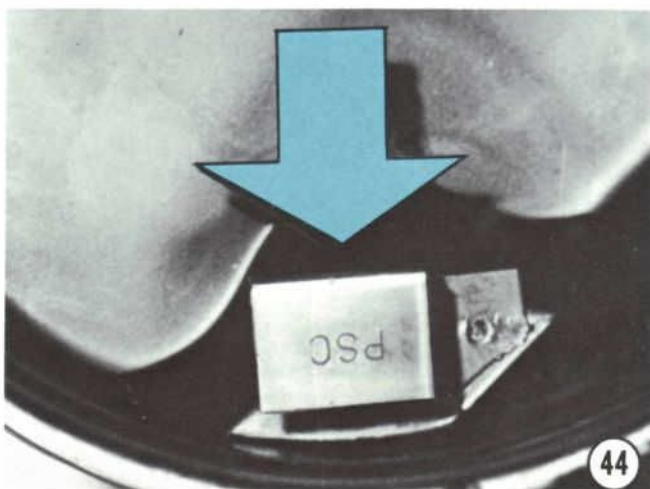

ADDITIONAL CAUSES OF NOISE

There are several other causes of excessive pump noise:

- Improper assembly of components such as slippers. For example, the slipper illustrated has been installed backward and the flat is facing in the wrong direction.



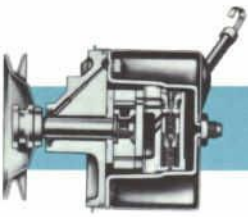

THREE BASIC PROBLEMS

- Imperfections on the rotor outside diameter or rotor end surfaces.

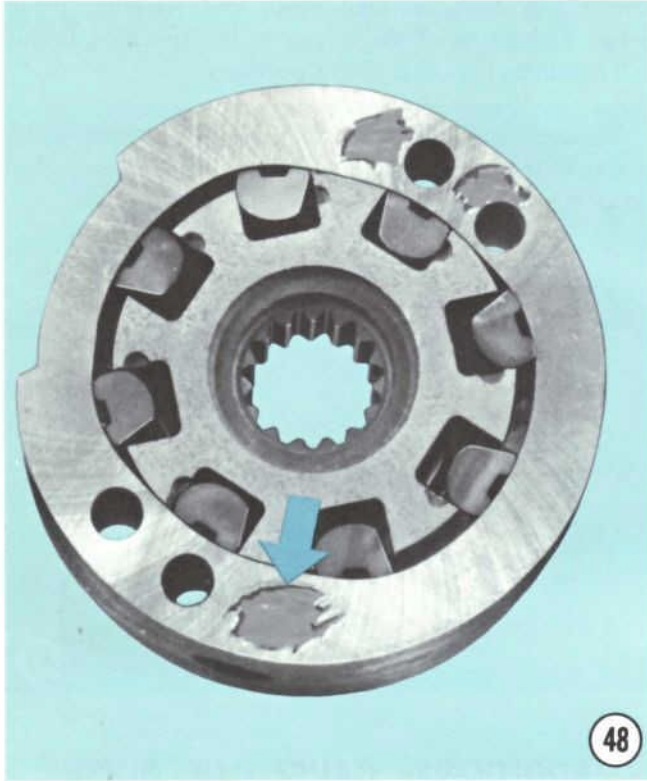

- Damaged rotor splines.

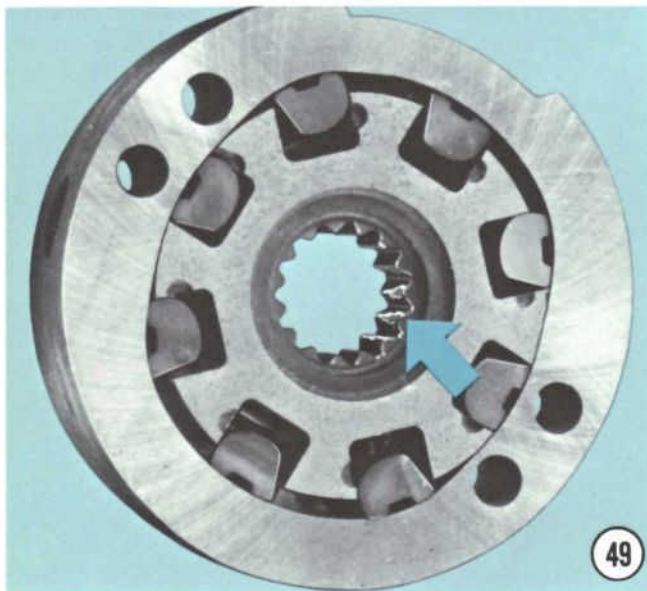

- Interference, such as a rotor hitting the cam.

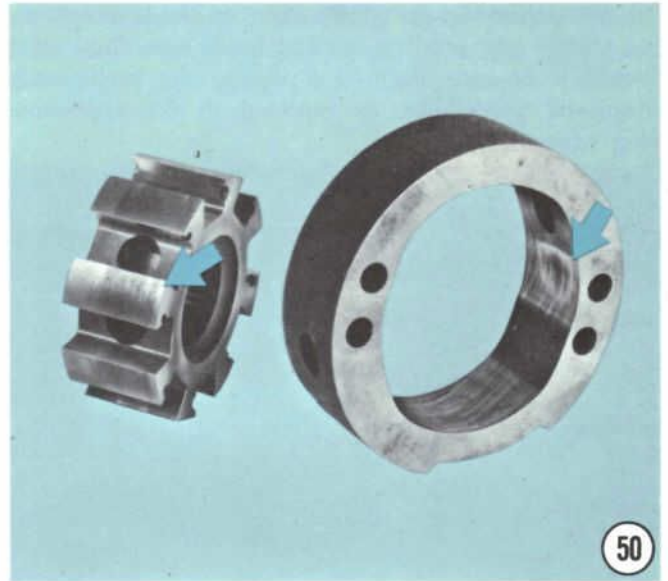

- A cam with a hairline crack on the inner surface.

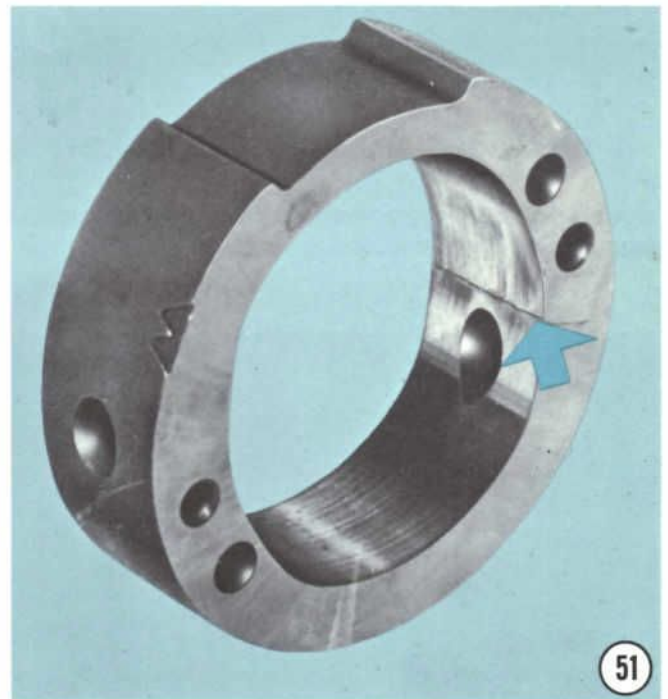

- Excessively worn or scored pumping elements and pressure plates.

NEW TEST EQUIPMENT

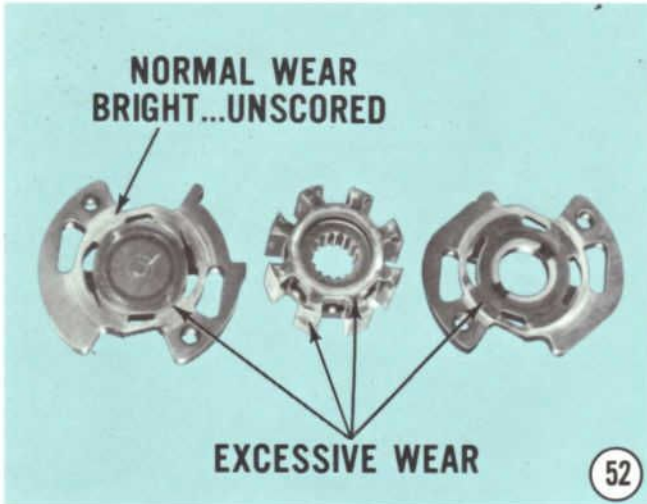
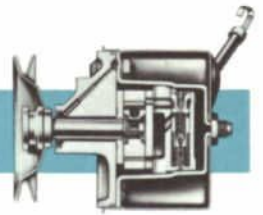

- A damaged outlet fitting orifice due to an improperly machine-ground chamfer or no chamfer on the inlet side of fitting. The hissing noise that is heard under these conditions is caused by fluid flow rather than interference of moving parts.

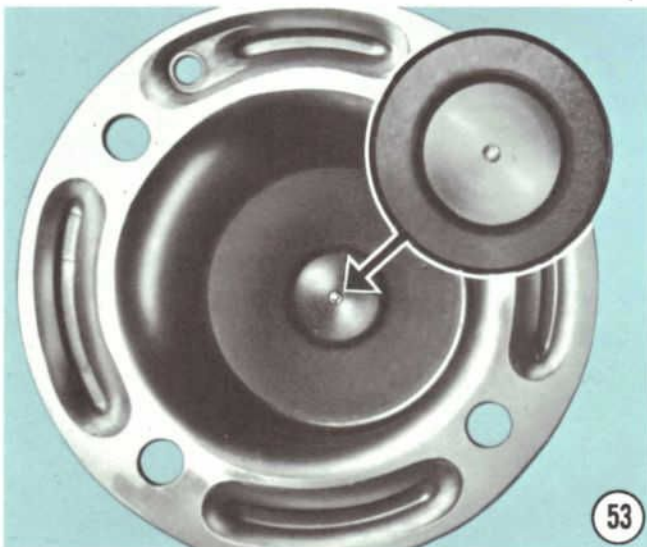

INSUFFICIENT PRESSURE

Another important pump problem is insufficient pressure. A pump flow test has been added to the diagnostic procedures, and supplements the pump pressure test. These tests help you to obtain the information needed to determine whether a power steering problem is caused by the power steering pump or to

another component, such as the steering gear or control valve.

Before pump flow and pressure are tested, the preliminary checks and adjustments of the complete system must be performed. These are unchanged from previous years. Refer to the applicable Shop Manual for the proper procedures.

Check the:

- complete system for damage or leaks.
- fluid level in the reservoir.
- drive belt tension.
- pulley sizes on engine and pump.
- tire pressures.
- correct vehicle application. Be certain the pump installed is the one specified for the vehicle.

NEW TEST EQUIPMENT

The previously used pump pressure test has now been supplemented by a pump flow test. Since the test procedures are revised, more test equipment is required. The new equipment consists of:

A **thermometer** to sense fluid temperature while the tests are performed.

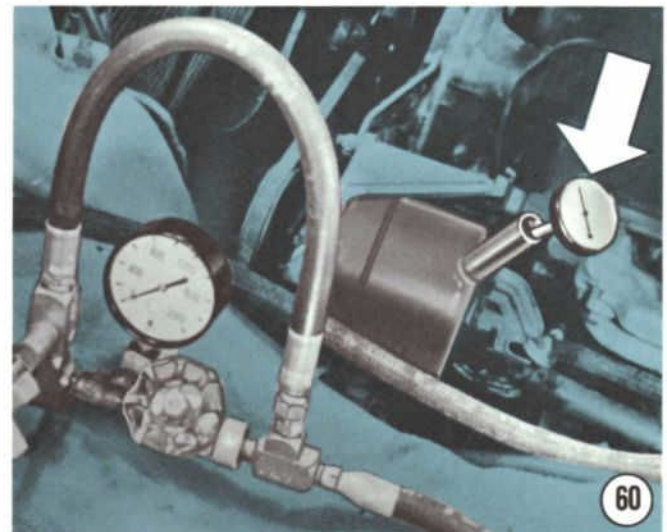

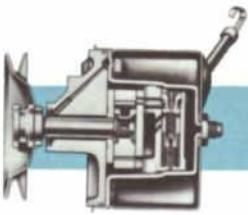

NEW TEST EQUIPMENT

An **input fitting** — stamped “input.” Plus a manual valve.

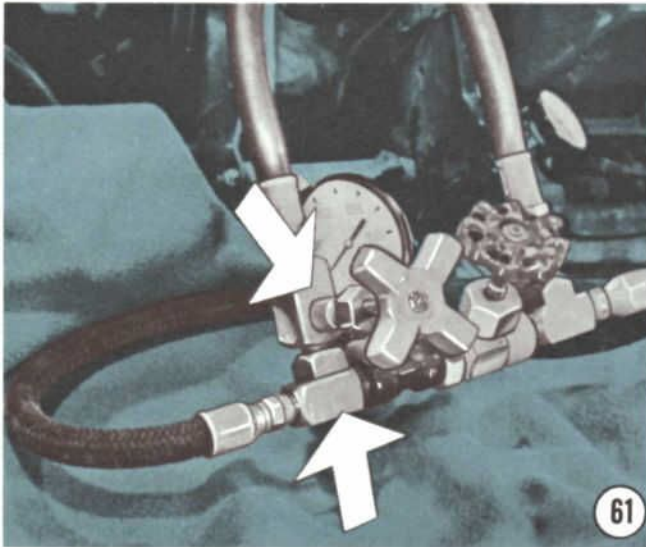

A **by-pass hose** and an **output fitting** stamped “output.”

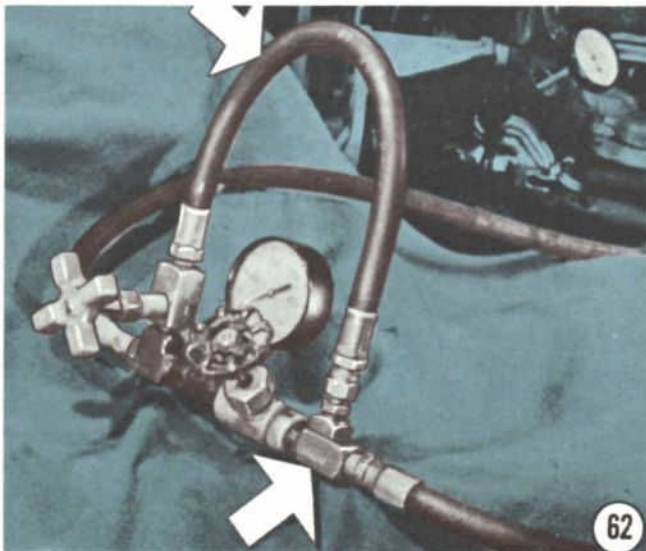

The new tool separates and isolates the power steering pump from other power steering system parts and shows the true pump conditions, free from all errors or problems which may be caused by the steering gear or control valve. This is done by the calibrated orifice or outlet in the output fitting of the new tool.

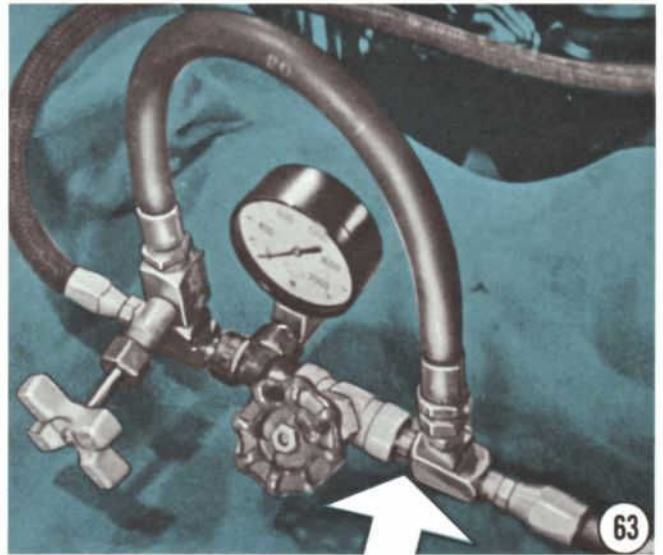

The new test setup directs fluid flow from the pump through the test tool and back into the pump. The other component parts in the system are bypassed.

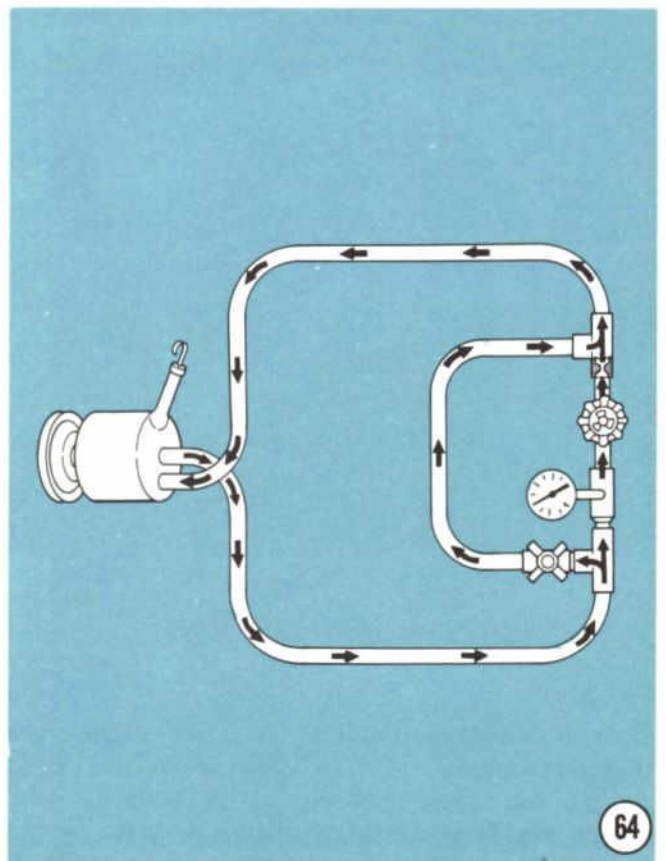

HOW TO CONDUCT A PUMP FLOW TEST

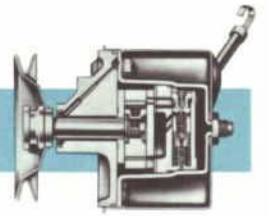

HOW TO CONDUCT A PUMP FLOW TEST

Assemble all the **added** test equipment to the original test equipment.

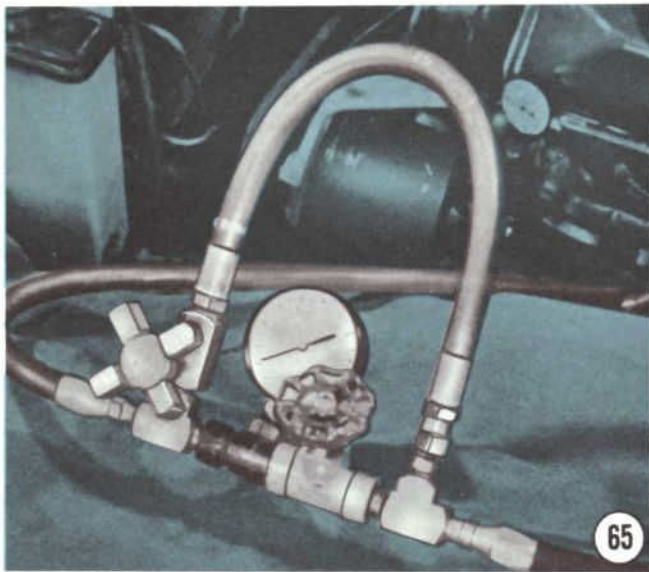

Disconnect the pressure hose from the pump. Then, disconnect the return line from the gear.

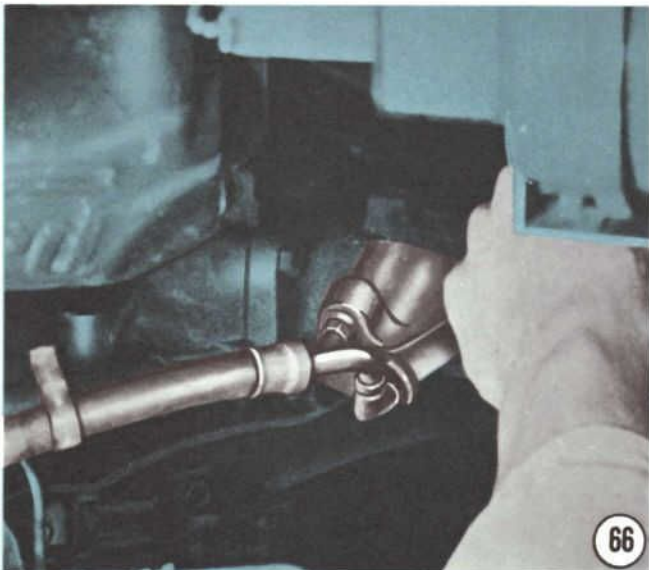

Connect the inlet hose of the test tool to the pump outlet.

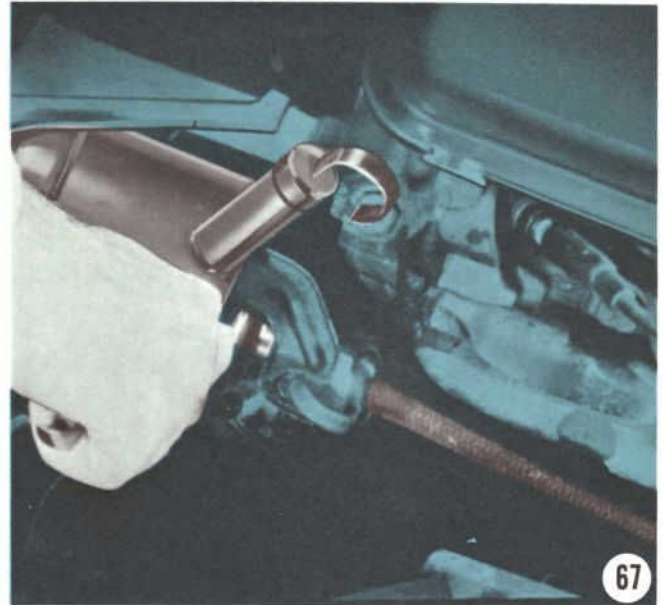

Next, connect the return hose from the gear to the return hose of the tool. On some cars, the steering gear is difficult to get at. In these cases, disconnect both hoses at the pump and use a return hose from out-of-stock instead of the return hose already installed in the vehicle.

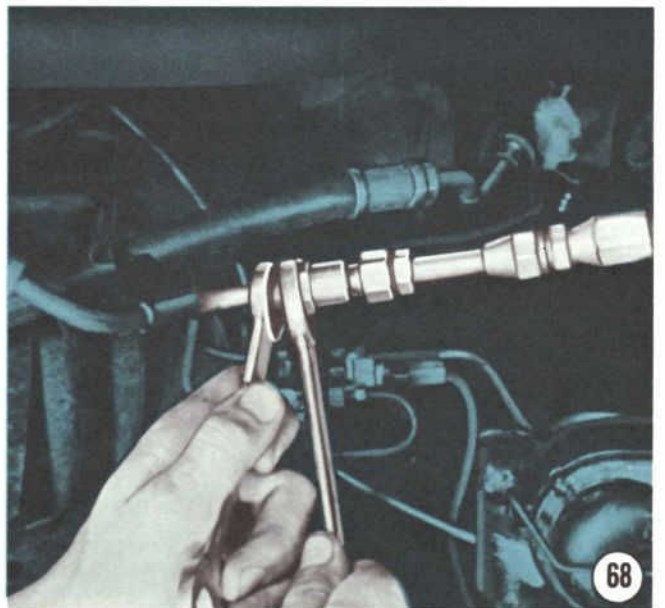

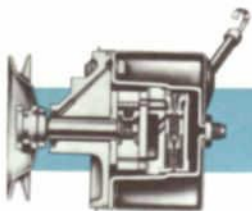

HOW TO CONDUCT A PUMP FLOW TEST

After the test tool is installed, **open** both manual valves to the **full-open** position.

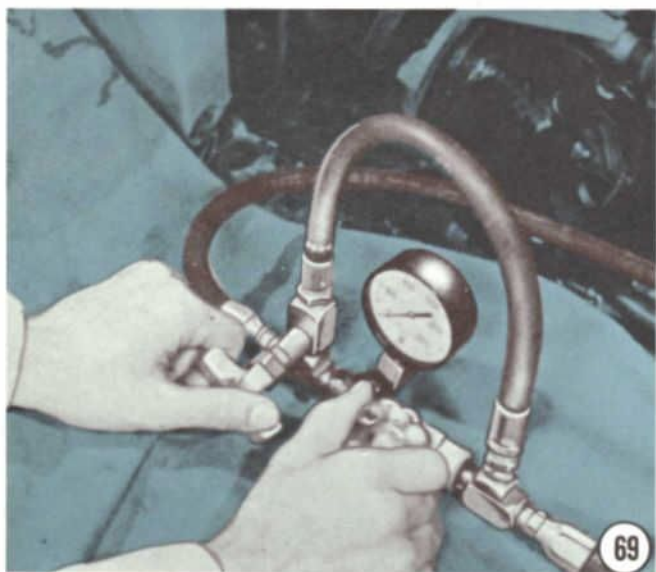

Remove the reservoir filler cap and dipstick assembly and insert the test thermometer in the filler neck.

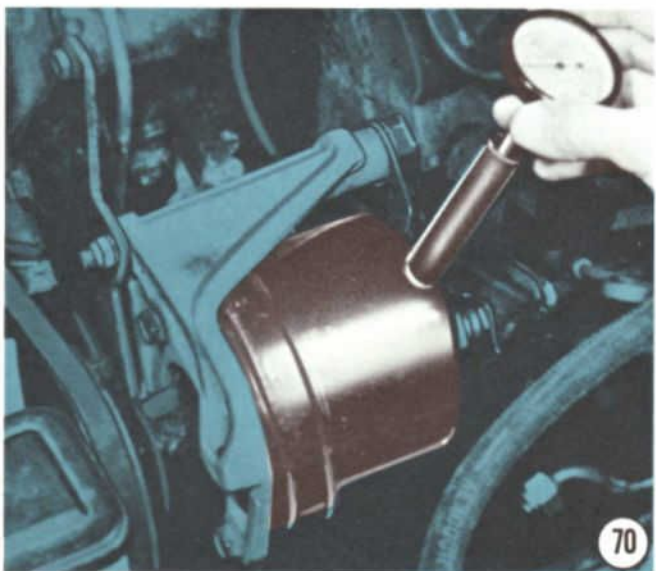

Install a tachometer and operate the engine at the idle speed specified in the applicable Shop Manual until the pump fluid temperature in the reservoir rises to within 165 to 175 degrees.

To assist temperature rise, partially close the manual valve in the bypass to create a back pressure. The back pressure must not exceed 350 PSI. When fluid temperature reaches a range of 165 to 175 degrees — with the engine still operating at the specified idle RPM — close the manual valve in the bypass.

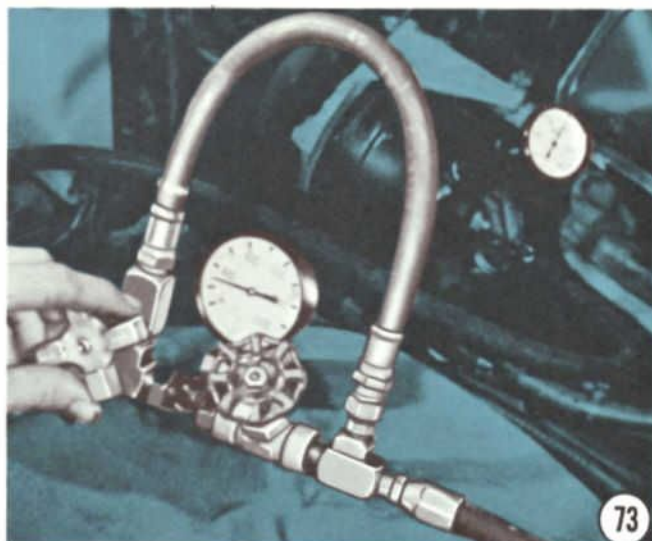

Check the gauge reading. The minimum acceptable pressure reading is 620 PSI. If the pressure reading is **below** the minimum of 620 PSI, the pump must be repaired. If the pressure reading is **at or above** 620 PSI, the pump flow is okay, and you can proceed with the pump pressure relief test.

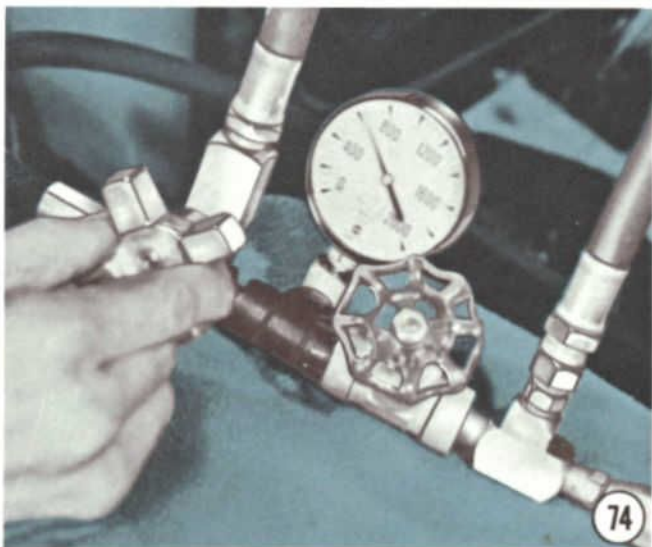

HOW TO CONDUCT A PUMP PRESSURE RELIEF TEST

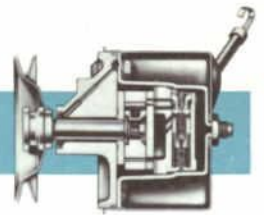

HOW TO CONDUCT A PUMP PRESSURE RELIEF TEST

Open both manual valves to the full-open position. Once again operate the engine at the specified idle speed until the pump fluid temperature in the reservoir rises to within a range of 165 to 175 degrees.

Close the manual valve at the gauge or output fitting.

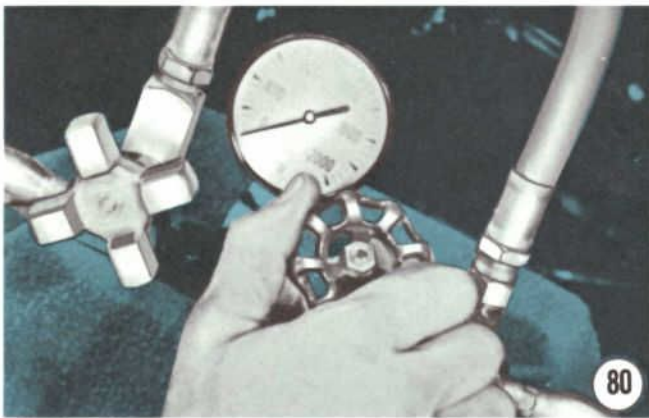

Next, close the manual valve in the bypass. **Do not keep both manual valves closed for more than 5 seconds at a time.** Longer periods will result in an abnormal increase of fluid temperature and cause excessive pump wear.



Now, check the pressure gauge reading and record it. Refer to the specifications in the Film Review (Ready Reference) book, applicable Shop Manual

or Specifications Booklet and compare the readings. If the pressure reading is **below** minimum specifications, the pump needs to be overhauled. If the pressure reading is **at or above** minimum specifications, the pump is okay. The problem may be in the power steering gear or the power assist control valve.

CAUSES OF LOW OUTLET PRESSURE

A **low** pressure valve installed in a pump requiring a **high** pressure valve will result in a **low** pressure output **below** specification.

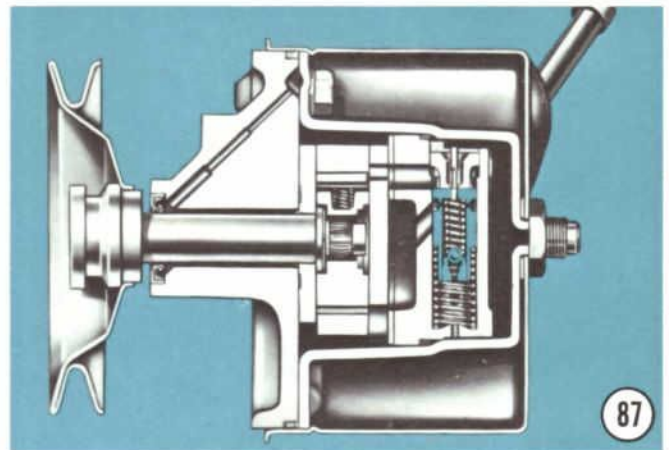

Low pressure output can also be caused by a relief valve ball sticking open or not seated within the valve cover. Other problem conditions can affect pump **flow**, as well as pump **pressure**.

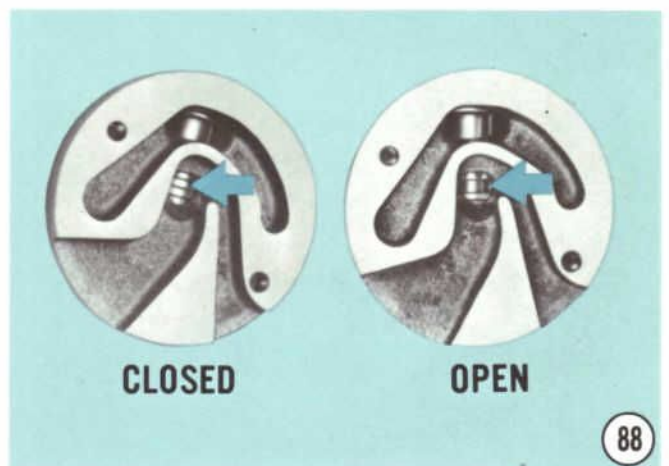

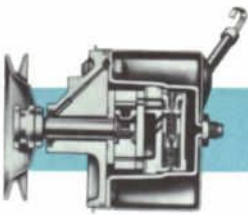

CAUSES OF LOW OUTLET PRESSURE

Two common sources of low pressure problems are an extremely low fluid level and a loose pump belt. These conditions should have been discovered and corrected during the preliminary checks.

Another condition which may cause low output pressure is a damaged ball or seat in the relief valve.

The same leakage condition, with resulting pressure drop, exists when the sealing surfaces are damaged at the valve cover or at the housing.

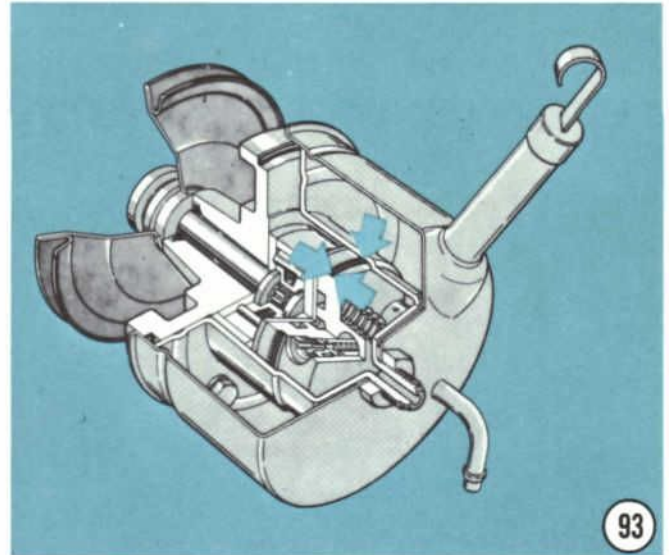
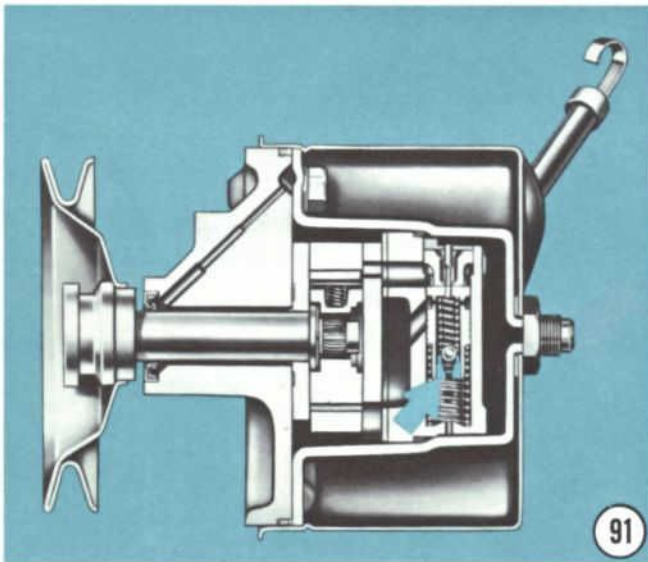

If the housing-to-valve and cover assembly seal is improperly assembled, damaged or omitted, oil will leak from the high pressure chamber into the inlet chamber. This will cause insufficient pressure.

Component parts, such as the housing plate, pressure plates, cam insert, retainer end plate, or valve and cover assembly will cause internal leakage and low pressure when they're not flat against the mating surface or the mating surfaces are damaged.

An improperly ground pump housing flange, for instance, provides leak channels on the low side to

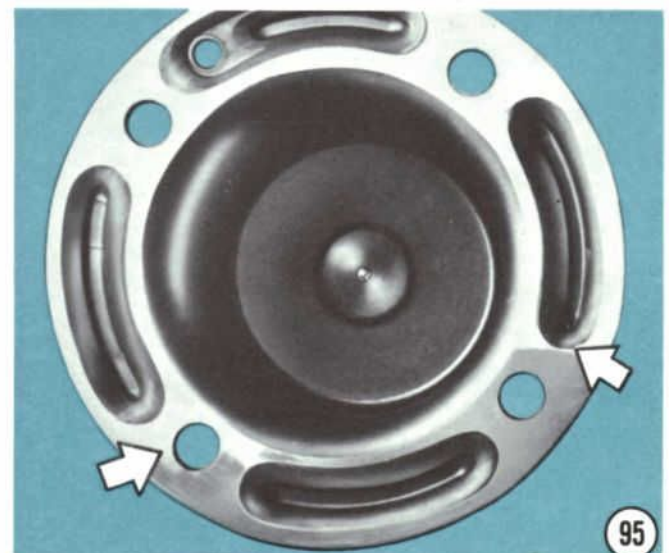
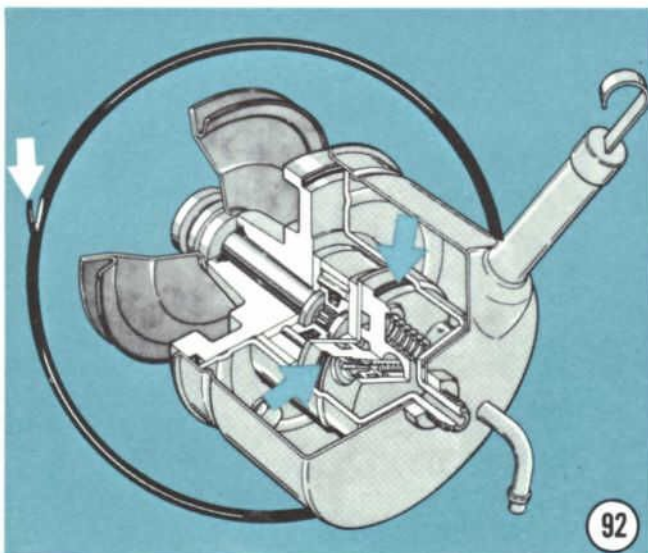

CAUSES OF LOW OUTLET PRESSURE

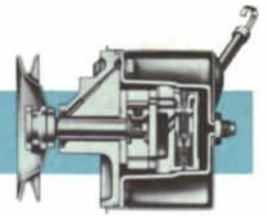

cause aeration, noise, and low pressure with fluid being discharged from the fill tube as system temperature increases. Also, as the temperature increases, so does the noise.

An improperly ground flange is also indicated by an improper seal area on the gasket surface, causing a leak path.

Improper assembly of internal parts, or missing parts such as pressure plate springs, will result in low pressure output.

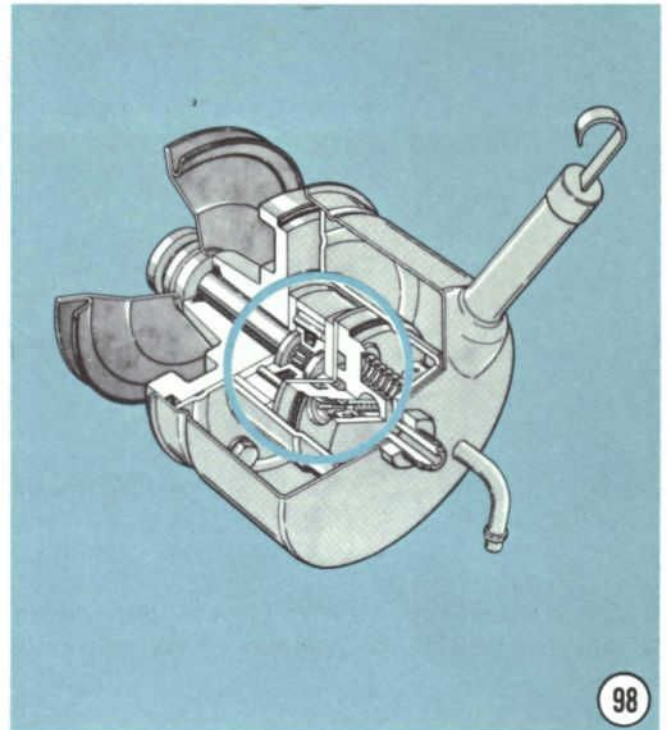
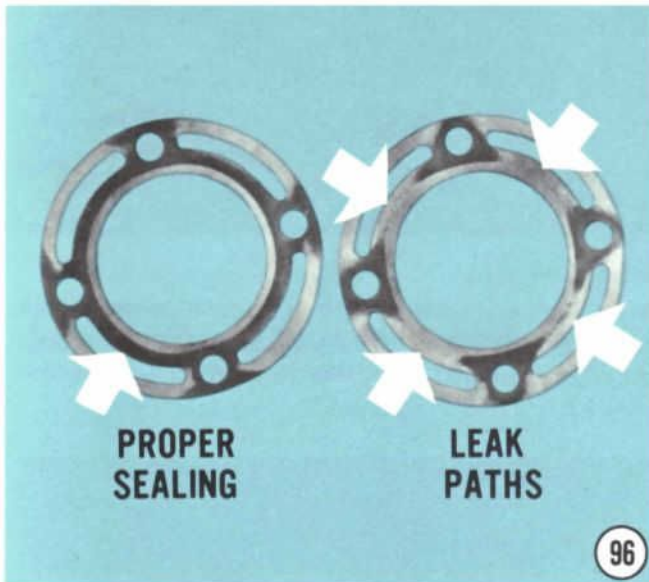

An improperly ground or out-of-flat pump valve assembly contributes to low pressure.

A plugged sensing orifice in the valve housing can cause a considerable pressure drop.

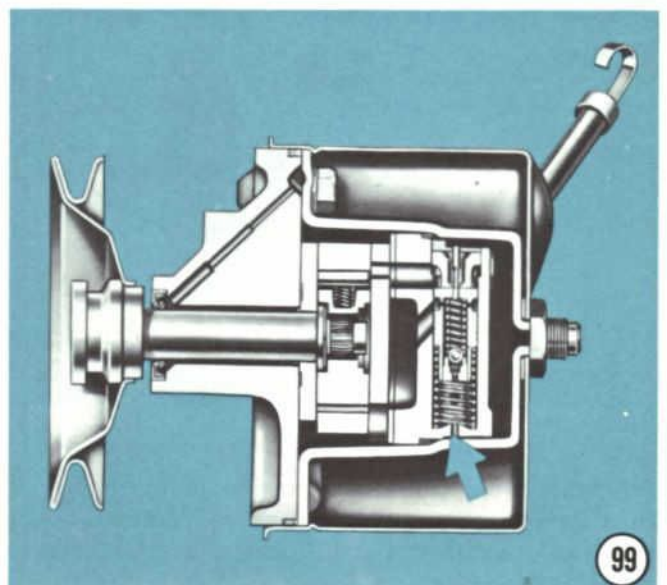
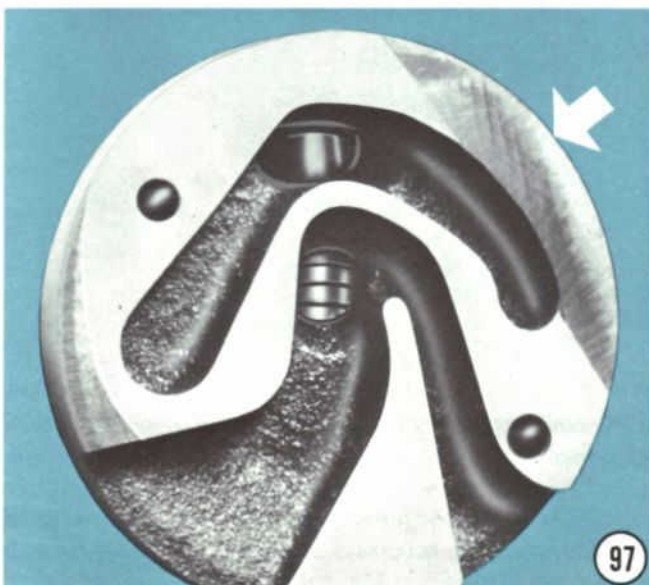

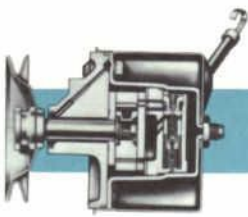

CAUSES OF LOW OUTLET PRESSURE

A plugged outlet orifice will cause the same condition.

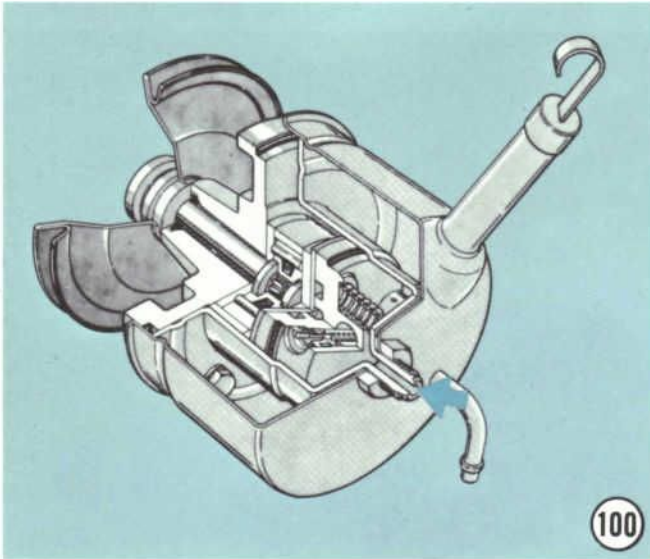

Interference between the outside diameter of the rotor and the cam surface will cause a clicking noise, improper assist and low system pressure.

Scored components, such as pressure plates, rotor or cam, can result in flow and pressure below specification.

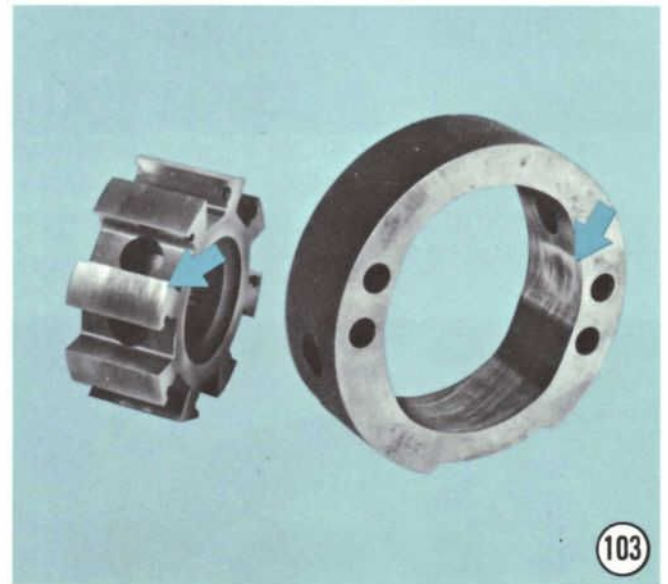
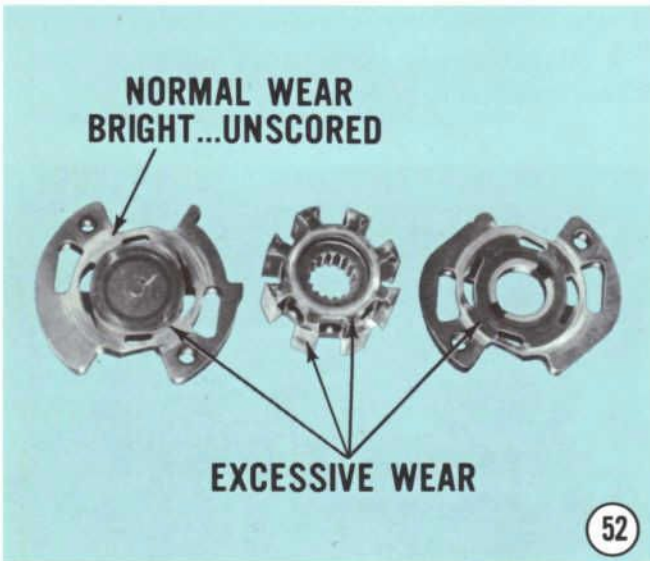

An out-of-flat condition of the upper or lower pressure plates will allow a leak path. This can cause low flow and high steering effort due to pressure below specifications.

If a pump is repaired due to wear, broken parts or dirt, it will be necessary to flush the steering system as outlined in the Shop Manual.

SPECIFICATIONS

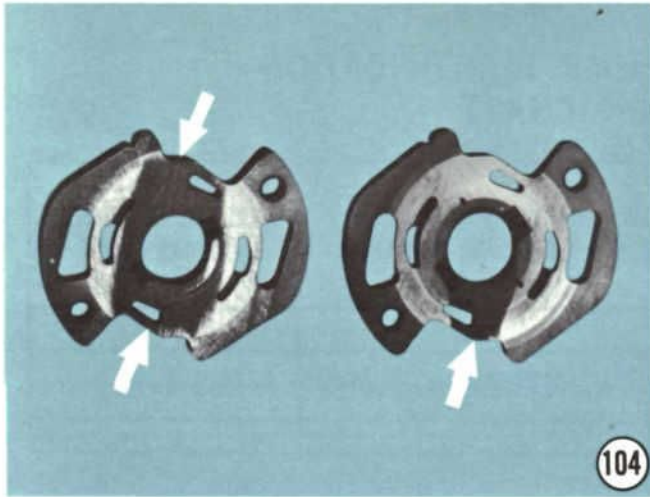
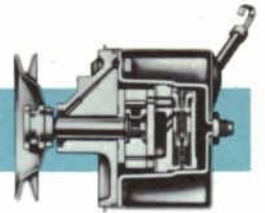

Upon completion of repairs and flushing procedures, make sure the pump reservoir is filled with fluid before attempting to operate the engine. Check the fluid level as outlined in the Shop Manual.

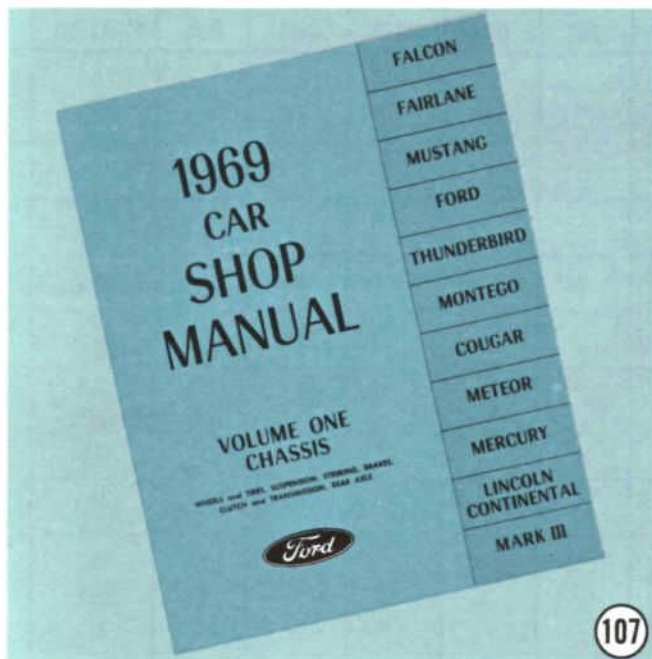

The diagnosis, testing and inspection procedures in this handbook and the repair or replacement procedures in your applicable Shop Manuals will enable you to correct any power steering pump problem that comes to your attention — and get a hearty “Well Done!” from your Ford service customers.

SPECIFICATIONS

The specifications were in effect at the time this information was approved for printing. Ford Motor Company reserves the right to change specifications and maintenance operations without notice and without incurring obligation. Refer to the applicable Shop Manuals and Technical Service Bulletins for the latest information and changes in specifications or maintenance operations.

FORD-DESIGN POWER STEERING PUMP IDENTIFICATION TAG

The Ford-design power steering pumps have an identification tag to identify assemblies for service purposes. The tag is located on the outlet fitting and fastened by a reservoir retaining nut.

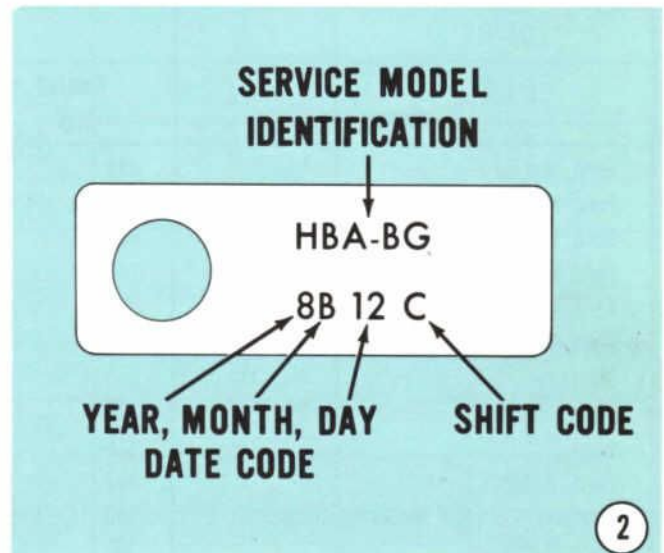

POWER STEERING PUMP SERVICE SPECIFICATIONS

Description	Ford
Pump Rotor Shaft End Play	.017 in. Max.— .003 in. Min.
Max. Torque Allowed to Rotate Rotor Shaft	15 In-Lb.
Stamped Housing to Plate Assy Screw and Washer Assy	28-32 Ft-Lb.
Reservoir to Stamped Housing Nut	43-47 Ft-Lb.
Cam Ring to Pressure Plate Screw	—
Housing to Cover Screw	—

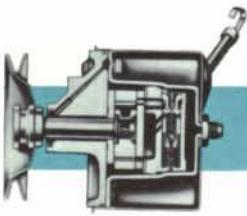

SPECIFICATIONS

FORD POWER STEERING PUMP IDENTIFICATION AND APPLICATION CHART

MODEL NUMBER	FALCON, MONTEGO FAIRLANE, MUSTANG, COUGAR (Except 302, 351 Engines)	FORD, MERCURY, METEOR, THUNDERBIRD WITH XR-50 STEERING GEAR	FORD WITH SAGINAW STEERING GEAR AND TRUCK F-100, F-250 (4 x 2)	FALCON, MONTEGO FAIRLANE, MUSTANG, COUGAR WITH 302, 351 Engines
HBA-BF	X			
HBA-BG		X		
HBA-BH			X	
HBA-BK				X

SERVICE IDENTIFICATION MODEL CHART — POWER STEERING PUMP PULLEYS

VEHICLE	ENGINE SIZE	AIR CONDITIONING			DUAL BELT ALTERNATOR			IDENTI- FICATION
		WITH	WITH- OUT	WITH OR WITH- OUT	WITH	WITH- OUT	WITH OR WITH- OUT	
Ford, Mercury	428	X				X		7AA
Ford, Mercury, Meteor	390	X				X		7AA
Ford, Mercury, Meteor, Thunderbird	429			X			X	8SA
Ford, Meteor	240		X		X			AD
Ford, Meteor	302		X		X			6AA
Ford, Meteor	390		X			X		6AA
Mercury	390, 428		X			X		6AA
Thunderbird	390	X				X		AF
Ford	428		X			X		6AA
Ford, Meteor	302	X				X		7AD
Fairlane, Montego, Mustang, Cougar	390, 427, 428		X			X		80B
Ford, Meteor	302		X			X		7AE
Fairlane, Falcon, Montego, Mustang, Cougar	302, 351		X		X			80B
Falcon	170, 200			X			X	80A
Mustang	200			X			X	80A
Fairlane, Montego, Mustang	250			X			X	90A
Fairlane, Montego, Mustang, Cougar	390, 428	X				X		AF
Fairlane, Montego, Mustang, Cougar	302, 351	X				X		7AD
Fairlane, Montego, Mustang, Cougar	302, 351		X			X		7AE
Truck F-100, F-250, F-350 (4 x 2)	240, 300			X	X			AD
Truck F-100, F-250, F-350 (4 x 2)	240, 300			X		X		AH
Truck F-100, F-250, F-350 (4 x 2)	360, 390	X				X		7AA
Truck F-100, F-250, F-350 (4 x 2)	360, 390		X			X		6AA

SPECIFICATIONS

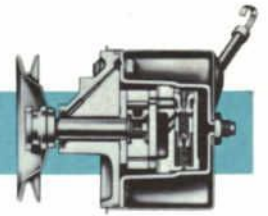

FORD POWER STEERING PUMP TORQUE LIMITS (FT-LBS)

Description		Ford, Mercury, Meteor, Thunderbird	Cougar, Falcon, Fairlane, Montego, Mustang
Pump Rotor Mounting Nut		14-18	20-30
Pressure Hose Nut		20-30	20-30
Pump Attaching Nuts		25-35	30-40
Bracket to Engine Attaching Nuts	6-Cyl.	12-16	7-10
	302-351 CID	18-25	18-25
	390, 428, 429 CID	30-40	30-40
Bracket to Cylinder Head		25-35	25-35
Belt Adjustment Bolt		—	25-35
Rear Support Bracket Attaching Nuts	240 CID	45-60	—
Bracket to Engine Adapter	170-200 CID	—	25-35
Engine Adapter to Engine	170-200 CID	—	17-25
	250 CID	—	30-40
Engine Adapter to Pump	250 CID	—	25-35

