

tech talk

VOL. 2, NO. 1

SEPTEMBER, 1969

Autolite

1970 Announcement Issue

- Autolite Part Numbers
- Maintenance Schedules
- Specifications
- Service Procedures
- Model Identification
- New Features

Grandé





FORD XL



MERCURY



FORD TORINO



THUNDERBIRD



COUGAR



CONTINENTAL MARK III



FALCON

1970



MONTEGO



MAVERICK



MUSTANG

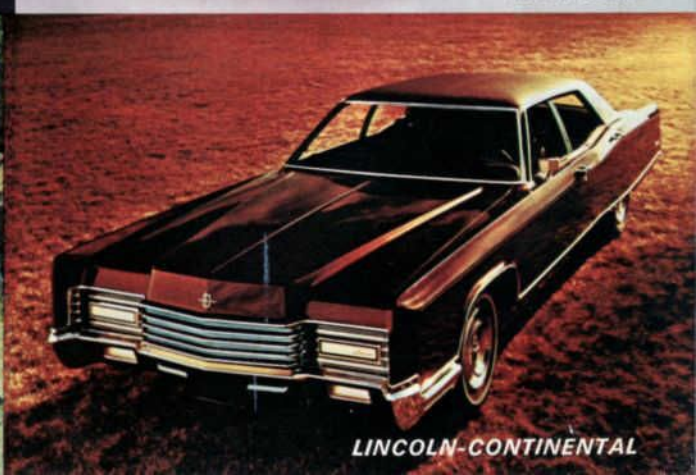

LINCOLN-CONTINENTAL

IN THIS ISSUE

MUSCLE Is The Message . . . Performance Heads List of 1970 Features 2-3

Performance Equipment	2
Performance Engines	3

NEW FEATURES FOR 1970 4-6

351 Engine	4
Four Sixes for 1970	4
Water Pump	4
Engine Accessory Drive	4
Externally Adjustable Headlamps	5
Tamper Resistant Odometer	5
Freon-Filled Shocks	5
Concealed Wipers	5
Tires	5
Automatic Seat Back Release— 2-Door Models	6
New Ventilation Systems	6

1970 SAFETY AND SECURITY FEATURES 7

Three-Point Lap and Shoulder Belt "Uni-Lock Safety Harness"	7
Front and Rear Side Marker Lamps	7
Three-Way Locking Steering Column	7

EMISSION CONTROL SYSTEMS FOR 1970 8-9

Fuel Evaporative Emission Control System	8
Close Crankcase Ventilation System	8
Improved Combustion IMCO System	8
Thermactor System	9

1970 SERVICE TIPS 9

Two Spark Plug Sizes Used in 1970 Engines	9
---	---

Carburetor Throttle Solenoid Modulators	9
---	---

1970 MAINTENANCE SCHEDULES 10

Ford, Torino, Mustang, Maverick, Falcon & Thunderbird	
---	--

1970 MAINTENANCE SCHEDULES 11

Cougar, Montego, Mercury, Mark III & Lincoln Continental	
--	--

1970 MODELS AND SPECIFICATIONS 12-41

Cougar	12-13
Montego	14-15
Mercury	16-17
Continental Mark III	18-19
Lincoln Continental	20-21
Ford	22-23
Torino	24-25
Mustang	26-27
Maverick	28-29
Falcon	30-31
Thunderbird	32-33
Bronco	34
Econoline	35
Ford Trucks (Series 100 thru 350 and P)	36-37
Ford Trucks (Series F and B 500 thru 750, C & W)	38-39

AUTOLITE PART NUMBER APPLICATION CHART FOR 1970 MODELS 40-43

AUTOLITE ORIGINAL EQUIPMENT PARTS 44

Be sure and file this and future bulletins for ready reference. If you have any suggestions for additional information that you would like to see included in this publication, please write to: Autolite-Ford Parts Division of Ford Motor Company, Merchandising Services Dept., P.O. Box 3000, Livonia, Michigan 48151.

The description and specifications contained in this book were in effect at the time the publication was approved for printing. The Ford Motor Company, whose policy is one of continuous improvement, reserves the right to discontinue models at any time, or to change specifications or design without notice and without incurring obligation.



MUSCLE IS THE MESSAGE...

PERFORMANCE EQUIPMENT

The big news for 1970 is a number of new items for the performance, or muscle car market. Sports orientated buyers can order all new performance-styled machines like the Mustang Mach I, Cougar Eliminator, Torino Cobra and Cyclone Spoiler with a variety of components such as:

- Competition suspension with staggered shocks
- Traction Lok variable friction-load "locking" axle
- Detroit Locker "No Spin" axle for all-out competition
- Hurst four-speed shifter with competition "T" handle
- Front and rear air spoilers
- Quick ratio manual steering gear
- "Shaker" and/or Ram Air hood scoops
- Sports slats (Mustang and Torino Sports Roof only)
- Engine oil cooler
- Four different performance engines

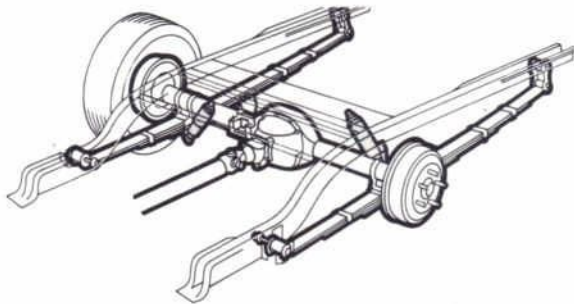

Staggered Shocks

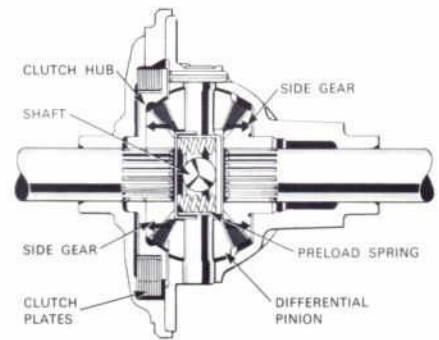

Traction Lok



Hurst Shifter



Detroit Locker

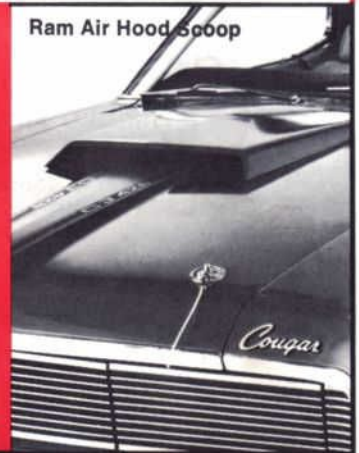

Ram Air Hood Scoop

Spoiler & Sports Slats



Boss 302

Performance Heads List of 1970 Features

PERFORMANCE ENGINES

Four engine series power Ford's "hot ones" for 1970; the 428 Cobra Jet, a carryover from 1969, the Boss 302 and 429 which were introduced as limited production options during the 1969 model run, and an all new 351.

Boss 302 Engine

The Boss 302 is available only on Cougar Eliminator and Boss 302 Mustangs. It's an HO (high output) version of the standard 302 engine and puts out 290 horsepower at 5800 rpm. In addition to its high power to size ratio, this engine features extreme ruggedness and durability even for all-out competition. Special design features include:

- Large, round ports and "canted" valves for free-breathing heads
- Forged crankshaft with cross-drilled main journals and 4-bolt main bearing caps at No. 2, 3, 4 journals
- Heavy duty connecting rods with $\frac{3}{8}$ " diameter cap bolts
- Large 2.18" intake and 1.71" exhaust valve head diameters
- Solid lifter camshaft with 0.500" lift
- Dual breaker point distributor with dual diaphragm advance

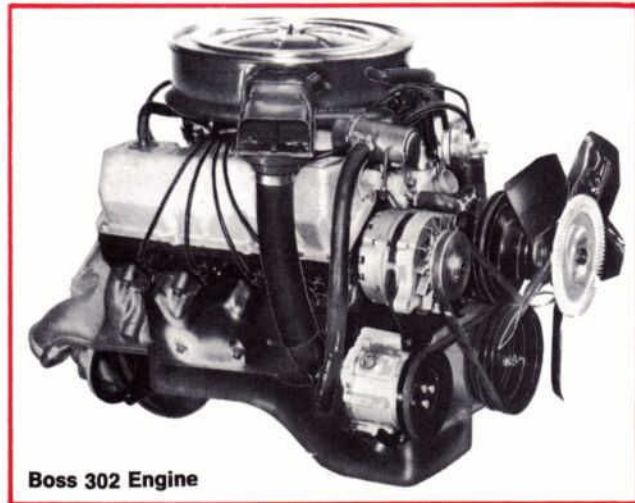

Boss 302 Engine

429 Engines

Five versions of the 429 are used in Ford Motor Company cars in 1970; the 429-2V, 429-4V, 429-4V Cobra, 429-4V Cobra Jet ("Ram Air") and 429-4V Boss. The latter three are high performance engines. The 429 Cobra and Cobra Jet engines are similar, except that the Cobra Jet is equipped with a ram air hood scoop. They feature:

- High strength, cast nodular-iron crankshaft
- High strength connecting rods and rod bolts
- Dual entry front and rear oil pump sump
- Large runner, high-rise cast-iron intake manifold
- Big valves and large cylinder head chamber
- Header type, low back pressure exhaust manifolds
- High lift camshaft and 700 cfm 4V carburetor
- Mechanical lifters and 780 cfm 4V carburetor on 429 Super Cobra Jet

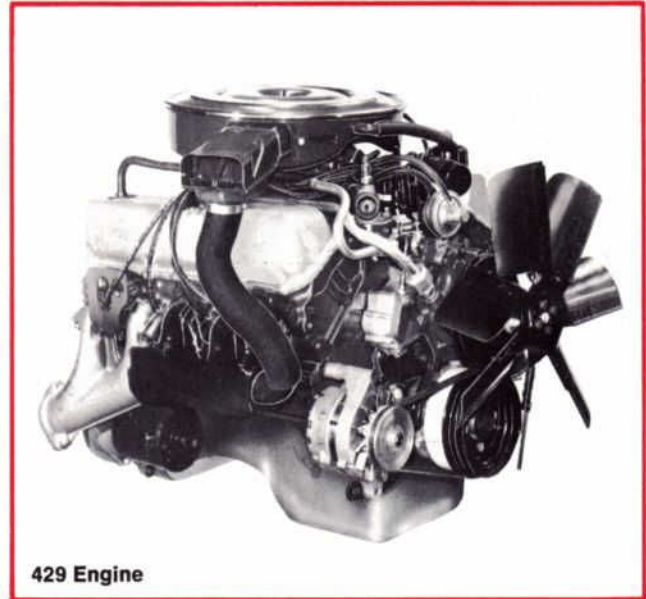

429 Engine

429 Boss

The 429-4V Boss engine was introduced in mid-1969 in limited quantities. Basically it's a street version of the highly successful engine used in many Ford and Mercury NASCAR victories. It has many design features that provide exceptional performance and durability. It's immediately recognizable by large, cast-magnesium rocker arm covers with deep indentations that allow placement of the spark plugs almost centrally over the bore.

The cast-aluminum cylinder heads feature a semihemispherical combustion chamber design. This allows the valves to be "canted" transversely in a true crossflow configuration in the direction of gas flow for maximum breathing. Large round ports and oval exhausts are used in place of the conventional rectangular ports, for improved breathing. Valve guides and seats are pressed into the aluminum heads. Instead of a cylinder head gasket, rubber washers are used to seal the water and oil passages between the head and block, and metal "O" rings seal the cylinder bores.

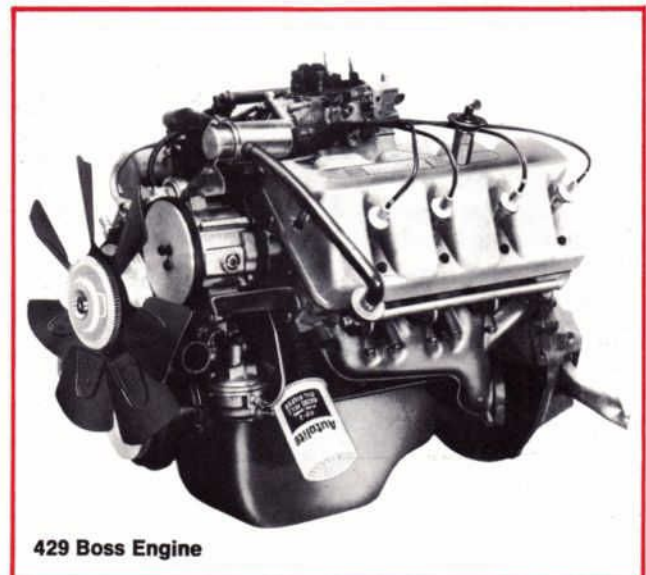

429 Boss Engine

MORE NEW FEATURES FOR 1970

351 ENGINE

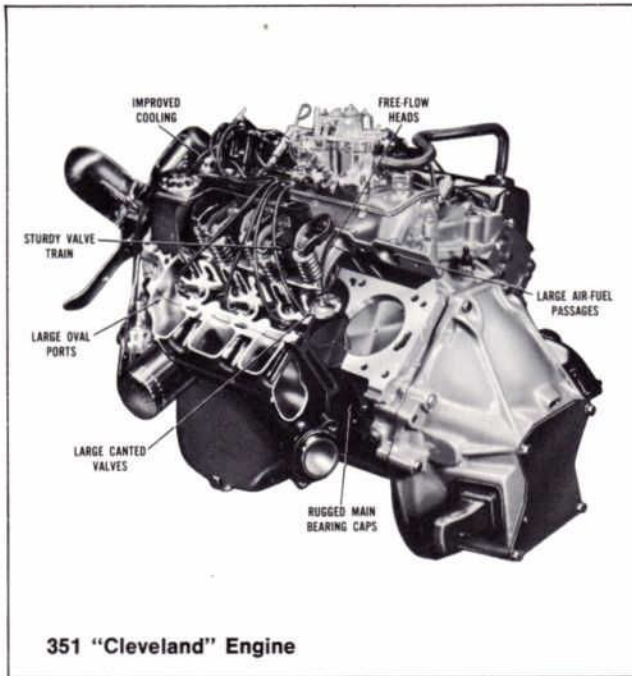

351 "Cleveland" Engine

The 351 is a completely new engine for 1970 and comes in 2V and 4V versions. Commonly called the "Cleveland" 351 (because it's built there) it resembles last year's so-called 351 "Windsor" engine only in cubic inch displacement. The new 351 incorporates several features for added performance and durability that have proven highly successful on the larger 429 racing engine.

- **Cylinder Block** – All new design features an integral timing chain chamber/water crossover passage. The water crossover passage is located in the upper front of the cylinder block, instead of in the intake manifold, and has a heater supply outlet fitting, temperature sending unit and water by-pass opening.
- **Cylinder Heads** – All new heads feature large, round ports and canted valves for more efficient breathing and maximum flow capacity.
- **Intake Manifold**—All new design with water crossover at front eliminated to permit high performance runner configuration. A new, unique one-piece steel intake manifold gasket is used to retain oil in the tappet chambers away from the hot exhaust crossover passage. Two identical end seals are used. They are held in position by tabs that fit into machined holes in the block.
- **Exhaust Manifold** – Large header type for minimum back pressure.
- **Valve Train**—High lift, solid lifter camshaft has a larger No. 1 bearing for extra durability. The rocker arms and fulcrums are wider and more stable. Stiffer valve springs are used with an inner damper spring.
- **Valves**—Feature a flat head design with 2.19" diameter on intakes and 1.71" on exhausts.
- **Valve Rocker Arm Covers**—Both covers have a bayonet-lock oil filler cap and oil drip fingers inside covers for improved rocker arm lubrication.

FOUR SIXES FOR 1970

Four 6-cylinder engines are available in 1970: the 170, 200, 240 and 250. Essentially they are carryover from 1969. However, there are a couple of important changes.

- **New Cylinder Head on 170 and 200** – Both of these engines use the larger 250 cylinder head and larger valves for improved fuel economy and performance. All 170, 200 and 250 CID engines now use the same head except for minor differences in combustion chamber design to maintain the proper compression ratio for each engine size.
- **New Carburetors** – 6-cylinder engines feature a new carburetor for 1970 with more precise fuel metering and throttle control during acceleration to further reduce exhaust emission over previous designs.

WATER PUMP

All 1970 six and eight cylinder engines use a new water pump that incorporates such improvements as double-row, 3/4-inch I.D. ball bearings (largest in the industry) . . . a ceramic-faced impeller seal for greater durability . . . an improved high temperature nitrile seal-face and boot material . . . a stainless steel spring . . . and new manufacturing techniques for greater reliability.

ENGINE ACCESSORY DRIVE

302 and 351 engines with power steering or air conditioning, and all 429 and 460 engines have a new front-end accessory drive that uses separate belts to drive the water pump and alternator . . . instead of driving both from the same belt as in the past. This not only permits more positive drive of the alternator, but less tension is required on the water pump belt, thereby reducing the load on the water pump bearings.

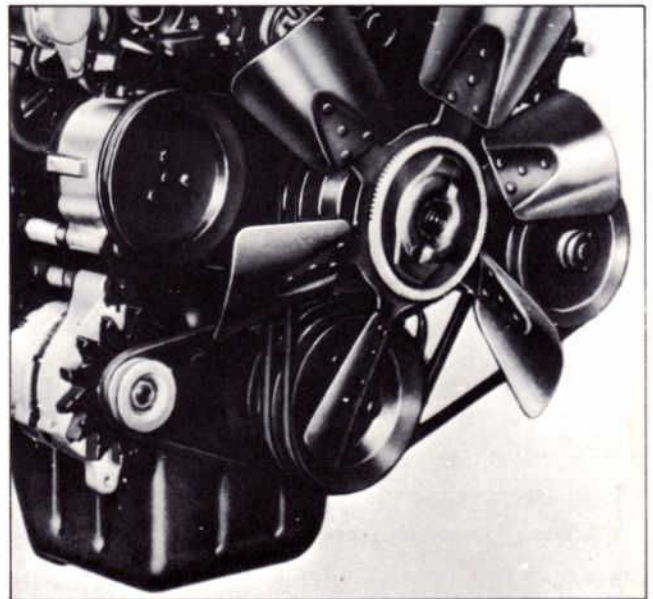

This new drive arrangement allows an increased 3:1 alternator drive ratio, resulting in higher electrical output at lower rpm. This provides more dependable air-conditioner and other electrical equipment operation in stop-and-go traffic, or at idle.

EXTERNALLY ADJUSTABLE HEADLAMPS

Ford, Torino, Mustang, Maverick, Thunderbird, Cougar and Mark III models feature externally adjustable headlamps, for both concealed and exposed type headlights. It is not necessary to remove bezels or frames to adjust these lights. Access holes are provided through which a screwdriver can be inserted and the screws turned in or out to quickly obtain the desired adjustment.

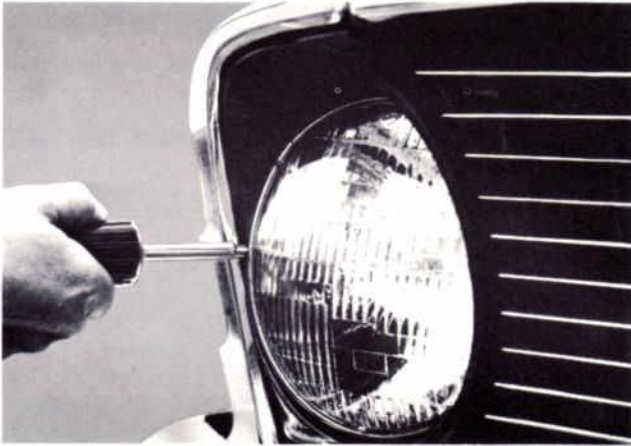

TAMPER RESISTANT ODOMETER

This new device makes it difficult to tamper with odometer readings on 1970 models. A one-way clutch in the speedometer head doesn't permit the mileage indicator gear to be turned in reverse.

FREON-FILLED SHOCKS

1970 Mercury and Lincoln-Continental models use shock absorbers with a special type of plastic bag filled with inert freon gas submerged in the hydraulic fluid reservoir. It takes the place of the air space in conventional shock absorbers and has two major advantages:

- The freon filled bag prevents air from mixing with hydraulic fluid under severe road conditions, thereby helping to reduce "frothing" that reduces shock absorber control
- The freon gas has the ability to absorb more heat, thus helping to maintain more constant fluid viscosity for better ride control

CONCEALED WIPERS

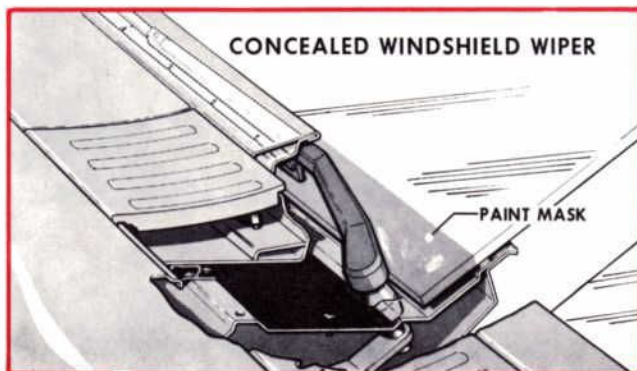

Concealed wipers are used on 1970 Torino, Thunderbird, Mark III and Montego models. The windshield glass extends below the sight line and the wiper blades are stored at the base of the glass.

TIRES

Fiberglass Bias-Belted Tires

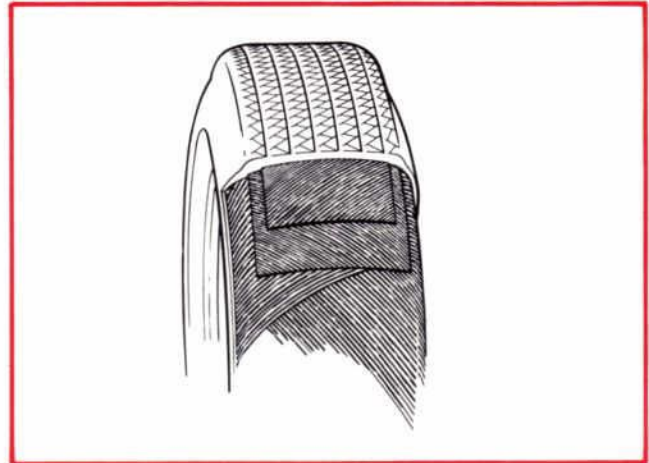

Optional on most lines last year, fiberglass bias-belted tires are now standard on 1970 Ford, Torino, Mustang, Cougar, Montego, Mercury and Lincoln Continental models. They come in four basic sizes and three aspect ratios (tire width vs. tire height) .78, .70, and .60 depending on model, engine and options. Construction consists of two polyester bias plies and two fiberglass belts (a total of 4 plies). These tires provide increased mileage, better puncture resistance and improved directional stability and stopping ability. Most of these feature improvements are attributable to the two fiberglass belts under the tread, which reduce tire deformation and rolling resistance for less scuffing and better contact with the road.

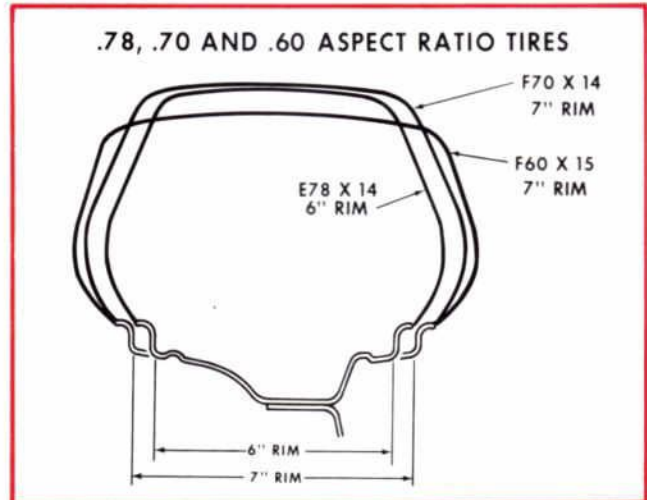

Radial Ply Tires

Radial ply tires, size 215R15 are standard equipment on 1970 Thunderbirds. Michelin 225-15 steel-belted radial ply tires are standard on Continental Mark III models. Radials get their name from the layers of cord (plies) that run at right angles to the tire centerline from rim bead-to-rim bead.

Over these plies, and under the tread, layers of belting run around the tire. This design gives radials greater sidewall flexibility, which tends to keep the tread flatter against the road. This reduces sway on turns and improves the overall handling characteristics of the car. The belts under the tread also help prevent tire deformation at higher speeds, thereby reducing tread scuffing and substantially increasing tire mileage.

STILL MORE 1970 FEATURES

OPTIONAL AUTOMATIC SEAT BACK RELEASE— 2-DOOR MODELS

This new convenience feature is standard on Mark III models and optional either separately or as a part of a group option on most other models. It eliminates the need to manually release the front seat backs when passengers enter or leave the rear seat. Both front seat back latches automatically release when either door is opened. A door jam switch, located in the "A" pillar, triggers the seat back latch release relay that supplies electrical current to a solenoid on each seat back. A manual release is also provided in the event of an electrical failure or other malfunction.

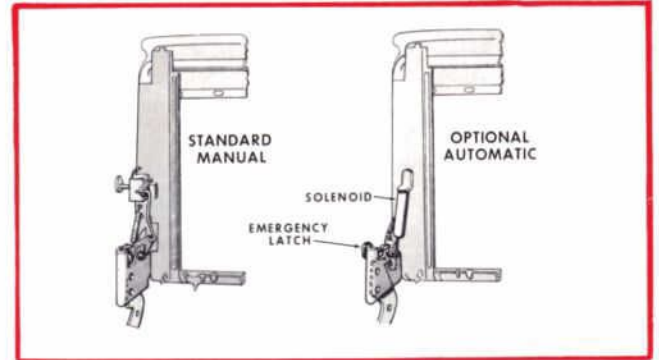

NEW VENTILATION SYSTEMS

Three ventilation systems are used on 1970 models. Thunderbird, Continental Mark III and Lincoln Continental cars offer a Flow-Thru fresh air system as standard equipment. Air enters through hidden vents under the hood and circulates into the passenger compartment from high and floor level outlets. Stale air and smoke exit through a vacuum controlled vent under the rear window that is opened or closed by a rocker switch on the instrument panel.

A similar Direct Aire high-low air outlet vent system in the front compartment (but with pressure relief valves in the door lock pillars) is standard on 1970 2-door Torino and Montego cars, and optional on other models. The standard system on 4-door models and all Ford, Mercury, Mustang and Cougar cars uses the conventional floor level fresh

air inlets and Flow-Thru pressure relief valve in the door lock pillars.

The high-low system features two fully adjustable barrel-type registers; one in each end of the instrument panel. Air flow is adjusted by moving the louvers right or left or by rotating the barrel up or down. Both it and the conventional system with only lower outlets utilize air outlet openings in front of the rear seat that allow air to flow into the luggage compartment . . . then back through inner body panels to the pressure relief valves in the door pillar panels. The one-way pressure relief valves prevent reverse air flow when the system is not in use, and also function when the heater or air conditioner is in use.

DIRECTAIRE FLOW-THRU VENTILATION

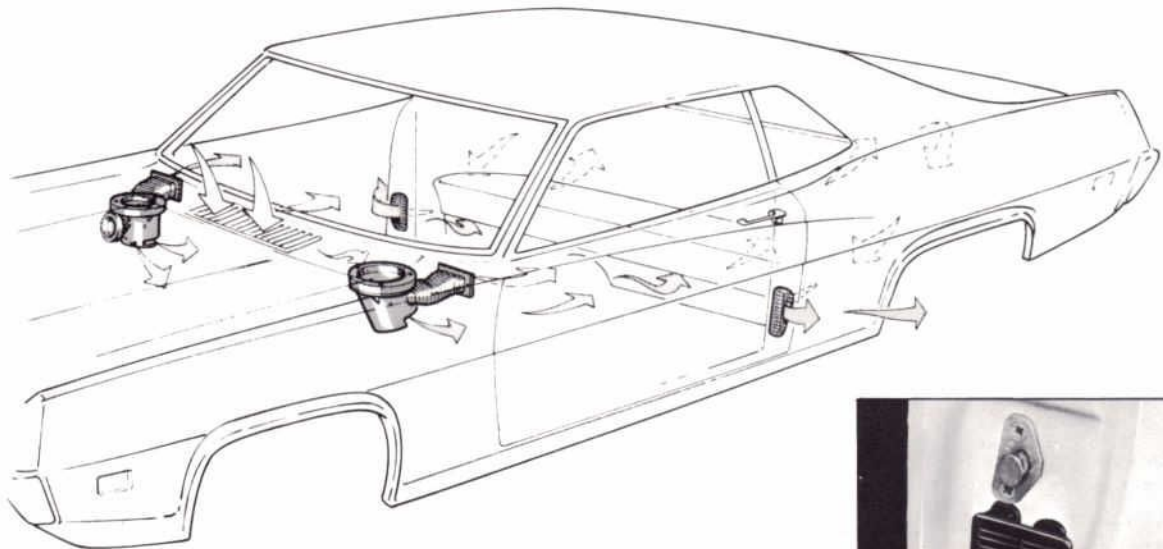

1970 SAFETY and SECURITY FEATURES

All Ford Motor Company vehicles will meet or exceed all Federal Safety and Security requirements. All new for 1970 are:

- Three point lap and shoulder belt "Uni-Lock Safety Harness" (Except Maverick, Falcon and all convertible models)
- Three way locking steering column*
- Improved side marker lamps*

*Excludes Falcon. To be installed on Maverick after October, 1969.

THREE-POINT LAP AND SHOULDER BELT "UNI-LOCK SAFETY HARNESS"

This unique, new restraint system permits front seat occupants to "buckle up" faster and more conveniently than previous belts. The separate buckle and inboard belt-half for the shoulder belt have been eliminated, along with the need to adjust lap belt length. During use, the driver or outboard front seat passenger pulls the belt out of the retractor and snaps it into the "mini" buckle that's nearly half its former size. The roll-up retractor maintains correct lap belt length. The shoulder belt is then attached to the lap belt and adjusted if necessary.



FRONT AND REAR SIDE MARKER LAMPS

The front and rear side marker lamps—amber in front and red in rear—have two important changes for 1970.

- Both front and rear side markers flash with the turn signals when the parking lights are "off", or alternating with the turn signals when the parking lights are "on", providing better visibility of the driver's intention to turn. They also flash with Emergency Flashers.
- Both front and rear markers have high level reflective "fresnel" lens, providing improved visibility when the vehicle is parked, or if a bulb burns out.

THREE-WAY LOCKING STEERING COLUMN

The three-way locking steering column is designed to deter car thefts by locking the ignition, the transmission linkage and the steering wheel with the ignition switch.

The newly designed ignition switch and concealed locking mechanism is mounted on the steering column, within convenient reach of the driver. The ignition switch has five positions: Accessory . . . Lock . . . Off . . . On and Start . . . in that sequence. When the engine is running, the switch will be in the On position. To stop the engine the switch is turned to the Off position. The key cannot be removed, however, unless the switch is turned to the "Lock" position. Before the switch can be turned to "Lock", the transmission lever on automatic transmission cars must be positioned in "Park" or on manual transmission cars in "Reverse".

The steering wheel is locked by a spring loaded pin that engages in a 12-hole locking plate. This permits locking every 30 degrees. The pin is actuated through a rack drive by a gear located on the end of the ignition lock cylinder.

The transmission lever on column mounted cars is locked by a rack passing into slots in the shift casting. On cars with floor or console mounted transmissions this function is performed by a rod connected between the transmission shifter and steering column.

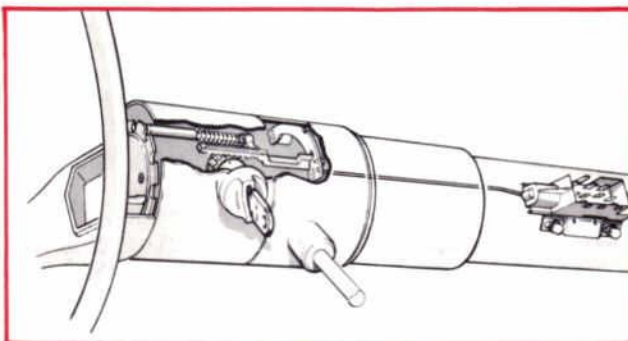

1970 STANDARD SAFETY AND SECURITY FEATURES

- Dual Hydraulic Brake System with Warning Light
- Glare Reduced Instrument Panel Padding, Windshield Wiper Arm, Steering Wheel Hub, Rear View Mirror and Windshield Pillars
- Energy-Absorbing Steering Column and Steering Wheel
- Energy-Absorbing Armrests and Safety-Designed Door Handles
- Three-Point Restraint System with Mini-Buckles and Roll-up Seat Belt Retractors (Lap belts only on convertibles—Separate lap and shoulder belts on Falcon and Maverick)
- Turn Indicators with Lane Changing Signal Feature
- Inside Day/Night, Yield-Away, Rear View Mirror (Day/Night feature not available on Maverick)
- Energy-Absorbing Instrument Panel with Padding
- Padded Safety Sun Visors
- Two-Speed Windshield Wipers
- Windshield Washers
- Laminated Safety Glass Windshield
- Double Yoke Safety Door Latches and Safety Hinges
- Positive Door Lock Buttons
- Eight-Way Hazard Flasher (except Falcon)
- Back-Up Lights
- Side Marker Lights with Reflective Lens
- Energy-Absorbing Front Seat Backs with Padding
- Self Locking Folding Front Seat (Two-Door Models) or Rear Seat (Wagons)
- Vehicle Structure Designed to Limit Steering Column Displacement
- Safety Designed Window Regulator Knobs
- Safety Designed Coat Hooks
- Safety Designed Radio Control Knobs
- Outside Rear View Mirror, Driver's Side
- Safety Rim Wheels and Load-Rated Tires
- Corrosion-Resistant Brake Lines
- Uniform Transmission Shift Quadrant (P R N D 2 1)
- Head Restraints—Adjustable or High-Back Bucket Seats (Not available on Falcon or Maverick)
- Locking Steering Column*
- Front & Rear Marker Lights Flash Off and On in Conjunction with Turn Signals*
- Parking Lights Coupled with Headlights
- Safety Glove Box Latch

*Excludes Falcon. To be installed as a running change on Mavericks produced after October 1, 1969.

EMISSION CONTROL SYSTEMS

FUEL EVAPORATIVE EMISSION CONTROL SYSTEM

All 1970 Ford Motor Company vehicles sold in California will include a fuel evaporative emission control system. Similar systems are expected to be mandatory nationwide in the near future. Basically, this system prevents escape to the atmosphere of fuel vapors from the carburetor and gas tank.

The system consists of separate elements for collection, separation and storage of the vapors.

The fuel tank has a non-vented cap and the carburetor has a new internal vent.

The fuel tank is revised to provide for vapor collection in the top and to limit the fill to prevent spill-over during a hot soak period. A separate tank is located above the fuel tank to separate vapor and liquid.

Liquid is returned to the fuel tank and fuel vapor is transported either to a carbon canister in the engine compartment, or the engine crankcase, depending on the engine application.

The carbon canister absorbs and stores the fuel vapor when the engine is not running. The vapors are extracted by drawing heated fresh air through the carbon canister when the engine is running. The heated air and vapors flow through a line connected to the air cleaner where they are drawn into the engine and burned.

On installations where the fuel vapors are stored in the engine crankcase, the vapors are extracted through the crankcase emission system PCV valve and burned in the engine.

A combination valve located on the forward side of the fuel tank isolates the fuel tank from engine-induced pressures and allows vapor to escape from the vapor separator tank to the carbon canister.

It also functions to relieve excessive fuel tank pressure to the atmosphere in the event of blockage in the vapor delivery line, and allows fresh air to be drawn into the fuel tank to replace fuel as it is used.

1970 EVAPORATIVE EMISSION CONTROL SYSTEM - CARBON STORAGE

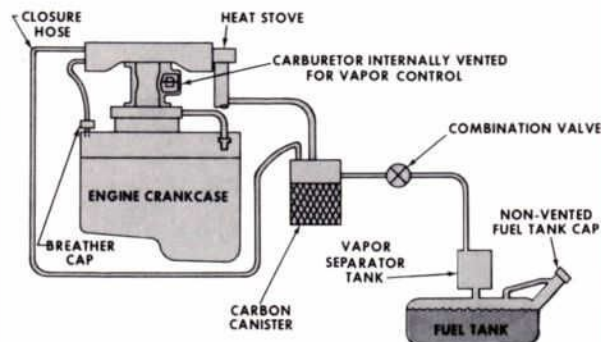

1970 EVAPORATIVE EMISSION CONTROL SYSTEM - CRANKCASE STORAGE

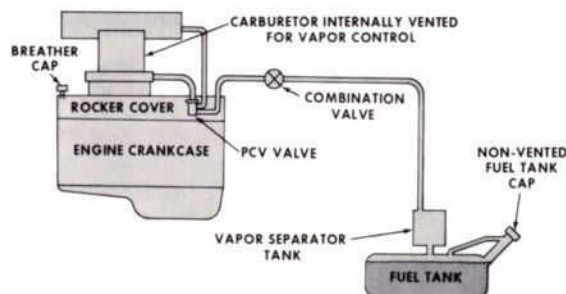

CLOSED CRANKCASE VENTILATION SYSTEM

The closed crankcase ventilation system is used on all 1970 Ford engines to prevent the escape of fumes and/or combustion gases from the engine crankcase. This system involves several distinct steps.

- Clean air circulates from the air cleaner through the block to the crankcase.
- Circulating air picks up smog-producing vapors en route.
- Air and crankcase vapors pass through a control valve and hose to the intake manifold.
- Gases combine with the air-fuel mixture and are re-burned in the combustion chamber.
- A control valve modulates the system airflow to maintain the correct air-fuel mixture.

IMPROVED COMBUSTION (IMCO) SYSTEM

Standard equipment on most Ford engines, the IMCO system has been further improved for 1970. With IMCO, exhaust emissions are controlled with distributor and carburetor calibration plus design of combustion chambers, air intake system, exhaust system and camshaft. This results in more complete combustion to lower the emission to an acceptable level.

Refinements for 1970 include—

A solenoid throttle modulator which holds the throttle open to a given position on deceleration after having accelerated above 28 mph. The solenoid deactivates after the speed is lowered below 20 mph. This helps maintain the proper air-fuel ratio during deceleration and reduces emission from an over-rich mixture. This device is on all engines with manual transmission except the 390 2V, California only Bronco's with 302 2V, and all engines with automatic transmissions and air conditioning except the 429 4V.

FOR 1970...

A distributor modulator is on 240, 302 2V and 351 4V and 390 2V CID engines with automatic transmissions. This modulator system eliminates engine vacuum advance below 23 mph on acceleration and below approximately 18 mph on deceleration to promote more complete combustion.

THERMACTOR SYSTEM

Also developed by Ford to reduce engine exhaust emissions, the Thermactor system is used on the 1970 302, 428 and 429 CID 4V high performance engines and the 460 CID V-8. The Thermactor exhaust emission control system uses an after-burning fresh-air system in the engine exhaust.

- **Fresh Air Injection**—Pumped into the hot exhaust stream as it leaves the combustion chamber through exhaust valves, fresh air combines with the unburned carbon monoxide and hydrocarbons, completing the reduction of exhaust emissions.
- **Exhaust Gases**—United chemically with oxygen in the fresh air supply, the exhaust gases form harmless carbon dioxide and water.
- **Major Components**—Major components of the Thermactor system include a belt-driven air pump, check valves, rubber hoses, an air distribution manifold for each bank of cylinders, and air injection tubes.

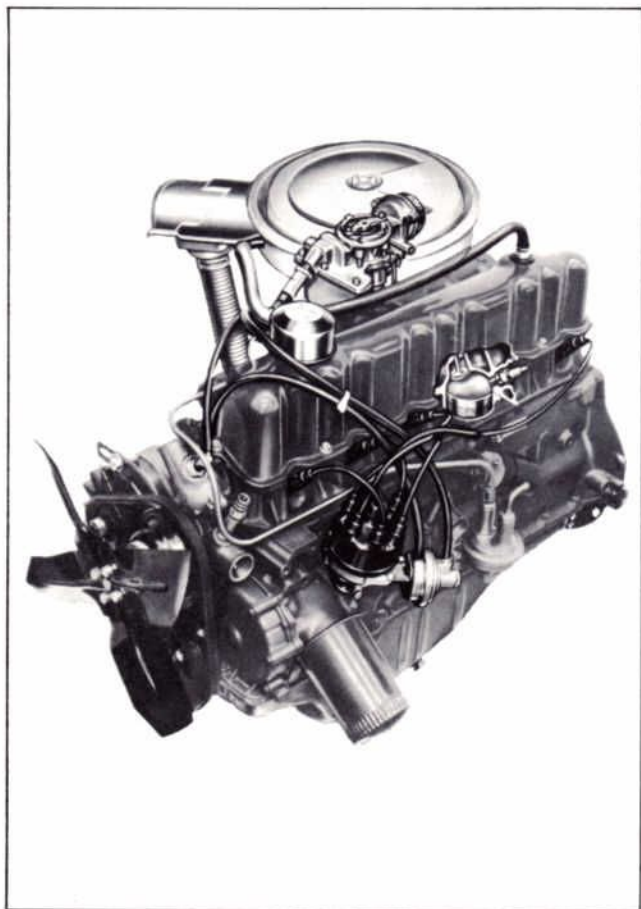

1970 SERVICE TIPS

TWO SPARK PLUG SIZES USED IN 1970 ENGINES

Most 1970 engines will continue to use the conventional 18mm diameter thread Autolite spark plugs as original equipment. However, the 302 Boss, 351 2V & 4V, 429 4V CJ, and 429 Boss engines use a 14mm diameter thread. The smaller thread size allows more room for water cooling

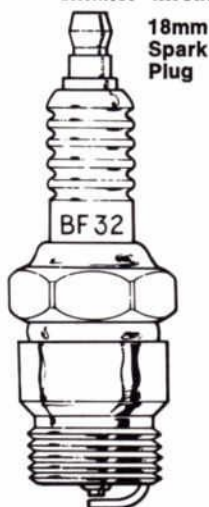

passages and better spark plug location for improved combustion. The first letter of the Autolite Part Number for these plugs is an "A" (AF-32 for example). The equivalent spark plug with 18mm threads would be identified as BF-32. Tighten the spark plugs as follows:

- 14mm... 5-10 lb-ft Torque
- 18mm... 15-20 lb-ft Torque

CARBURETOR THROTTLE SOLENOID MODULATORS

Carburetor throttle solenoid modulators were introduced on a limited number of 1969 engines to improve engine shut-down. They have been greatly expanded in use for 1970, to the point where just about all engines use them (generally, with air conditioning and automatic transmission). On engine shut-down, a solenoid plunger closes the throttle plates in TWO steps. Instead of going directly from a high rpm to engine off, the plunger holds the plates open to a specified rpm while the solenoid is energized. When the ignition is turned off, the solenoid de-energizes, the plunger withdraws, and the throttle plates close further than if no solenoid were used. This more effectively shuts off the air/fuel mixture flow. Carburetors with a throttle solenoid modulator are characterized by a higher and lower curb idle specification (700-500 for example). The higher rpm is obtained by turning an "energized" solenoid in or out of its bracket. The lower curb idle rpm is obtained by disconnecting the solenoid lead wire at the bullet connector and adjusting the throttle stop screw.

THROTTLE SOLENOID "ENERGIZED"

ADJUST "RUNNING" IDLE RPM BY MOVING SOLENOID IN BRACKET TO POSITION SOLENOID PLUNGER AGAINST THROTTLE LEVER

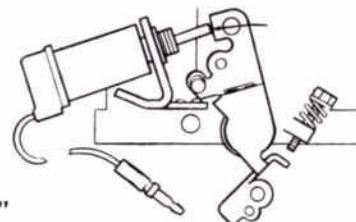

"DE-ENERGIZED"

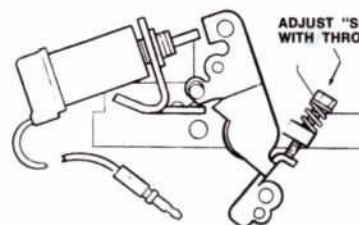

ADJUST "SHUTDOWN" IDLE RPM WITH THROTTLE STOP SCREW

1970 MAINTENANCE SCHEDULES . . .

• FORD • FAIRLANE • FALCON • MAVERICK • MUSTANG • THUNDERBIRD

SCHEDULED MAINTENANCE SERVICES

(These scheduled maintenance services should be performed as indicated to keep the car operating at peak performance.)

Maintenance Operation	Service Interval							
	6	12	18	24	30	36	42	48
ENGINE								
Change engine oil and filter.	X	X	X	X	X	X	X	X
Clean crankcase oil filler breather cap. ¹	X	X	X	X	X	X	X	X
Replace fuel system filter and check fuel line connections for leaks.		X		X		X		X
Replace carburetor air cleaner filter (6 cyl. only). ¹		X		X		X		X
Replace carburetor air cleaner filter (8 cyl. only). ¹				X				X
Drain, flush and refill engine coolant. ²	Every 24 Months							
Inspect cooling system hoses for deterioration, leaks and loose hose clamps. Repair and/or replace as required. ^{2 3}		X		X		X		X
Clean crankcase emission system hoses, tubes, fittings, carburetor spacer and replace as necessary. Replace emission control valve.		X		X		X		X
Replace fuel evaporative emission control valve. (California registered vehicles only.) NOTE: If carbon canister is damaged by crushing or accidentally contaminated by oil, paint, or flood water, replace immediately before next scheduled maintenance interval.		X		X		X		X
Inspect and clean (as necessary) crankcase emission system filter element. ⁴	X	X	X	X	X	X	X	X
Check mechanical valve lifter clearance and adjust if required (if so equipped).		X		X		X		X
Inspect Thermactor exhaust emission system hoses and replace if required.		X		X		X		X
Check exhaust control valve for free operation (if so equipped). (240, 428 & 429)	X	X	X	X	X	X	X	X
Check and adjust distributor points—replace as required.		X		X		X		X
Check and adjust carburetor-idle speed, fuel mixture.		X		X		X		X
Check choke external linkage.		X		X		X		X
Check and adjust ignition timing—initial timing, mechanical and vacuum advance and vacuum retard (if so equipped).		X		X		X		X
Inspect ignition wiring (secondary) for proper installation and good condition.		X		X		X		X
Inspect, clean, adjust and test spark plugs—replace as required.		X		X		X		X
Torque intake manifold bolts to specifications (8 cyl. only).		X		X		X		X
Check drive belt for tension and wear and adjust or replace—if required.		X		X		X		X
CHASSIS AND TRANSMISSION								
Check steering linkage joints for abnormal looseness or damaged seals (Ford only).		X		X		X		X
Lubricate steering linkage (Ford and Thunderbird only).						X		
Lubricate front suspension ball joints (Except Maverick).						X		
Lubricate front suspension ball joints (Maverick only).						X		
Lubricate power steering control valve ball stud (Torino, Mustang and Falcon).					X			
Check transmission oil level. ²	X	X	X	X	X	X	X	X
Adjust automatic transmission front (intermediate) band and rear (reverse) band.		X						
Adjust automatic transmission front and rear band when used in severe service. (Police, Taxi, etc.)	X	X				X		
Check rear axle fluid level. ²	X	X	X	X	X	X	X	X
Clean and repack front wheel bearings.				X ⁵	X ⁶			X ⁵
Check power steering reservoir fluid level. ²	X	X	X	X	X	X	X	X
Inspect and adjust clutch linkage "free play" (if so equipped).	X	X	X	X	X	X	X	X
Check brake lines and lining.				X ⁵	X ⁶			X ⁵
Check brake master cylinder fluid level. ²	X	X	X	X	X	X	X	X
Lubricate steering arm stops.	X	X	X	X	X	X	X	X
BODY								
Lubricate all lock cylinders.	X	X	X	X	X	X	X	X
Lubricate all hinges, hinge checks, hood latch and auxiliary latch.	X	X	X	X	X	X	X	X

MAINTENANCE NOTES: ¹ More frequent service intervals will be required if the vehicle is operated in extremely dusty or low temperature areas, or for extended periods of idling, trailer towing, or short runs which prevent the engine from reaching normal operating temperature.

² Add fluid if required.

³ The cooling system should be inspected each 12,000 miles, or 12 months. If coolant is dirty or rusty in appearance, the system should be cleaned and flushed. The radiator cap should be cleaned and the system refilled with the prescribed solution.

⁴ 351 engine only has emission filter element in air cleaner assembly. Inspect element and replace as necessary. Do not exceed 24,000 miles with one element.

⁵ Fairlane, Falcon, Mustang and Maverick.

⁶ Ford and Thunderbird.

NON-SCHEDULED MAINTENANCE ALL CAR LINES

- Lubricate automatic transmission shift linkage.
- Lubricate manual transmission shift control and linkage.
- Check coolant level.
- Check all fuel, vacuum, hydraulic lines, fittings and connections for leaks.

MAINTENANCE SCHEDULES ... 1970

• COUGAR • MONTEGO • MERCURY • LINCOLN CONTINENTAL • CONTINENTAL MARK III

SCHEDULED MAINTENANCE SERVICES

(These scheduled maintenance services should be performed as indicated to keep the car operating at peak performance.)

Maintenance Operation	Service Interval							
	6	12	18	24	30	36	42	48
ENGINE								
Change engine oil and filter.	X	X	X	X	X	X	X	X
Clean crankcase oil filler breather cap. ¹	X	X	X	X	X	X	X	X
Replace carburetor air cleaner filter (6 cyl. only). ¹		X		X		X		X
Replace carburetor air cleaner filter (8 cyl. only).				X				X
Drain, flush and refill cooling system. ³	Every 24 Months							
Inspect cooling system hoses for deterioration, leaks and loose hose clamps. Repair and replace as required. ^{2 3}		X		X		X		X
Replace crankcase emission filter element. (351 engine only—element in air cleaner assy.)		X		X		X		X
Check mechanical valve lifter clearance and adjust if required (if so equipped).	X	X	X	X	X	X	X	X
Clean crankcase emission system hoses, tubes, fittings, carburetor spacer and replace as necessary. Replace emission control valve.		X		X		X		X
Check battery fluid level.	X	X	X	X	X	X	X	X
CHASSIS AND TRANSMISSION								
Lubricate steering linkage (Mercury only).						X		
Clean and replace as necessary Ride Leveler air filter.	X	X	X	X	X	X	X	X
Lubricate power steering control valve stud (Cougar and Mercury Montego only).						X		
Lubricate front suspension ball joints.						X		
Check transmission oil level. ²	X	X	X	X	X	X	X	X
Check rear axle fluid level. ²	X	X	X	X	X	X	X	X
Clean and repack front wheel bearings.					X			
Check power steering reservoir fluid level. ²	X	X	X	X	X	X	X	X
Inspect and adjust clutch linkage "free-play" (if so equipped).	X	X	X	X	X	X	X	X
Check brake lines and lining.		X		X		X		X
Check tire pressure.	X	X	X	X	X	X	X	X
Adjust automatic transmission front (intermediate) band and rear (reverse) band (if so equipped).		X						
Adjust automatic transmission front and rear bands when used with 428-4V and 429-4V C.J. engines or severe service (police, taxi, etc.)		X ⁴		X		X		
Check brake master cylinder fluid level. ²	X	X	X	X	X	X	X	X
Lubricate steering arm stops.	X	X	X	X	X	X	X	X
BODY								
Lubricate all lock cylinders.	X	X	X	X	X	X	X	X
Lubricate all hinges, hinge checks, hood latch and auxiliary latch.	X	X	X	X	X	X	X	X

- MAINTENANCE NOTES:** ¹ More frequent service intervals will be required if the vehicle is operated in extremely dusty areas or for extended periods of idling, trailer towing, or short runs which prevent the engine from reaching normal operating temperature.
² Add fluid if required.
³ The cooling system should be inspected each 12,000 miles, or 12 months. If coolant is dirty or rusty in appearance, the system should be cleaned and flushed. The radiator cap should be cleaned and the system refilled with the prescribed solution.
⁴ At first 6000 miles or at first oil change (whichever occurs first).

AIR POLLUTION CONTROL SERVICES

(These services are required every 12,000 miles or 12 months to keep air pollutants emitted from the engine within legally established limits.)

ENGINE SYSTEMS PERFORMANCE CHECKS

- Check and adjust distributor points—replace as required.
- Check drive belts for excessive wear or defects—adjust as required.
- Check and adjust carburetor-idle speed, fuel mixture.
- Clean choke external linkage.

- Check and adjust ignition timing—initial timing, and vacuum retard (if so equipped).
- Inspect ignition wiring (secondary) for proper installation and good condition.
- Inspect, clean, adjust and test spark plugs—replace as required.
- Inspect fuel lines and filter for leaks. Replace fuel filter.
- Torque intake manifold bolts to specifications (8 cyl. only).
- Inspect Thermactor exhaust emission system hoses if so equipped and replace if required.
- Replace fuel tank vent valve assembly¹ (California registered vehicles only). Note: If carbon canister is damaged by crushing or accidentally contaminated by oil, paint or flood water, replace immediately before scheduled maintenance interval.

- Check front wheel alignment and steering linkage. Balance wheels.
- Check parking brake cable tension and adjust if required.
- Inspect and rotate wheels and tires.
- Check convertible top fluid.

- Check air conditioning.
- Clean body drain holes and examine dust valves for proper operation.
- Replace windshield wiper blades.
- Check headlight alignment.

1970 Cougar

MODELS AND SPECIFICATIONS



MODELS

- 2-DOOR HARDTOP
- CONVERTIBLE
- 2-DOOR HARDTOP ELIMINATOR
- XR-7 2-DOOR HARDTOP
- XR-7 CONVERTIBLE

IDENTIFICATION

The official Vehicle Identification Number for title and registration purposes is stamped on a tab riveted to the instrument panel close to the windshield on the driver's side of the car and is visible from the outside.

This and other important identifying information is shown on the Vehicle Certification Label that is attached to the rear face of the driver's door. This label is made of a special material and tampering, alteration or removal will result in its destruction or the appearance of the word VOID.

SERVICE LOCATIONS

GAS FILLER CAP—Behind Rear License Plate
 OIL FILLER CAP—Front of Left Rocker Arm Cover
 PCV VALVE—Rear of Right Rocker Arm Cover
 FUSE PANEL—On dash panel, forward and above accelerator pedal
 HOOD LATCH—Lower Center of Grille
 To Open: Pull Lever Out and Hold, Raise Hood

GENERAL DIMENSIONS

Wheelbase.....	111.1"
Tread.....	
Front.....	58.5"
Rear.....	58.5"
Over-all Length.....	196.1"
Over-all Width.....	74.1"
Over-all Height (Loaded) Hardtop.....	51.6"
Convertible.....	51.5"

APPROXIMATE REFILL CAPACITIES

(U.S. Measure)

Fuel Tank.....	22 gal.
With Evaporative Emission System.....	20 gal.
Cooling System (Includes 1 qt. for heater)	
302 CID.....	15.0 qts.
351 CID.....	14.6 qts.
351 CID with A/C.....	16.1 qts.
428 CID.....	19.3 qts.
Engine Crankcase (Includes 1 qt. for filter)	
All.....	5 qts.
Transmission.....	
3-Speed Manual.....	3.5 pts.
4-Speed Manual.....	4 pts.
Select-Shift Merc-O-Matic.....	
351 CID.....	11 qts.
428 CID.....	12¾ qts.
Rear Axle.....	5 pts.

LIGHTS (12 VOLTS)

Lamp Description	Candle Power or Wattage	Lamp Number
Standard Equipment		
Headlights		
Hi-Lo Beam.....	37.5 & 50 Watts	4002
Hi Beam.....	37.5 Watts	4001
Front Parking/Turn Signal.....	3-32 c.p.	1157A
Rear Stop/Tail/Turn Signal.....	3-32 c.p.	1157
License Plate.....	4 c.p.	97

LIGHTS (12 VOLTS) continued

Lamp Description	Candle Power or Wattage	Lamp Number
Standard Equipment continued		
Front Side Marker.....	4 c.p.	97NA
Rear Side Marker.....	2 c.p.	194
Courtesy Under Panel.....	6 c.p.	562
Courtesy "C" Pillar.....	12 c.p.	105
Auto. Trans. Quadrant.....	1.5 c.p.	1445
Door Courtesy.....	6 c.p.	212
Console Lamp.....	3 c.p.	1816
Luggage Compartment.....	6 c.p.	631
Back-up Light.....	32 c.p.	1156
Instrument Panel		
All (Unless otherwise shown).....	2 c.p.	194
Ash Tray.....	1.5 c.p.	1445
Ash Tray—Console.....	1.3 c.p.	1892
Clock.....	2 c.p.	1895
Glove Compartment & Map.....	3 c.p.	1816
Accessory Equipment		
Radio AM/FM & AM.....	1.9 c.p.	1893
Radio AM—Tape Player.....	1.9 c.p.	1893
Spotlight.....	30 Watts	4405
Heater—A/C Controls.....	1.5 c.p.	1445
Engine Compartment.....	6 c.p.	631
Visual Check Panel (except XR-7)		
Low Fuel Warning.....	2 c.p.	1895
Door Ajar Warning.....	1.6 c.p.	257
Seat Belt Reminder.....	2 c.p.	1895
Brakes and Parking Brake Warning.....	2 c.p.	194
Lights, Oil and Alternator.....	2 c.p.	194
XR-7 Models		
All Lamps.....	2 c.p.	194
NA—Natural Amber Color Bulb		
A—Amber Color Bulb		

CIRCUIT PROTECTION

Circuit	Location	Rating Amperes	Type Fuse or C.B.*
Headlights.....	Integral with Light Switch	18	C.B.
Parking, Tail & License Lights, Horns, Auto. Trans. Quadrant & Side Marker.....	Integral with Light Switch	15	C.B.
Power Windows & Power Top Feed Circuit.....	Starter Motor Relay	20	C.B.
Heater & Defroster.....	Fuse Panel	14	SFE
Air Conditioning.....	Fuse Panel	30	SFE
Rear Lamp Feed Wire.....	In Trunk	5	C.B.
Windshield Wiper.....	Integral with Wiper Switch	6	C.B.
Emergency Warning & Stop Lights.....	L.H. of Instrument Panel	15	C.B.
Back-up Lights, Turn Signals, Radio Feed, Auto. Trans. Quadrant & Windshield Washer.....	Fuse Panel	15	SFE
Lights for Instrument Panel, A/C, Radio, Heater Control, Clock and Ash Tray.....	Fuse Panel	4	AGA
Lighter Feed, Courtesy, Glove Compartment, Map, Luggage Compartment, Clock Feed.....	Fuse Panel	14	SFE
Power Window Relay Feed, Accy. Feed, Seat Belt Reminder, Door Ajar, Low Fuel, and Rear Window Defogger.....	Fuse Panel	15	SFE
Spotlight.....	Cartridge in Feed Wire	7.5	SFE
Engine Compt.....	Cartridge in Feed Wire	7.5	SFE
Emission Control and/or Carburetor Solenoid.....	Fuse Panel	14	SFE
Motors: Windshield Wiper, Power Windows & Power Seat.....	Integral with Motor		C.B.

*C.B.—Circuit Breaker



1970 Cougar

MODELS AND SPECIFICATIONS

RECOMMENDED TIRE SIZE and INFLATION PRESSURE (cold)

Model	Engine C.I.D. Size	Standard Tire			Optional Tire		
		Size (load Range B)	Pressure		Size (Load Range B)	Pressure	
			Front	Rear		Front	Rear
Std. & XR-7 Hard Tops & Convertibles	302, 351	E78-14	26	26	F70-14	28	28
Std. & XR-7 Hard Tops & Convertibles	428	F70-14	28	28	—	—	—
Eliminators	All	F70-14	28	28	—	—	—
Full Rated (Maximum) Load							
Models	Total Load—Occupants Plus Luggage						
	Maximum Load (Lbs.)	Total Occupants	Distribution			Luggage	
			Front	Rear			
All	775	4	2	2	175 Lbs.		

FOR SUSTAINED HIGH SPEEDS OR TRAILER TOWING—SEE OWNER'S MANUAL

ENGINE SPECIFICATIONS

	302 BOSS	351 CID V-8 2V	351 CID V-8 4V	428 CID 4V CJ	429 BOSS
Type.....	8-Cyl. 90° V OHV	8-Cyl. 90°V OHV	8-Cyl. 90°V OHV	8-Cyl.90°V OHV	8-Cyl. 90°V OHV
Displacement.....	302 Cu. In.	351 Cu. In.	351 Cu. In.	428 Cu. In.	429 Cu. In.
Bore and Stroke (Inches).....	4.00 x 3.00	4.00 x 3.50	4.00 x 3.50	4.13 x 3.98	4.36 x 3.59
Compression Ratio.....	10.6:1	9.5:1	11.4:1	10.6:1	10.5:1
Brake Horsepower @ Specified rpm.....	290 @ 5800	250 @ 4600	300 @ 5400	335 @ 5200	375 @ 5200
Maximum Torque (lb-ft) @ Specified rpm.....	290 @ 4300	355 @ 2600	380 @ 3400	440 @ 3400	490 @ 3400
Valve Lifters.....	Mechanical	Hydraulic	Hydraulic	Hydraulic	Mechanical
Fuel.....	Premium	Regular	Premium	Premium	Premium
Carburetor.....	Manual Choke 4V	Auto. Choke 2V	Auto. Choke 4V	Auto. Choke 4V	Manual Choke 4V
Firing Order.....	1-5-4-2-6-3-7-8	1-3-7-2-6-5-4-8	1-3-7-2-6-5-4-8	1-5-4-2-6-3-7-8	1-5-4-2-6-3-7-8
Spark Plug Type (Autolite No.) and Size.....	AF-32 (14mm)	AF-42 (14mm)	AF-32 (14mm)	BF-32 (18mm)	AF-32 (14mm)
Spark Plug Gap.....	0.032"-0.036"	0.032"-0.036"	0.032"-0.036"	0.032"-0.036"	0.032"-0.036"
Distributor					
Point Gap.....	0.020" dual points	0.021"	0.021"	0.017" (A/T) 0.020" (S/T) dual points 0.021" (S/T)	0.020" dual points
Point Dwell.....	30°-33°	24°-29°	24°-29°	26°-31° (A/T) 30°-33° (S/T) dual points 24°-29° (S/T)	30°-33°
Distributor Diaphragm Type.....	Dual	Dual	Dual	Single (A/T) Dual (S/T)	Dual
Idle rpm (1)					
Manual Transmission					
(Without Throttle Solenoid).....	—	—	—	725	700
(With Throttle Solenoid).....	800-500	750-500	800-500	725-500	700-500
Automatic Transmission					
(Without Throttle Solenoid).....	—	600	600	675	—
(With Throttle Solenoid).....	—	600-500	600-500	675-500	—
Ignition Timing (BTDC) (2), (3).....	16°	6°	6°	6°	10°
Manifold Vacuum (Idle) Minimum "Hg" (4)....	16	15	15	15	17
A/T—(Automatic Transmission)					
S/T—(Synchromesh Transmission)					

ENGINE NOTES:

- Adjust all idle speeds with headlights "ON", automatic transmission in "DRIVE" or manual transmission in "NEUTRAL", and if air conditioner equipped, with A/C in "OFF" position. Adjust high idle speed with throttle solenoid operating. Adjust low idle speed with wire disconnected from throttle solenoid.
- The distributor diaphragm hose or hoses must be disconnected and plugged.
- If the individual requirements of the vehicle and/or use of sub-standard fuels dictate, the initial timing may have to be retarded from the "normal" setting to eliminate detonation. If retarding is necessary, it should be done progressively and not exceed 2° BTDC.
- Subtract one inch of mercury for engines equipped with dual diaphragm distributors.

1970 Mercury Montego

MODELS AND SPECIFICATIONS



MODELS

- MONTEGO BROUGHAM
- CYCLONE GT
- CYCLONE SPOILER
- MONTEGO
- MONTEGO MX
- CYCLONE

IDENTIFICATION

The official Vehicle Identification Number for title and registration purposes is stamped on a tab riveted to the instrument panel close to the windshield on the driver's side of the car and is visible from the outside.

This and other important identifying information is shown on the Vehicle Certification Label that is attached to the rear face of the driver's door. This label is made of a special material and tampering, alteration or removal will result in its destruction or the appearance of the word VOID.

GENERAL DIMENSIONS

Wheelbase		
All Models except Station Wagon	117.0"	
Station Wagon	114.0"	
Tread		
Front	60.5"	
Rear	60.0"	
Over-all Length		
All Models except Station Wagon	209.9"	
Station Wagon	211.8"	
Over-all Width		
All Models except Station Wagon	77.3"	
Station Wagon	75.4"	
Over-all Height		
Sedan	53.2"	
Hardtop	52.4"	
Station Wagon	55.9"	

APPROXIMATE REFILL CAPACITIES

(U.S. Measure)

Fuel Tank		
All Models except Station Wagon	22 gal.	
Station Wagon	19 gal.	
With Evaporative Emission System		
All Models except Station Wagon	20 gal.	
Station Wagon	17 gal.	
Cooling System (Includes 1 qt. for heater) (without A/C or Extra Cooling)		
250 CID	11½ qts.	
302 CID	15¼ qts.	
351 CID	15½ qts.	
429 CID (except CJ & Boss)	19 qts.	
429 (CJ & Boss)	19¾ qts.	
(With A/C or Extra Cooling)		
351 CID	15¾ qts.	
429 CID	19¾ qts.	
Engine Crankcase (Includes 1 qt. for filter)		
250 CID	4½ qts.	
302, 351 & 429 (except Boss) CID	5 qts.	
429 Boss (add 1 qt. for oil cooler)	7 qts.	
Transmission		
3-Speed Manual	3½ pts.	
4-Speed Manual	4 pts.	
Select-Shift Merc-O-Matic (Dry System)		
250 & 302 CID	9 qts.	
351 CID	11 qts.	
429 CID	12¾ qts.	
Rear Axle		
250 & 302 CID	4 pts.	
351 & 429 CID	5 pts.	

SERVICE LOCATIONS

GAS FILLER CAP—Left Rear Fender
 OIL FILLER CAP—6-Cylinder: Front of Rocker Arm Cover
 —8-Cylinder: Front of Left Rocker Arm Cover
 PCV VALVE—6-Cylinder: Rear of Rocker Arm Cover
 —8-Cylinder: Rear of Right Rocker Arm Cover
 FUSE PANEL—On dash panel to left of steering column
 HOOD LATCH—Top Center of Grille
 To Open: Pull Lever to Right, Raise Hood

LIGHTS (12 VOLTS)

Lamp Description	Candle Power or Watts	Lamp Number
Standard Equipment		
Headlights		
Hi-Lo Beam	37.5 & 50 Watts	4002
Hi-Beam	37.5 Watts	4001
Front Park & Turn Signal	3-32 c.p.	1157A
Rear Stop & Turn Signal	3-32 c.p.	1157
Back-up Light	32 c.p.	1156
Front and Rear Side Marker	2 c.p.	194
License Plate	4 c.p.	97
Dome	12 c.p.	105
Instrument Panel		
All (Unless otherwise shown)	2 c.p.	194
Radio Dial	2 c.p.	1893
Clock	2 c.p.	1895
Auto. Trans. Quadrant	1.5 c.p.	1445
Ash Tray	1.5 c.p.	1445
Accessory Equipment		
Glove Compartment	2 c.p.	1891
Engine Compartment	6 c.p.	631
Spotlight	30 Watts	4405
Cargo (Station Wagon)	12 c.p.	105
Luggage Compartment	12 c.p.	105
Tachometer	2 c.p.	1895
Courtesy (Instrument Panel)	6 c.p.	562
Cluster	2 c.p.	1895
A—Amber Color Bulb		

CIRCUIT PROTECTION

Circuit	Location	Rating Amperes	Type Fuse or C.B.*
Headlights	Integral with Light Switch	18	C.B.
Tail Lights, Stoplights, Horns, License & Marker Light	Integral with Light Switch	15	C.B.
Emergency Flasher, Cigar Lighter & Clock Feed	Fuse Panel	20	SFE
Lights for Courtesy, Dome, Map, Cargo, Luggage & Glove Comp.	Fuse Panel	14	SFE
Instrument Cluster Lights	Fuse Panel	4	AGA
Warning Lights, Throttle Solenoid, Oil, Dual Brake	Fuse Panel	14	SFE
Warning & Temperature Heater	Fuse Panel	14	SFE
Air Conditioning	Fuse Panel	30	SFE
Back-up Lights, Windshield Washer & Radio	Fuse Panel	20	SFE
Accessory Feed (RPO) & Seat Belt Reminder (RPO)	Fuse Panel	20	SFE
Windshield Wiper	Integral with Wiper Switch		C.B.
Power Windows, Power Seat Adjuster & Power Backlite	On Starter Relay	20	C.B.
Spotlight	Fuse Cartridge in Feed Wire	7.5	SFE
Parking Brake Warning Light & Auto. Trans. Console	Fuse Cartridge in Feed Wire	4	SFE
Motors: Windshield Wiper, Power Windows	Integral with Motor		C.B.

*C.B. Circuit Breaker



1970 Mercury Montego

MODELS AND SPECIFICATIONS

RECOMMENDED TIRE SIZE and INFLATION PRESSURE (cold)

Model	Engine C.I.D. Size	Standard Tire			Optional Tire		
		Size (Load Range B)	Pressure Front	Pressure Rear	Size (Load Range B)	Pressure Front	Pressure Rear
Montego Sedans & Hardtops	250, 302	E78-14	27	29	F78-14	26	28
					F70-14	28	28
					G70-14	28	28
	351	F78-14	26	28	G78-14	24	26
					F70-14	28	28
					G70-14	28	28
429	G78-14	26	28	G70-14	28	28	
Montego MX & Montego MX Brougham Sedans & Hardtops	250, 302, 351	F78-14	26	28	G78-14	24	26
					F70-14	28	28
	429	G78-14	26	28	G70-14	28	28
					F70-14	28	28
Cyclone GT, Cyclone & Cyclone Spoiler	351	F70-14	28	28	G70-14	28	28
	429	G70-14	28	28	—	—	—
Station Wagons	All	G78-14	22	32	—	—	—
FULL RATED (MAXIMUM) LOAD							
Model	Total Load—Occupants Plus Luggage						
	Maximum Load (lbs.)	Total Occupants	Distribution				Luggage
			Front	Center	Rear		
Station Wagons	1200	6	3	3	0	300 Lbs.	
	1200	8	3	3	2	0	
FOR SUSTAINED HIGH SPEEDS OR TRAILER TOWING—SEE OWNER'S MANUAL							

ENGINE SPECIFICATIONS

	250 CID I-6	302 CID V-8 2V	351 CID V-8 2V	351 CID V-8 4V	429 CID 4V	429 CID 4V CJ	429 BOSS
Type	In Line 6-Cyl.	8-Cyl. 90°V OHV	8-Cyl. 90°V OHV	8-Cyl. 90°V OHV	8-Cyl. 90°V OHV	8-Cyl. 90°V OHV	8-Cyl. 90°V OHV
Displacement	250 Cu. In.	302 Cu. In.	351 Cu. In.	351 Cu. In.	429 Cu. In.	429 Cu. In.	429 Cu. In.
Bore and Stroke (Inches)	4.00 x 3.91	4.00 x 3.00	4.00 x 3.50	4.00 x 3.50	4.36 x 3.59	4.36 x 3.59	4.36 x 3.59
Compression Ratio	9.0:1	9.5:1	9.5:1	11.4:1	10.5:1	11.0:1	10.5:1
Brake Horsepower @ Specified rpm	155 @ 4000	220 @ 4600	250 @ 4600	300 @ 5400	360 @ 4600	345 @ 5400 355 @ 5600	375 @ 5200
Max. Torque (lb-ft) @ Specified rpm	240 @ 1600	300 @ 2600	355 @ 2600	380 @ 3400	480 @ 2800	450 @ 3400	490 @ 3400
Valve Lifters	Hydraulic	Hydraulic	Hydraulic	Hydraulic	Hydraulic	Hydraulic	Mechanical
Fuel	Regular	Regular	Regular	Premium	Premium	Premium	Premium
Carburetor	Auto. Choke 2V	Auto. Choke 2V	Auto. Choke 2V	Auto. Choke 4V	Auto. Choke 4V	Auto. Choke 4V	Manual Choke 4V
Firing Order	1-5-3-6-2-4	1-5-4-2-6-3-7-8	1-3-7-2-6-5-4-8	1-3-7-2-6-5-4-8	1-5-4-2-6-3-7-8	1-5-4-2-6-3-7-8	1-5-4-2-6-3-7-8
Spark Plug Type (Autolite No.) and Size	BF-82 (18mm)	BF-42 (18mm)	AF-42 (14mm)	AF-32 (14mm)	BF-42 (18mm)	AF-32 (14mm)	AF-32 (14mm)
Spark Plug Gap	0.032"-0.036"	0.032"-0.036"	0.032"-0.036"	0.032"-0.036"	0.032"-0.036"	0.032"-0.036"	0.032"-0.036"
Distributor							
Point Gap	0.027"	0.021"	0.021"	0.021"	0.021"	0.021"	0.020" dual points
Point Dwell	35°-40°	24°-29°	24°-29°	24°-29°	24°-29°	24°-29°	30°-33°
Distributor Diaphragm Type	Dual	Dual	Dual	Dual	Dual	Dual	Dual
Idle rpm ¹							
Manual Transmission							
(Without Throttle Solenoid)	550	—	—	—	—	700	700
(With Throttle Solenoid)	750-500	800-500	750-500	800-500	800-500	725-500	700-500
Automatic Transmission							
(Without Throttle Solenoid)	—	575	600	600	600	650	—
(With Throttle Solenoid)	600-500	600-500	600-500	600-500	600-500	675-500	—
Ignition Timing (BTDC) ^{2, 3}	6°	6°	6°	6°	6°	10°	10°
Manifold Vac. (Idle) Minimum "Hg" ⁴	18	16	15	15	17	17	17

ENGINE NOTES:

- Adjust all idle speeds with headlights "ON," automatic transmission in "DRIVE" or manual transmission in "NEUTRAL," and if air conditioner equipped, with A/C in "OFF" position. Adjust high idle speed with throttle solenoid operating. Adjust low idle speed with wire disconnected from throttle solenoid.
- The distributor diaphragm hose or hoses must be disconnected and plugged.
- If the individual requirements of the vehicle and/or use of sub-standard fuels dictate, the initial timing may have to be retarded from the "normal" setting to eliminate detonation. If retarding is necessary, it should be done progressively and not exceed 2° BTDC.
- Subtract one inch of mercury for engines equipped with dual diaphragm distributors.

1970 MERCURY

MODELS AND SPECIFICATIONS



MODELS

- MONTEREY
- MARQUIS BROUGHAM
- COLONY PARK
- MONTEREY CUSTOM
- MARQUIS
- MARAUDER
- MARAUDER X-100

IDENTIFICATION

The official Vehicle Identification Number for title and registration purposes is stamped on a tab riveted to the instrument panel close to the windshield on the driver's side of the car and is visible from the outside.

This and other important identifying information is shown on the Vehicle Certification Label that is attached to the rear face of the driver's door. This label is made of a special material and tampering, alteration or removal will result in its destruction or the appearance of the word VOID.

SERVICE LOCATIONS

- GAS FILLER CAP—Left Rear Fender
- OIL FILLER CAP—Front of Left Rocker Arm Cover
- PCV VALVE—Rear of Right Rocker Arm Cover
- FUSE PANEL—Left Side of Dash Panel
- HOOD LATCH—Top, Left Center of Grille
- To Open: Move Lever to Center of Car, Raise Hood

GENERAL DIMENSIONS

Wheelbase	
All Models except Station Wagon & Marauder	124.0"
Station Wagon & Marauder	121.0"
Tread	
Front	63.0"
Rear	64.0"
Over-all Length	
Sedans, Hardtops & Convertibles	
Monterey	221.8"
Marauder	219.1"
Marquis	224.3"
Station Wagons	
Monterey & Monterey Custom	218.0"
Marquis Colony Park	220.5"
Over-all Width	80.0"
Over-all Height (Loaded)	
4-Door Hardtops—All Models & 4-Door Sedan Marquis	54.0"
4-Door Sedans—Monterey	55.1"
2-Door Hardtops Except Marauder	53.9"
Marauder	53.2"
Convertibles	53.5"
Station Wagons	56.8"

APPROXIMATE REFILL CAPACITIES

(U.S. Measure)

Fuel Tank	
All Models except Station Wagon	24.5 gal.
Station Wagon	22.2 gal.
With Evaporative Emission System	
All Models except Station Wagon	23.0 qts.
Station Wagons	21.1 qts.
Cooling System (Includes 1 qt. for heater)	
With A/C 390 CID	20.5 qts.
428 CID	19.5 qts.
429 CID	19.0 qts.
Without A/C 390 CID	20.0 qts.
428 CID	19.7 qts.
429 CID	19.0 qts.
Engine Crankcase (Includes 1 qt. for filter)	5 qts.
Transmission	
3-Speed Manual	3.5 pts.
Select-Shift Merc-O-Matic	12.7 qts.
Rear Axle	5 pts.

LIGHTS (12 VOLTS)

Lamp Description	Candle Power or Wattage	Lamp Number
Standard Equipment		
Headlights		
Hi-Lo Beam	37.5 & 50 Watts	4002
Hi-Beam	37.5 Watts	4001
Front Parking & Turn Signal	3-32 c.p.	1157
Rear Lamp, Stop and Turn Signal	3-32 c.p.	1157
Front and Rear Side Marker	2 c.p.	194
Back-up	32 c.p.	1156
Dome	12 c.p.	105
License Plate	4 c.p.	97
Courtesy (Convertible)	6 c.p.	631
Cargo (Station Wagon)	12 c.p.	105
Courtesy (Door)	6 c.p.	212
Courtesy (Instrument Panel)	6 c.p.	631
Rear Running Lamp (Station Wagon)	4 c.p.	1095
Instrument Panel		
All (Unless otherwise shown)	2 c.p.	194
Glove Compartment	3 c.p.	1816
Courtesy Lamp	6 c.p.	631
Heater Control	1.5 c.p.	1445
Ash Tray—Instrument Panel	1.5 c.p.	1445
Auto. Trans. Quadrant	1.5 c.p.	1445
Accessory Equipment		
Fog Lamps (Amber)	35 Watts	4415A
Fog Lamp Switch	1 c.p.	161
Map	3 c.p.	1816
Tachometer	2 c.p.	1895
Warning Indicator Panel	2 c.p.	1891
Clock	2 c.p.	194
Engine Compartment	6 c.p.	631
Luggage Compartment	6 c.p.	631
Radio Pilot Light	1.9 c.p.	1893
Spotlight	30 Watts	4405
Air Conditioner	2 c.p.	1895
Cargo Lamp (Station Wagon)	15 c.p.	1003
Radio & Stereo Pilot Light	1.9 c.p.	1893
A—Amber Color Bulb		

CIRCUIT PROTECTION

Circuit	Location	Type Rating Amperes	Fuse or C.B.*
Headlights	Integral with Light Switch	18	C.B.
Lights for Rear Tail, Front Parking, License Plate, Front Side Marker, Horns and Headlamp Buzzer	Integral with Light Switch	15	C.B.
Windshield Wipers	Integral with Wiper Switch	8.25	C.B.
Interval Windshield Wipers	Center Inst. Panel Flange	7	C.B.
Stop Lamps	R.H. Inst. Panel Flange	20	C.B.
Convertible Top with Power Options	On Starter Relay	20	C.B.
Power Windows & Power Seats	On Starter Relay	20	C.B.
Air Conditioner	Instrument Panel	25	C.B.
Rear Window Defroster and Seat Back Latch	On Starter Relay	20	C.B.
Parking Brake Warning, Speed Control, Power Antenna, Power Windows & Defogger	Fuse Panel	20	SFE
Radio, W/S Washer, & Back-up Lights	Fuse Panel	20	SFE
Instrument Cluster Lights, Clock Light, Ash Tray, Auto. Trans. Quadrant, Radio Light and Heater Control Lights	Fuse Panel	4	AGA
Dome, Courtesy, Glove Compartment, Clock, Map, Seat Back Latch & Luggage Compartment	Fuse Panel	14	SFE
Emergency Flasher and Cigar Lighter	Fuse Panel	20	SFE
Heater Blower	Fuse Panel	14	SFE
Air Conditioner (Dealer Inst.)	Cartridge in Feed Wire	20	AGA
Motors: Windshield Wiper, Convertible Top, Power Seats, Power Windows	Integral with Motor		C.B.

*C.B. Circuit Breaker



1970 MERCURY

MODELS AND SPECIFICATIONS

RECOMMENDED TIRE SIZE and INFLATION PRESSURE (cold)

Model	Engine C.I.D. Size	Standard Tire			Optional Tire		
		Size (Load Range B)	Pressure		Size (Load Range B)	Pressure	
			Front	Rear		Front	Rear
Monterey & Monterey Custom Sedans & Hardtops Non A/C	All	G78-15	27	27	8.25-15	27	27
Monterey & Monterey Custom Sedans & Hardtops With A/C	390				H78-15	26	26
Marauder non A/C					H70-15		
Monterey & Monterey Custom Sedans & Hardtops With A/C	All Except 390	H78-15	26	26	8.55-15	26	26
Marquis & Brougham	All						
Marauder—Except 390 Non A/C	All						
Convertibles—Monterey A/C & All Marquis	All						
Station Wagons	All	H78-15	24	32	8.55-15	24	32
Marauder X-100	All	H70-15	26	26	—	—	—

FULL RATED (MAXIMUM) LOAD

Model	Total Load—Occupants Plus Luggage					
	Maximum Load	Total Occupants	Distribution			Luggage
			Front	Center	Rear	
Bench Seat	1100 lbs.	6	3	—	3	200 lbs.
Bucket Seat	950 lbs.	5	2	—	3	200 lbs.
Station Wagons	1200 lbs.	6	3	3	0	300 lbs.
Station Wagons	1200 lbs.	8	3	3	2	0

FOR SUSTAINED HIGH SPEEDS OR TRAILER TOWING— SEE OWNER'S MANUAL

ENGINE SPECIFICATIONS

	390 CID 2V (RF)	390 CID 2V (PF)	429 CID 2V	429 CID 4V
Type	8-Cyl. 90°V OHV	8-Cyl. 90°V OHV	8-Cyl. 90°V OHV	8-Cyl. 90°V OHV
Displacement	390 Cu. In.	390 Cu. In.	429 Cu. In.	429 Cu. In.
Bore and Stroke (Inches)	4.05 x 3.78	4.05 x 3.78	4.36 x 3.59	4.36 x 3.59
Compression Ratio	9.5:1	10.5:1	10.5:1	10.5:1
Brake Horsepower @ Specified rpm	265 @ 4400	280 @ 4400	320 @ 4400	360 @ 4600
Maximum Torque (lb-ft) @ Specified rpm	390 @ 2600	403 @ 3600	460 @ 2200	480 @ 2800
Valve Lifters	Hydraulic	Hydraulic	Hydraulic	Hydraulic
Fuel	Regular	Premium	Premium	Premium
Carburetor	Auto. Choke 2V	Auto. Choke 2V	Auto. Choke 2V	Auto. Choke 4V
Firing Order	1-5-4-2-6-3-7-8	1-5-4-2-6-3-7-8	1-5-4-2-6-3-7-8	1-5-4-2-6-3-7-8
Spark Plug Type (Autolite No.) and Size	BF-42 (18mm)	BF-42 (18mm)	BF-42 (18mm)	BF-42 (18mm)
Spark Plug Gap	0.032-0.036"	0.032"-0.036"	0.032"-0.036"	0.032"-0.036"
Distributor				
Point Gap	0.017"	0.017"	0.021"	0.021"
Point Dwell	26°-31°	26°-31°	24°-29°	24°-29°
Distributor Diaphragm Type	Single	Dual	Dual	Dual
Idle rpm ¹				
Automatic Transmission (without throttle solenoid)	—	—	600	600
(with throttle solenoid)	600-500	600-500	600-500	600-500
Ignition Timing (BTDC) ^{2,3}	6°	6°	6°	6°
Manifold Vacuum (Idle) Minimum "Hg" ⁴	17	17	17	17

ENGINE NOTES:

¹ Adjust all idle speeds with headlights "ON", automatic transmission in "DRIVE", and if air conditioner equipped, with A/C in "OFF" position. Adjust high idle speed with throttle solenoid operating. Adjust low idle speed with wire disconnected from throttle solenoid.

² The distributor diaphragm hose or hoses must be disconnected and plugged.

³ If the individual requirements of the vehicle and/or use of sub-standard fuels dictate, the initial timing may have to be retarded from the "normal" setting to eliminate detonation. If retarding is necessary, it should be done progressively and not exceed 2° BTDC.

⁴ Subtract one-inch of mercury for engines equipped with dual diaphragm distributors.

1970

MODELS AND SPECIFICATIONS

LINCOLN *Continental*



MODELS 2 DOOR HARDTOP IDENTIFICATION

The official Vehicle Identification Number for title and registration purposes is stamped on a tab riveted to the instrument panel close to the windshield on the driver's side of the car and is visible from the outside.

This and other important identifying information is shown on the Vehicle Certification Label that is attached to the rear face of the driver's door. This label is made of a special material and tampering, alteration or removal will result in its destruction or the appearance of the word VOID.

GENERAL DIMENSIONS

Wheelbase.....	117.2"
Tread—Front.....	62.0"
—Rear.....	62.0"
Overall Length.....	216.1"
Overall Width.....	79.4"
Overall Height—Loaded.....	53.0"

SERVICE LOCATIONS

GAS FILLER CAP—Left rear quarter panel
 OIL FILLER CAP—Front of left rocker arm cover
 (PCV) REGULATOR VALVE—Rear of right rocker arm cover
 HOOD LATCH—Lower center of grille
 To Open: Push outward on lever.
 FUSE PANEL—In right side of glove compartment behind removable cover
 CIRCUIT BREAKER—R.H. side of dash panel.

APPROXIMATE REFILL CAPACITIES

(U.S. Measure)

Fuel Tank.....	24.0 gal.
With Evaporative Emission System.....	22.5 gal.
Cooling System (Includes 1 qt. for heater).....	19.5 qts.
Engine Crankcase (Includes 1 qt. for filter).....	5.0 qts.
Power Steering.....	3.9 pts.
Transmission, includes Cooler (dry system)*.....	12.7 qts.
Rear Axle.....	5.0 pts.

*Dipstick used to determine exact fill requirements

CIRCUIT PROTECTION

Circuit	Location	Rating Amperes	Type Fuse or C.B.*
Headlight Circuit.....	Integral with Lighting Switch	18	C.B.
Tail-lights, Running Lights, License Plate Light, Parking Lights, Marker Lights.....	Integral with Lighting Switch	15	C.B.
Instrument Panel and Instrument Cluster Illumination.....	Fuse Panel	6	SFE 6
Clock Feed, Courtesy Lights, Luggage Compartment Light, Glove Compartment Light, Map Light and Reading Lights, Engine Compt. Light.....	Fuse Panel	14	SFE 14
Warning Lights (except Low Fuel Warning).....	Fuse Panel	7.5	SFE 7.5
Low Fuel Warning.....	Fuse Panel	7.5	SFE 7.5
Speed Control and Back up Lights.....	Fuse Panel	7.5	SFE 7.5
Turn Signal.....	Fuse Panel	7.5	SFE 7.5
Power Antenna.....	Fuse Panel	15	3AG 10
Front Cigar Lighter, Radio and Stereo.....	Fuse Panel	15	SFE 15
Rear Cigar Lighter.....	Fuse Panel	15	SFE 15
Sure-Track Brake System.....	Fuse Panel	3	SFE 3
Power Seats, A/C High Speed Blower and Horns.....	Circuit Breaker Panel (Seat and window motors also protected by integral circuit breakers)	30	C.B.
Stop Lights and Emergency Warning.....	Circuit Breaker Panel	10	C.B.
Heater and Air Conditioner.....	Circuit Breaker Panel	30	C.B.
Charging Circuit.....	Fusible Link Block (below starter relay in engine compartment)	Fusible Link	
Power Windows.....	Circuit Breaker Panel	20	C.B.
Rear Window Defroster.....	On Brake Pedal Support	20	C.B.
Windshield Wiper.....	Integral with Switch	—	C.B.

MODELS AND SPECIFICATIONS

LIGHTS (12 VOLTS)

LAMP DESCRIPTION	Candle Power or Wattage	Lamp Number
Headlight—Hi-Lo Beam.....	37.5 & 50 Watts	4002
Headlight—Hi-Beam.....	37.5 Watts	4001
Front Park & Turn Signal.....	3-32 c.p.	1157NA
Rear Tail/Stop/Turn Signal.....	3-32 c.p.	1157
Back-up Light.....	32 c.p.	1156
License Plate Light.....	4 c.p.	97
Rear Seat Reading Light.....	12 c.p.	105
Glove Compartment Light.....	2 c.p.	1895
Transmission Control Selector Indicator Light.....	1.5 c.p.	1445
Door Courtesy Lights.....	6 c.p.	212
Map Light.....	6 c.p.	212
Front Side Marker Light.....	4 c.p.	97NA
Rear Side Marker Light.....	4 c.p.	97
Luggage Compartment Light.....	6 c.p.	90
Overhead Console Warning Lights.....	2 c.p.	1891
Courtesy Lights (Foot Wall).....	6 c.p.	631
Hi-Beam Indicator.....	2 c.p.	194
Turn Signal Indicators.....	3 c.p.	168A
Warning Lights, Brake & Low Fuel.....	2 c.p.	194
Warning Light Rear Window Defroster.....	1.3 c.p.	1892
Instrument Illumination Lights.....	2 c.p.	194
Radio Dial Light.....	1.9 c.p.	1893
Heater/Air Cond./Auto. Climate Control Light.....	2 c.p.	1895
Rear Vent & Wiper Control Lights.....	2 c.p.	194
Cigar Lighter Light.....	2 c.p.	1895
Speed Control Light.....	1 c.p.	53X
Ash Tray Light.....	1.5 c.p.	1445

NA—Natural Amber Color Bulb
A—Amber Color Bulb

RECOMMENDED TIRE SIZE and INFLATION PRESSURE (cold)

Tire Size (Load Range B)	Pressure			
	Front	Rear		
Standard 225-15 Radial	26	26		
Optional 9.15-15	24	24		
Full Rated (Maximum) Load				
Total Load = Occupants Plus Luggage				
Maximum Load (lbs.)	Total Occupants	Distribution		
		Front	Rear	Luggage
1050	6	3	3	150 lbs.
For sustained high speeds or Trailer Towing—See Owner's Manual				

ENGINE SPECIFICATIONS

Type.....	460 CID 4V
Displacement.....	8-Cyl. 90° V OHV
Bore and Stroke (Inches).....	4.36 x 3.85
Compression Ratio.....	10.5:1
Brake Horsepower @ Specified rpm.....	365 @ 4600
Maximum Torque (lb.-ft.) @ Specified rpm.....	500 @ 2800
Valve Lifters.....	Hydraulic
Fuel.....	Premium
Carburetor.....	Auto. Choke 4V
Firing Order.....	1-5-4-2-6-3-7-8
Spark Plug Type (Autolite No.) and Size.....	BF-42 (18mm)
Spark Plug Gap.....	0.032"-0.036"
Distributor	
Point Gap.....	0.017"
Point Dwell.....	26°-31°
Distributor Diaphragm Type.....	Single
Idle rpm ¹	
Automatic Transmission (Without Throttle Solenoid).....	600
(With Throttle Solenoid).....	—
Ignition Timing (BTDC) ^{2,3}	10°
Manifold Vacuum (Idle) Minimum "Hg" ⁴	17"

ENGINE NOTES:

- Adjust all idle speeds with headlights "ON," automatic transmission in "DRIVE," and if air conditioner equipped, with A/C in "OFF" position. Adjust high idle speed with throttle solenoid operating. Adjust low idle speed with wire disconnected from throttle solenoid.
- The distributor diaphragm hose or hoses must be disconnected and plugged.
- If the individual requirements of the vehicle and/or use of sub-standard fuels dictate, the initial timing may have to be retarded from the "normal" setting to eliminate detonation. If retarding is necessary, it should be done progressively and not exceed 2° BTDC.
- Subtract one-inch of mercury for engines equipped with dual diaphragm distributors.

1970 LINCOLN CONTINENTAL

MODELS AND SPECIFICATIONS



MODELS

- 2-DOOR COUPE • 4-DOOR SEDAN

IDENTIFICATION

The official Vehicle Identification Number for title and registration purposes is stamped on a tab riveted to the instrument panel close to the windshield on the driver's side of the car and is visible from the outside.

This and other important identifying information is shown on the Vehicle Certification Label that is attached to the rear face of the driver's door. This label is made of a special material and tampering, alteration or removal will result in its destruction or the appearance of the word VOID.

SERVICE LOCATIONS

- GAS FILLER CAP—Behind Rear License Plate.
- OIL FILLER CAP—Front Center of Engine.
- PCV VALVE—In Tube at Right Rear of Engine.
- FUSE PANEL—Instrument Panel to Right of Glove Box.
- CIRCUIT BREAKERS—Under Instrument Panel, Above Parking Brake.
- HOOD LATCH—Top Right Center of Grille.
- To Open: Pull Hood Release Handle Located at Lower Left of Instrument Panel. Push Hood Latch Inward, Raise Hood.

GENERAL DIMENSIONS

Wheelbase.....	127.0"
Tread	
Front.....	64.3"
Rear.....	64.3"
Over-all Length.....	225.0"
Over-all Width.....	79.6"
Over-all Height	
2-Door Coupe.....	54.5"
4-Door Sedan.....	55.5"

APPROXIMATE REFILL CAPACITIES

(U.S. Measure)

Fuel Tank.....	24 gal.
With Evaporative Emission System.....	23 gal.
Cooling System (Includes 1 qt. for heater).....	19.5 qts.
Engine Crankcase (Includes 1 qt. for filter).....	5 qts.
Transmission, Includes Cooler (Dry System)*.....	13.0 qts.
Rear Axle.....	5 pts.
Power Steering.....	3.9 pts.

*Dipstick used to determine exact fill requirements.

LIGHTS (12 VOLTS)

LAMP DESCRIPTION	Candle Power or Wattage	Lamp Number
Standard Equipment		
Headlights		
Hi-Lo Beam.....	37.5 & 50 Watts	4002
Hi-Beam.....	37.5 Watts	4001
Front Parking & Turn Signal.....	3-32 c.p.	1157A
Front Side Marker.....	2 c.p.	194A
Rear Side Marker.....	2 c.p.	1895
Rear Tail, Stop & Turn Signal.....	3-32 c.p.	1157
Back-up.....	32 c.p.	1156
License Plate.....	4 c.p.	97

Courtesy (Door) Sedan.....	6 c.p.	212
Courtesy (Door) Coupe.....	6 c.p.	212-1
Luggage Compartment.....	6 c.p.	631
Map.....	6 c.p.	212*

*212-1 used in 2-Door

Instrument Panel

Warning Lights.....	2 c.p.	1891
Glove Compartment.....	2 c.p.	1895
Turn Signal Indicator.....	2 c.p.	1895
Hi-Beam Indicator.....	2 c.p.	1895
Heater Control.....	2 c.p.	1895
Courtesy.....	6 c.p.	631
Illumination.....	2 c.p.	1895
Speedometer.....	2 c.p.	1895
Radio AM & AM-FM Stereo.....	2 c.p.	1891
Radio AM Signal Seeking.....	1.9 c.p.	1893
Radio AM Stereo Tape.....	1.9 c.p.	1893
Clock.....	2 c.p.	1895
Engine Compartment.....	6 c.p.	631
Ash Tray.....	1.5 c.p.	1445
Speed Control Illumination.....	1.5 c.p.	1445
Door Lock Nomenclature.....	2 c.p.	1895
Low Fuel Warning.....	2 c.p.	1895
Auto. Trans. Quadrant.....	1.5 c.p.	1445

A—Amber Color Bulb

CIRCUIT PROTECTION

Circuit	Location	Rating Amperes	Type Fuse or C.B.*
Headlights and Door Warning Light.....	Integral with Light Switch	18	C.B.
Lights for Parking, Tail, License Plate, Ash Tray & Markers.....	Integral with Light Switch	15	C.B.
Stoplights & Emergency Warning.....	R.H. Side of Dash Panel	20	C.B.
Electric Seat & Horns.....	R.H. Side of Dash Panel	30	C.B.
Electric Windows.....	R.H. Side of Dash Panel	20	C.B.
Heater, Defroster & Air Conditioner.....	R.H. Side of Dash Panel	30	C.B.
Interior Lights for: Dome, Courtesy, Glove Compartment, Luggage Compartment, Clock, Seat Back Latch, and Map.....	Fuse Panel	15	SFE
Instrument Panel Lights and Auto. Trans. Quadrant.....	Fuse Panel	6	SFE
Rear Window Defroster.....	Fuse Panel	25	SFE
Warning Lights for: Door Ajar, Deck Lid Open, Brake, Low Fuel, & Seat Belt Reminder.....	Fuse Panel	7.5	SFE
Cigar Lighter (Front) and Door Lock Solenoid.....	Fuse Panel	20	AGC
Cigar Lighter Rear.....	Fuse Panel	20	AGC
Speed Control, Rear Window Defogger, W/S Washers.....	Fuse Panel	7.5	SFE
Radio, Power Antenna, Stereo Tape Player.....	Fuse Panel	7.5	SFE
Back-up Lights, Cornering Lights, & Turn Signal.....	Fuse Panel	15	SFE
Sure-Track Brake System.....	Fuse Panel	3	SFE
Automatic Headlight Dimmer.....	Cartridge in Feed Wire	4	SFE
Power Circuit.....	Terminal Junction Block and Starter Motor Relay	14 Gage Wire Fuse	Safety Link
Windshield Wiper.....	Integral with Switch	7.5	SFE
Motors: Power Seat and Power Windows.....	Integral with Motor		C.B.

*C.B. Circuit Breaker



1970 LINCOLN CONTINENTAL

MODELS AND SPECIFICATIONS

RECOMMENDED TIRE SIZE and INFLATION PRESSURE (cold)

Model	Tire Size (Load Range B)	Pressure			
		Front	Rear		
Sedans & Coupe	Standard 9.15-15	24	24		
FULL RATED (MAXIMUM) LOAD					
Models With Bench Seats Bucket Seats	Total Load — Occupants Plus Luggage				
	Maximum Load (lbs)	Total Occupants	Front	Distribution Rear	Luggage
	1100	6	3	3	200 lbs
950	5	2	3	200 lbs	
For Sustained High Speeds or Trailer Towing—See Owner's Manual					

ENGINE SPECIFICATIONS

Type.....	460 CID 4V
Displacement.....	8-Cyl. 90° V OHV
Bore and Stroke (Inches).....	460 Cu. In.
Compression Ratio.....	4.36 x 3.85
Brake Horsepower @ Specified rpm.....	10.5:1
Maximum Torque (lb.-ft.) @ Specified rpm.....	365 @ 4600
Valve Lifters.....	500 @ 2800
Fuel.....	Hydraulic
Carburetor.....	Premium
Firing Order.....	Auto. Choke 4V
Spark Plug Type (Autolite No.) and Size.....	1-5-4-2-6-3-7-8
Spark Plug Gap.....	BF-42 (18mm)
Distributor.....	0.032"-0.036"
Point Gap.....	0.017"
Point Dwell.....	26°-31°
Distributor Diaphragm Type.....	Single
Idle rpm (1)	
Automatic Transmission	
(Without Throttle Solenoid).....	600
(With Throttle Solenoid).....	—
Ignition Timing (BTDC) (2) (3).....	10°
Manifold Vacuum (Idle) Minimum "Hg" (4).....	17

ENGINE NOTES:

- (1) Adjust all idle speeds with headlights "ON," automatic transmission in "DRIVE," and if air conditioner equipped, with A/C in "OFF" position. Adjust high idle speed with throttle solenoid operating. Adjust low idle speed with wire disconnected from throttle solenoid.
- (2) The distributor diaphragm hose or hoses must be disconnected and plugged.
- (3) If the individual requirements of the vehicle and/or use of sub-standard fuels dictate, the initial timing may have to be retarded from the "normal" setting to eliminate detonation. If retarding is necessary, it should be done progressively and not exceed 2°BTDC.
- (4) Subtract one inch of mercury for engines equipped with dual diaphragm distributors.

1970 FORD

MODELS AND SPECIFICATIONS



MODELS

- FORD CUSTOM
- FORD COUNTRY SEDAN
- FORD XL
- RANCH WAGON
- FORD COUNTRY SQUIRE
- FORD LTD
- FORD CUSTOM 500
- FORD GALAXIE 500
- FORD CUSTOM 500 RANCH WAGON
- FORD LTD BROUGHAM

IDENTIFICATION

The official Vehicle Identification Number for title and registration purposes is stamped on a tab riveted to the instrument panel close to the windshield on the driver's side of the car and is visible from the outside.

This and other important identifying information is shown on the Vehicle Certification Label that is attached to the rear face of the driver's door. This label is made of a special material and tampering, alteration or removal will result in its destruction or the appearance of the word VOID.

SERVICE LOCATIONS

- GAS FILLER CAP—Left Rear Fender
- OIL FILLER CAP—6-Cylinder: Front of Rocker Arm Cover
- 8-Cylinder: Front of Left Rocker Arm Cover
- PCV VALVE—6-Cylinder: Rear of Rocker Arm Cover
- 8-Cylinder: Rear of Right Rocker Arm Cover
- FUSE PANEL—On Dash Panel, to Left of Steering Column
- HOOD LATCH—Top Center of Grille
- To Open: Lift Lever, Raise Hood

LIGHTS (12 VOLTS)

Lamp Description	Candle Power or Wattage	Lamp Number
Standard Equipment		
Headlights		
Hi-Lo Beam	37.5 & 50 Watts	4002
Hi-Beam	37.5 Watts	4001
Front Park/Turn Signal/Emergency Flasher	32-3 c.p.	1157A
Rear Stop/Turn Signal/Tail	32-3 c.p.	1157
Front Side Marker	2 c.p.	194
Rear Side Marker	2 c.p.	194
Rear Side Marker—Lower Bulb	12 c.p.	105
License Plate	4 c.p.	97
Cargo Lamp (Station Wagon)	12 c.p.	105
Courtesy (Convertible)	6 c.p.	631
Dome Lamp	12 c.p.	105
Courtesy (Door) (2-Door LTD)	6 c.p.	212
Courtesy ("C" Pillar)	12 c.p.	105
Courtesy (Door) (4-Door LTD)	6 c.p.	631
Back-up—Sedans	32 c.p.	1156
—Station Wagons	32 c.p.	1076
Instrument Panel		
All (except as otherwise shown)	2 c.p.	1895
Glove Box	3 c.p.	1816
Hi-Beam and Turn Signal Indicators	2 c.p.	194
Instrument and Warning Lights (Standard)	2 c.p.	194
Ash Tray	2 c.p.	1891
Seat Belt Warning (R.P.O.)	2 c.p.	1891
Accessory Equipment		
Air Conditioner Controls	2 c.p.	1895
Radio AM/FM Dial Light	2 c.p.	1891
AM/FM MPX Stereo Jewel	1.3 c.p.	1892
AM Stereo Tape	1.9 c.p.	1893
Spotlight	30 Watts	4405
Fog Lamps—Clear	35 Watts	4415
Fog Lamp Switch	1 c.p.	53X
Safety Convenience Lamps	2 c.p.	1895
Engine and Luggage Compartment	6 c.p.	631
Rear Window Defogger	2 c.p.	1895
Rear Window Defroster	2 c.p.	1895
Headlights "ON"	1.6 c.p.	256
Speed Control Switch	1 c.p.	161
Glove Compartment	3 c.p.	1816
Auto. Trans. Quadrant—Console	2 c.p.	1895
Portable Trunk Lamp	15 c.p.	1003
Parking Brake Release Warning	1.6 c.p.	257

A—Amber Color Bulb

GENERAL DIMENSIONS

Wheelbase	121.0"
Tread:	
Front	63.0"
Rear	64.0"
Over-all Length:	
Station Wagons	219.0"
All 2-door models except Convertible	213.9"
Convertible, XL 4-Door Sedan & 4-Door Hardtop LTD	216.0"
Over-all Width:	
All models except 4-Door Sedan & LTD	79.7"
4-door Sedan & LTD	79.8"
Over-all Height:	
4-Door Sedan and LTD	54.9"
2-Door except Convertible XL	53.5"
2-Door Convertible XL	53.8"
Station Wagon	56.8"
4-Door Hardtop LTD	53.6"

APPROXIMATE REFILL CAPACITIES

	(U.S. Measure)
Fuel Tank	
All models except Station Wagon	24½ gal.
Station Wagon	22½ gal.
With Evaporative Emission System	
Car	23½ gal.
Station Wagon	21½ gal.
Cooling System (Includes 1 qt. for heater)	
240 CID	14½ qts.
302 CID	15½ qts.
351 CID	16½ qts.
390 CID	20 qts.
428 CID	19½ qts.
429 CID	18½ qts.
Engine Crankcase (Includes 1 qt. for filter)	
All	5 qts.
Transmission	
3-Speed Manual	3.5 pts.
4-Speed Manual	4 pts.
Cruise-O-Matic	
C-4	10½ qts.
C-6	12½ qts.
Rear Axle	
All except 8½ inch dia. ring gear	5 pts.
8½ inch dia. ring gear	4.5 pts.

CIRCUIT PROTECTION

Circuit	Location	Rating Amperes	Type Fuse or C.B.*
Headlights & High Beam	Integral with Light Switch	18	C.B.
Parking, Stop, Tail, Marker and License Plate Lights; Ignition Switch, Horns, & Lights-on Buzzer	Integral with Light Switch	15	C.B.
Clock Feed, and Lights for Seat Back Latch, Dome, Cargo, Glove Box, Courtesy, Map, Open Door Warning & Luggage Compartments	Fuse Panel	14	SFE
Lights for Clock, Heater Control, A/C Control, Instrument Cluster, Ash Tray, Fuel Gauge, Speed, Turn Indicators, Emission Solenoid, Radio and Auto. Trans. Quadrant	Fuse Panel	4	AGA
Heater and Defroster	Fuse Panel	14	SFE or AGC
Seat Belt & Emergency			
Warning Light	Fuse Panel	20	SFE
Radio Feed, Back-up Lights	Fuse Panel	20	SFE
Electric Wiper Motor Circuit	Integral with Wiper Switch	8.25	C.B.
Intermittent W/S Wiper	Instrument Panel	7	C.B.
Power Windows, Power Seats, Seat Back Latch, Power Backlite & Top			
Air Conditioner—SelectAire	On Starter Relay	20	C.B.
—Economy	Instrument Panel	30	C.B.
Speed Control	Fuse Cartridge in Feed Wire	20	AGC
Spotlight	Fuse Cartridge in Feed Wire	5	AGA
Motors: Window, Seat, Top	Fuse Cartridge in Feed Wire	7.5	SFE
	Integral with Motor		C.B.

*Circuit Breaker



1970 FORD

MODELS AND SPECIFICATIONS

RECOMMENDED TIRE SIZE and INFLATION PRESSURE (cold)

Model	Engine C.I.D. Size	Standard Tire		Optional Tire			
		Size (Load Range B)	Pressure Front Rear	Size (Load Range B)	Pressure Front Rear		
Sedans & Hd. Tps. Non A/C	240, 302, 351	F78-15	27	29	G78-15	24 26	
Sedans & Hd. Tps. A/C Except 2 Dr. H. T. Fst/Bk A/C 2 Dr. H. T. Formal A/C	240, 302				8.55-15 H78-15 H70-15	24 24	
Sedans & Hd. Tps. Non A/C	390, 428, 429	G78-15	26	27	H78-15 H70-15	24 24	
2 Dr. H. T. Fst/Bk A/C 2 Dr. H. T. Formal A/C	240, 302						27 28
Sedans & Hd. Tps. A/C	351, 390						
Convertibles	240, 302, 351						
Sedans & Hd. Tps. A/C	428, 429	H78-15	26	26	H70-15	26 26	
Convertibles	390, 429						
G.T. Options	All	H70-15	28	28	—	— —	

FULL RATED (MAXIMUM) LOAD

MODEL	TOTAL LOAD—OCCUPANTS PLUS LUGGAGE				
	MAXIMUM LOAD	TOTAL OCCUPANTS	DISTRIBUTION		
			FRONT	REAR	LUGGAGE
BENCH SEAT	1100 LBS.	6	3	3	200 LBS.
BUCKET SEAT	950 LBS.	5	2	3	200 LBS.
FOR SUSTAINED HIGH SPEEDS OR TRAILER TOWING—SEE OWNER'S MANUAL					

STATION WAGONS ONLY

Model	Engine C.I.D. Size	Standard Tire		Optional Tire	
		Size (Load Range B)	Pressure Front Rear	Size (Load Range B)	Pressure Front Rear
Station Wagon	All	H78-15	22 32	8.55-15	22 32

FULL RATED (MAXIMUM) LOAD					
Total Load—Occupants Plus Luggage					
Maximum Load (lbs.)	Total Occupants	Distribution			
		Front	Center	Rear	Luggage
1200	6	3	3	0	300 lbs
1200	8	3	3	2	0

ENGINE SPECIFICATIONS

	240 CID I-6	302 CID V-8 2V	351 CID V-8 2V	390 CID 2V (RF)	429 CID 2V	429 CID 4V
Type	In Line 6-Cyl.	8-Cyl. 90°V OHV	8-Cyl. 90°V OHV	8-Cyl. 90°V OHV	8-Cyl. 90°V OHV	8-Cyl. 90°V OHV
Displacement	240 Cu. In.	302 Cu. In.	351 Cu. In.	390 Cu. In.	429 Cu. In.	429 Cu. In.
Bore and Stroke (Inches)	4.00 x 3.18	4.00 x 3.00	4.00 x 3.50	4.05 x 3.78	4.36 x 3.59	4.36 x 3.59
Compression Ratio	9.2:1	9.5:1	9.5:1	9.5:1	10.5:1	10.5:1
Brake Horsepower @ Specified rpm	150 @ 4000	220 @ 4600	250 @ 4600	265 @ 4400	320 @ 4400	360 @ 4600
Maximum Torque (lb-ft) @ Specified rpm	234 @ 2200	300 @ 2600	355 @ 2600	390 @ 2600	460 @ 2200	480 @ 2800
Valve Lifters	Hydraulic	Hydraulic	Hydraulic	Hydraulic	Hydraulic	Hydraulic
Fuel	Regular	Regular	Regular	Regular	Premium	Premium
Carburetor	Auto. Choke 1V	Auto. Choke 2V	Auto. Choke 2V	Auto. Choke 2V	Auto. Choke 2V	Auto. Choke 4V
Firing Order	1-5-3-6-2-4	1-5-4-2-6-3-7-8	1-3-7-2-6-5-4-8	1-5-4-2-6-3-7-8	1-5-4-2-6-3-7-8	1-5-4-2-6-3-7-8
Spark Plug Type (Autolite No.) and Size	BF-42 (18mm)	BF-42 (18mm)	AF-42 (14mm)	BF-42 (18mm)	BF-42 (18mm)	BF-42 (18mm)
Spark Plug Gap	0.032"-0.036"	0.032"-0.036"	0.032"-0.036"	0.032"-0.036"	0.032"-0.036"	0.032"-0.036"
Distributor						
Point Gap	0.027"	0.021"	0.021"	0.017" (A/T) 0.021" (S/T)	0.021"	0.021"
Point Dwell	35°-40°	24°-29°	24°-29°	26°-31° (A/T) 24°-29° (S/T)	24°-29°	24°-29°
Distributor Diaphragm Type	Dual	Dual	Dual	Single (A/T) Dual (S/T)	Dual	Dual
Idle rpm (1)						
Manual Transmission						
(Without Throttle Solenoid)	—	—	—	—	—	—
(With Throttle Solenoid)	800-500	800-500	750-500	750-500	—	800-500
Automatic Transmission						
(Without Throttle Solenoid)	500	575	600	—	600	600
(With Throttle Solenoid)	500	600-500	600-500	600-500	600-500	600-500
Ignition Timing (BTDC) (2), (3)	6°	6°	6°	6°	6°	6°
Manifold Vacuum (Idle) Minimum "Hg" (4)	15	16	15	17	17	17

ENGINE NOTES:

- Adjust all idle speeds with headlights "ON", automatic transmission in "DRIVE" or manual transmission in "NEUTRAL", and if air conditioner equipped with A/C in "OFF" position. Adjust high idle speed with throttle solenoid operating. Adjust low idle speed with wire disconnected from throttle solenoid.
 - The distributor diaphragm hose or hoses must be disconnected and plugged.
 - If the individual requirements of the vehicle and/or use of sub-standard fuels dictate, the initial timing may have to be retarded from the "normal" setting to eliminate detonation. If retarding is necessary, it should be done progressively and not exceed 2° BTDC.
 - Subtract one inch of mercury from engines equipped with dual diaphragm distributors.
- A/T (Automatic Transmission)
S/T (Synchromesh Transmission)

1970 TORINO

MODELS AND SPECIFICATIONS



MODELS

- FAIRLANE 500 • TORINO • RANCHERO • TORINO GT
- TORINO COBRA • TORINO BROUGHAM • TORINO SQUIRE

SERVICE LOCATIONS

GAS FILLER CAP—Behind Rear License Plate
OIL FILLER CAP—6-Cylinder: Front of Rocker Arm Cover
 —8-Cylinder: Front of Left Rocker Arm Cover
PCV VALVE—6-Cylinder: Rear of Rocker Arm Cover
 —8-Cylinder: Rear of Right Rocker Arm Cover
FUSE PANEL—Behind Lower Edge of Instrument Panel to Left of Steering Column
HOOD LATCH—Top Center of Grille
 To Open: Lift Lever, Raise Hood

IDENTIFICATION

The official Vehicle Identification Number for title and registration purposes is stamped on a tab riveted to the instrument panel close to the windshield on the driver's side of the car and is visible from the outside.

This and other important identifying information is shown on the Vehicle Certification Label that is attached to the rear face of the driver's door. This label is made of a special material and tampering, alteration or removal will result in its destruction or the appearance of the word VOID.

GENERAL DIMENSIONS

Wheelbase		
All models except Station Wagon	117.0"	
Station Wagon	114.0"	
Tread		
Front	60.5"	
Rear	60.0"	
Over-all Length		
All models except Station Wagon	206.2"	
Station Wagon	209.0"	
Over-all Width		
Station Wagon	75.4"	
4-Door Sedan & Hardtop	76.4"	
2-Door Formal Hardtop and Convertible	76.7"	
2-Door Sports Roof Hardtop	76.8"	
Over-all Height		
4-Door Sedan and Hardtop	53.0"	
2-Door Formal Hardtop	52.2"	
2-Door Sports Roof Hardtop	51.0"	
Convertible	52.8"	
Station Wagon	55.9"	

APPROXIMATE REFILL CAPACITIES

(U.S. Measure)

Fuel Tank		
All Models except Ranchero and Station Wagon	22 gal.	
Ranchero	20 gal.	
Station Wagon	19 gal.	
With Evaporative Emission System		
All Models except Ranchero and Station Wagon	20 gal.	
Ranchero	18 gal.	
Station Wagon	17 gal.	
Cooling System (Includes 1 qt. for heater)		
250 CID	11½ qts.	
302 CID	15¼ qts.	
351 CID (with A/C)	15¼ qts.	
351 CID (without A/C)	15½ qts.	
429 CID (except CJ and Boss)	19 qts.	
429 CID CJ and Boss	19½ qts.	
Engine Crankcase (Includes 1 qt. for filter)		
250 CID	4.5 qts.	
302, 351 & 429 CID (except SCJ and Boss)	5 qts.	
429 CID SCJ & Boss (add 1 qt. for Oil Cooler)	7 qts.	
Transmission		
3-Speed Manual	3.5 pts.	
4-Speed Manual	4 pts.	
Cruise-O-Matic		
C-4	9 qts.	
FMX	11 qts.	
C-6	12¼ qts.	
Rear Axle		
250, 302 CID	4 pts.	
351, 429 CID	5 pts.	

LIGHTS (12 VOLTS)

Lamp Description	Candle Power or Wattage	Lamp Number
Standard Equipment		
Headlights		
Hi-Lo Beam	37.5 & 50 Watts	4002
Hi-Beam	37.5 Watts	4001
Front Park/Turn Signal/Side Marker	3-32 c.p.	1157A
Rear Tail/Stop/Turn Signal	3-32 c.p.	1157
Back-up Lamp	32 c.p.	1156
License Plate	4 c.p.	97
Dome Lamp	12 c.p.	105
Hood Mtd. Turn Signals (GT)	2 c.p.	1895
Emergency Flashers	2 c.p.	194
Instrument Panel		
Hi-Beam Indicator	2 c.p.	194
Turn Signal Indicator	2 c.p.	194
Warning Lights	2 c.p.	194
Fuel and Speedometer	2 c.p.	194
Glove Compartment	2 c.p.	1891
Deluxe Seat Belt	2 c.p.	1895
Ash Tray	1.5 c.p.	1445
Heater (or Optional A/C) Bar	2 c.p.	1895
Clock	2 c.p.	1895
Courtesy Lamp (Conv. only)	Fuse Type	562
Accessory Equipment		
Fog Lamps—Clear	35 Watts	4415
Fog Lamp Switch	1 c.p.	53X
Spotlight	30 Watts	4405
Radio Pilot Light	1.9 c.p.	1893
Tachometer	2 c.p.	1895
Auto. Trans. Quadrant	2.0 c.p.	1895
Floor Shift Quadrant	1.5 c.p.	1445
Luggage Compartment	12 c.p.	105
Console Lamp	3 c.p.	1816
Engine Compartment Lamp	6 c.p.	631
Parking Brake Warning	2 c.p.	1895
Map Lamp	6 c.p.	631
Portable Trunk Lamp and Cargo Lamp (S.W.)	15 c.p.	1003
AM/FM (MPX) Radio	1.9 c.p.	1893
A—Amber Color Bulb		

CIRCUIT PROTECTION

Circuit	Location	Rating	Type Fuse or Amperes C.B.*
Headlights	Integral with Light Switch	18	C.B.
Tail Lights, Parking Lights, Side Markers, Headlight Buzzer, License Light and Horns	Integral with Light Switch	15	C.B.
Courtesy, Dome, Map, Cargo, Console, Luggage & Glove Compartment	Fuse Panel	14	SFE
Instrument Panel Lights	Fuse Panel	4	AGA
Emergency Flasher, Cigar Lighter & Clock Feed	Fuse Panel	20	SFE
Warning Lamps (convenience panel), Oil Temp., Dual Brake, Throttle Solenoid, Seat Belt Warning	Fuse Panel	14	SFE
Back-up Lights, Windshield Washer and Radio	Fuse Panel	15	SFE
Spotlight	Fuse Cartridge in Line	7.5	SFE
Heater & Defroster	Fuse Panel	14	AGC
Air Conditioning (R.P.O.)	Fuse Panel	30	AGC
Air Conditioning (Dealer Inst.)	Fuse Panel	20	AGC
Accessory Feed	Fuse Panel	20	AGC
Windshield Wiper	Integral with Wiper Switch	8	C.B.
Power Window, Convertible Top & Station Wagon			
Power Backlite Window	On Starter Relay	20	C.B.
Motors: Windshield Wiper, Power Window, Convertible Top and Power Backlite	Integral with Motor		C.B.

*C.B. Circuit Breaker



1970 TORINO

MODELS AND SPECIFICATIONS

RECOMMENDED TIRE SIZE and INFLATION PRESSURE (cold)

Model	Engine CID Size	Standard Tire		Optional Tire	
		Size (Load Range B)	Pressure Front Rear	Size (Load Range B)	Pressure Front Rear
Sedans, Hardtops, and Fast Backs Fairlane Fairlane GT Torino Torino Brougham	Non AC 250, 302, 351	E78-14	26 28	F78-14	24 26
	AC 250, 302			F70-14 G70-14	28 28
	AC 351	F78-14	27 29	G78-14	24 26
	Non AC 429			F70-14 G70-14	28 28
	AC 429	G78-14	27 29	G70-14	28 28
	Non AC 429 "Cobra"			G70-14 F60-15	28 28
AC 429 "Cobra"	G70-14	28 28	—	—	
2 Dr. Hardtops & Fast Backs	Non AC 429 "Boss"	F60-15	28 28	—	—
	AC 429 "Boss"	G70-14	28 28	—	—
Convertibles	302, 351	F70-14	28 28	G70-14	28 28
	All 429	G70-14	28 28	—	—
Torino G.T.	Non AC 302, 351	E70-14	28 28	F70-14	28 28
	AC 302	F70-14	28 28	G70-14	28 28
	AC 351			G70-14	28 28
Torino G.T. & Cobra	Non AC 429 and 429 "Cobra"	F70-14	28 28	G70-14 F60-15	28 28
	AC 429 "Cobra"			G70-14	28 28
	Non AC 429 "Boss"	F60-15	28 28	—	—
	AC 429 "Boss"	G70-14	28 28	—	—
Station Wagons	ALL	G78-14	22 32	—	—

Model	Full Rated (Maximum) Load					
	Total Load—Occupants Plus Luggage					
	Maximum Load (lbs.)	Total Occupants	Distribution			
Front			Center	Rear	Luggage	
Sedan, Hardtop & Convertible with:						
Bench Seats	1100	6	3	—	3	200 lbs.
Bucket Seats	950	5	2	—	3	200 lbs.
Station Wagons	1200	6	3	3	0	300 lbs.
Station Wagons	1200	8	3	3	2	0

For sustained high speeds or trailer towing—see Owner's Manual

ENGINE SPECIFICATIONS

	250 CID I-6	302 CID V-8 2V	351 CID V-8 2V	351 CID V-8 4V	429 CID 4V	429 CID 4VC & CJ	429 BOSS
Type	In Line 6-Cyl.	8-Cyl. 90°V OHV	8-Cyl. 90°V OHV	8-Cyl. 90°V OHV	8-Cyl. 90°V OHV	8-Cyl. 90°V OHV	8-Cyl. 90°V OHV
Displacement	250 Cu. In.	302 Cu. In.	351 Cu. In.	351 Cu. In.	429 Cu. In.	429 Cu. In.	429 Cu. In.
Bore and Stroke (Inches)	4.00 x 3.91	4.00 x 3.00	4.00 x 3.50	4.00 x 3.50	4.36 x 3.59	4.36 x 3.59	4.36 x 3.59
Compression Ratio	9.0:1	9.5:1	9.5:1	11.4:1	10.5:1	11.0:1	10.5:1
Brake Horsepower @ Specified rpm	155 @ 4000	220 @ 4600	250 @ 4600	300 @ 5400	360 @ 4600	370 @ 5400	375 @ 5200
Maximum Torque (lb.-ft.) @ Specified rpm	240 @ 1600	300 @ 2600	355 @ 2600	380 @ 3400	480 @ 2800	450 @ 3400	490 @ 3400
Valve Lifters	Hydraulic	Hydraulic	Hydraulic	Hydraulic	Hydraulic	Hydraulic	Mechanical
Fuel	Regular	Regular	Regular	Premium	Premium	Premium	Premium
Carburetor	Auto. Choke 1V	Auto. Choke 2V	Auto. Choke 2V	Auto. Choke 4V	Auto. Choke 4V	Auto. Choke 4V	Manual Choke 4V
Firing Order	1-5-3-6-2-4	1-5-4-2-6-3-7-8	1-3-7-2-6-5-4-8	1-3-7-2-6-5-4-8	1-5-4-2-6-3-7-8	1-5-4-2-6-3-7-8	1-5-4-2-6-3-7-8
Spark Plug Type (Autolite No.) and Size	BF-82 (18mm)	BF-42 (18mm)	AF-42 (14mm)	AF-32 (14mm)	BF-42 (18mm)	AF-32 (14mm)	AF-32 (14mm)
Spark Plug Gap	0.032"-0.036"	0.032"-0.036"	0.032"-0.036"	0.032"-0.036"	0.032"-0.036"	0.032"-0.036"	0.032"-0.036"
Distributor							
Point Gap	0.027"	0.021"	0.021"	0.021"	0.021"	0.021"	0.020" dual points
Point Dwell	35°-40°	24°-29°	24°-29°	24°-29°	24°-29°	24°-29°	30°-33°
Distributor Diaphragm Type	Dual	Dual	Dual	Dual	Dual	Dual	Dual
Idle rpm (1)							
Manual Transmission							
(Without Throttle Solenoid)	550	—	—	—	—	700	700
(With Throttle Solenoid)	750-500	800-500	750-500	800-500	800-500	725-500	700-500
Automatic Transmission							
(Without Throttle Solenoid)	—	575	600	600	600	650	—
(With Throttle Solenoid)	600-500	600-500	600-500	600-500	600-500	675-500	—
Ignition Timing (BTDC) (2),(3)	6°	6°	6°	6°	6°	10°	10°
Manifold Vacuum (Idle)							
Minimum "Hg" (4)	18	16	15	15	17	17	17

ENGINE NOTES:

- (1) Adjust all idle speeds with headlights "ON," automatic transmission in "DRIVE" or manual transmission in "NEUTRAL," and if air conditioner equipped, with A/C in "OFF" position. Adjust high idle speed with throttle solenoid operating. Adjust low idle speed with wire disconnected from throttle solenoid.
- (2) The distributor diaphragm hose or hoses must be disconnected and plugged.
- (3) If the individual requirements of the vehicle and/or use of sub-standard fuels dictate, the initial timing may have to be retarded from the "normal" setting to eliminate detonation. If retarding is necessary, it should be done progressively and not exceed 2° BTDC.
- (4) Subtract one inch of mercury for engines equipped with dual diaphragm distributors.

1970 MUSTANG

MODELS AND SPECIFICATIONS



MODELS

- SPORTS ROOF
- HARDTOP
- CONVERTIBLE
- GRANDE
- MACH 1
- BOSS 302
- BOSS 429

IDENTIFICATION

The official Vehicle Identification Number for title and registration purposes is stamped on a tab riveted to the instrument panel close to the windshield on the driver's side of the car and is visible from the outside.

This and other important identifying information is shown on the Vehicle Certification Label that is attached to the rear face of the driver's door. This label is made of a special material and tampering, alteration or removal will result in its destruction or the appearance of the word VOID.

APPROXIMATE REFILL CAPACITIES

(U.S. Measure)

Fuel Tank		
All except Evaporative Emission System	22 gal.	
Evaporative Emission System (Calif. only)	20 gal.	
Cooling System (Includes 1 qt. for heater)		
200 CID	9 qts.	
250 CID	10 qts.	
302 CID (except Boss)	13½ qts.	
302 Boss	15 qts.	
351 CID	14½ qts.	
428 CID	19½ qts.	
429 Boss	18¼ qts.	
Crankcase (Includes 1 qt. for filter)		
6-Cyl. Engines	4.5 qts.	
8-Cyl. Engines (except 429 Boss)	5 qts.	
Boss 429 (add 1 qt. for Oil Cooler)	7 qts.	
Transmission		
3-Speed Manual	3.5 pts.	
4-Speed Manual	4 pts.	
Cruise-O-Matic		
C-4 (200 CID)	8 qts.	
C-4 (250 and 302 CID)	9 qts.	
FMX	11 qts.	
C-6	12¼ qts.	
Rear Axle		
200 CID (2.83:1, 3.08:1 and 3.20:1 ratios)	2.5 pts.	
250 and 302 CID	4 pts.	
351, 428	5 pts.	

CIRCUIT PROTECTION

Circuit	Location	Type Rating Fuse or Amperes C.B.
Headlights	Integral with Light Switch	12 C.B.
Stop, Parking, Rear and License Lamps, Horns, Auto. Trans. Quadrant, and Side Marker	Integral with Light Switch	15 C.B.
Turn Signals, Back up Lamps, Windshield Washer and Radio/Stereo Tape Feed	Fuse Panel	15 SFE
Accessory Feed, Seat Belt Reminder and Parking Brake Warning	Fuse Panel	15 SFE
Heater, Defroster and Rear Window Defogger	Fuse Panel	14 SFE
Instrument Cluster Lamps, Radio, Heater A/C Controls, Clock, Ash Tray Lamp	Fuse Panel	4 SFE
Courtesy, Instrument Door, Dome, Map, Glove Box, "C" Pillar, Luggage Compartment, Clock Feed and Cigar Lighter	Fuse Panel	14 SFE
Emergency Warning & Horn	Fuse Panel	20 SFE
Spare or Carb. Solenoid/Emission Control	Fuse Panel	14 SFE
Windshield Wiper	Integral with Switch	6 C.B.
Convertible Top	Near Starter Relay	20 C.B.
Electrical Motors: Windshield Wiper and Convertible Top	Integral with Motor	C.B.

SERVICE LOCATIONS

- GAS FILLER CAP—Above Rear License Plate
- OIL FILLER CAP—6-Cylinder: Front of Rocker Arm Cover
—8-Cylinder: Front of Left Rocker Arm Cover
- PCV VALVE—6-Cylinder: Rear of Rocker Arm Cover
—8-Cylinder: Rear of Right Rocker Arm Cover
- FUSE PANEL—Behind Lower Edge of Instrument Panel to Right of Steering Column
- HOOD LATCH—Upper Center of Grille
To Open: Pull Lever to Left and Hold, Raise Hood

GENERAL DIMENSIONS

Wheelbase	108.0"
Tread	
Front & Rear (6" Rims)	58.5"
Front & Rear (7" Rims)	59.5"
Over-all Length	187.4"
Over-all Width	71.7"
Over-all Height	
Convertible & Hardtop	51.5"
Sports Roof	50.6"

LIGHTS (12 VOLTS)

Lamp Description	Candle Power or Wattage	Lamp Number
Standard Equipment		
Headlamps—Hi & Lo	40 & 50 Watts	6012
Front Park & Turn Signal	3-32 c.p.	1157NA
Front Side Marker	4 c.p.	97NA
Rear Tail/Stop/Turn Signal	3-32 c.p.	1157
Four-Way Emergency Flashers— Included in Front and Rear Turn Signals		
Back-Up Lamp	3.2 c.p.	1156
License Plate Lamp	4 c.p.	97
Courtesy Lamp—Fastback (63 "C" Pillar)	12 c.p.	105
Courtesy Lamp—Under Inst. Pnl. (63 and 76)	Fuse Type	562
Dome Courtesy (65 only)	12 c.p.	105
Hood Mtd. Turn Signals (Mach 1)	1 c.p.	53X
Rear Side Marker Lamp	2 c.p.	194
Instrument Panel		
Hi-Beam Indicator	2 c.p.	194
Turn Signal Indicators	2 c.p.	194
Turn Signal Indicators are also Emergency Flasher Indicators		
*Warning Lights—Oil, Alt., and Brakes	2 c.p.	194
Glove Compartment Light	2 c.p.	1891
Instruments	2 c.p.	194
Seat Belt Warning Light (R.P.O.)	1.5 c.p.	1445
Heater Control	2 c.p.	1895
Accessory Equipment		
Courtesy Lamp (R.P.O.)	6 c.p.	631
Fog Lamps	35 Watts	4415
Fog Lamp—Switch	1 c.p.	53X
Spotlight 4.4" dia.	30 Watts	4405
R and L Turn Signal Indicators (Outside— in Hood)	1 c.p.	53X
Radio Pilot Light	1.9 c.p.	1893
Warning Light—Brake	1.6 c.p.	256
Safety Conv. Pkg.—Seat Belt	2 c.p.	1891
Auto. Trans. Select	1.5 c.p.	1445
Luggage Compartment Lamp	6 c.p.	631
Engine Compartment Lamp	6 c.p.	631
Portable Trunk Lamp	15 c.p.	1003
Map Lamp	15 c.p.	1004
Clock	2 c.p.	1895
AM/FM (MPX) Radio	1.9 c.p.	1893
Radio AM-Stereo	1.9 c.p.	1893
Reminder Light Belts	2 c.p.	1891
Door Courtesy (R.P.O.)	6 c.p.	212
Floor Console Ash Tray	1.3 c.p.	1892
Ash Tray (Instrument Panel)	1.5 c.p.	1004

NA—Natural Amber Color Bulb
NOTES (*) Oil and Alt. Warning Lights are required with Tach installation only.

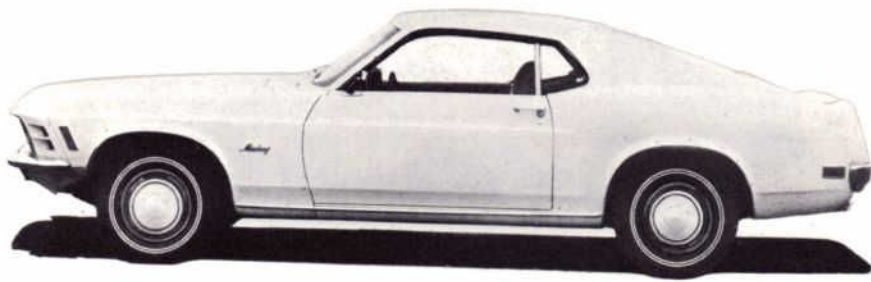

1970 MUSTANG

MODELS AND SPECIFICATIONS

RECOMMENDED TIRE SIZE and INFLATION PRESSURE (cold)

Model	Engine C I D Size	Standard Tire			Optional Tire					
		Size (Load Range B)	Pressure		Size (Load Range B)	Pressure				
			Front	Rear		Front	Rear			
All Except GT Option & Mach I	200	E78-14	24	24	—	—	—			
	250	E78-14	24	24	F70-14	24	24			
	302	E78-14	24	24	F70-14	28	28			
	351									
All Except Competition Package, Mach I & Convertibles	428 Non Ram Air	E70-14	28	28				—	—	—
	428 Ram Air	F70-14	28	28				—	—	—
Convertibles Non AC	428	E70-14	28	28	F70-14	28	28			
Convertibles AC	428	F70-14	28	28	—	—	—			
Competition Package & Mach I	351	E70-14	28	28	F70-14	28	28			
	428	F70-14								
Boss 302	302 Boss	F60-15	26	26	—	—	—			

FULL RATED (MAXIMUM) LOAD					
Models	Total Load—Occupants Plus Luggage				
	Maximum Load (Lbs.)	Total Occupants	Distribution		
			Front	Rear	Luggage
ALL	775	4	2	2	175 LBS

For Sustained High Speeds or Trailer Towing—See Owner's Manual

ENGINE SPECIFICATIONS

	200 CID I-6	250 CID I-6	302 CID V-8 2V	302 BOSS	351 CID V-8 2V	351 CID V-8 4V	428 CID 4V C&J	429 BOSS
Type	In Line 6-Cyl.	In Line 6-Cyl.	8-Cyl. 90°V OHV	8-Cyl. 90°V OHV	8-Cyl. 90°V OHV	8-Cyl. 90°V OHV	8-Cyl. 90°V OHV	8-Cyl. 90°V OHV
Displacement	200 Cu. In.	250 Cu. In.	302 Cu. In.	302 Cu. In.	351 Cu. In.	351 Cu. In.	428 Cu. In.	429 Cu. In.
Bore and Stroke (Inches)	3.68 x 3.13	4.00 x 3.91	4.00 x 3.00	4.00 x 3.00	4.00 x 3.50	4.00 x 3.50	4.13 x 3.98	4.36 x 3.59
Compression Ratio	8.1:1	9.0:1	9.5:1	10.6:1	9.5:1	11.4:1	10.6:1	10.5:1
Brake Horsepower @ Specified rpm.	120 @ 4000	155 @ 4000	220 @ 4600	290 @ 5800	250 @ 4600	300 @ 5400	335 @ 5200	375 @ 5200
Maximum Torque (lb.-ft.) @ Specified rpm.	190 @ 2200	240 @ 1600	300 @ 2600	290 @ 4300	355 @ 2600	380 @ 3400	440 @ 3400	490 @ 3400
Valve Lifters	Hydraulic	Hydraulic	Hydraulic	Mechanical	Hydraulic	Hydraulic	Hydraulic	Mechanical
Fuel	Regular	Regular	Regular	Premium	Regular	Premium	Premium	Premium
Carburetor	Auto. Choke 1V	Auto. Choke 1V	Auto. Choke 2V	Manual Choke 4V	Auto. Choke 2V	Auto. Choke 4V	Auto. Choke 4V	Manual Choke 4V
Firing Order	1-5-3-6-2-4	1-5-3-6-2-4	1-5-4-2-6-3-7-8	1-5-4-2-6-3-7-8	1-3-7-2-6-5-4-8	1-3-7-2-6-5-4-8	1-5-4-2-6-3-7-8	1-5-4-2-6-3-7-8
Spark Plug Type (Autolite No.) and Size	BF-82 (18mm)	BF-82 (18mm)	BF-42 (18mm)	AF-32 (14mm)	AF-42 (14mm)	AF-32 (14mm)	BF-32 (18mm)	AF-32 (14mm)
Spark Plug Gap	0.032"-0.036"	0.032"-0.036"	0.032"-0.036"	0.032"-0.036"	0.032"-0.036"	0.032"-0.036"	0.032"-0.036"	0.032"-0.036"
Distributor Point Gap	0.027"	0.027"	0.021"	0.020" dual points	0.021"	0.021"	0.017" (A/T) 0.020" (S/T) dual points 0.021" (S/T)	0.020" dual points
Point Dwell Angle	35°-40°	35°-40°	24°-29°	30°-33°	24°-29°	24°-29°	26°-31° (A/T) 30°-33° (S/T) dual points 24°-29° (S/T)	30°-33°
Distributor Diaphragm Type	Dual	Dual	Dual	Dual	Dual	Dual	Single (A/T) Dual (S/T)	Dual
Idle rpm (1) Manual Transmission (Without Throttle Solenoid)	750	550	—	—	—	—	725	700
(With Throttle Solenoid)	800-500	750-500	800-500	800-500	750-500	800-500	725-500	700-500
Automatic Transmission (Without Throttle Solenoid)	550	—	575	—	600	600	675	—
(With Throttle Solenoid)	600-500	600-500	600-500	—	600-500	600-500	675-500	—
Ignition Timing (BTDC) (2),(3)	6°	6°	6°	16°	6°	6°	6°	10°
Manifold Vacuum (Idle) Minimum "HG"(4)	17	18	16	16	15	15	15	17

ENGINE NOTES:

- Adjust all idle speeds with headlights "ON", automatic transmission in "DRIVE" or manual transmission in "NEUTRAL", and if air conditioner equipped with A/C in "OFF" position. Adjust high idle speed with throttle solenoid operating. Adjust low idle speed with wire disconnected from throttle solenoid.
 - The distributor diaphragm hose or hoses must be disconnected and plugged.
 - If the individual requirements of the vehicle and/or use of sub-standard fuels dictate, the initial timing may have to be retarded from the "normal" setting to eliminate detonation. If retarding is necessary, it should be done progressively and not exceed 2° BTDC.
 - Subtract one-inch of mercury for engines equipped with dual diaphragm distributors.
- A/T Automatic Transmission.
S/T Synchromesh Transmission.

1970 MAVERICK

MODELS AND SPECIFICATIONS



MODELS

- 2-DOOR SEDAN

IDENTIFICATION

The official Vehicle Identification Number for title and registration purposes is stamped on a metallic tab that is riveted to the instrument panel close to the windshield on the driver's side and is visible from outside of the car.

This number and other important identifying information is shown on the Vehicle Certification Label which is attached to the rear face of the left front door. This label is made of a special material and tampering, alteration or removal will result in its destruction or the appearance of the word VOID.

SERVICE LOCATIONS

GAS FILLER CAP—Center of rear trunk panel, above license plate.

OIL FILLER CAP—Front of rocker arm cover.

PCV VALVE—Rear of rocker arm cover.

FUSE PANEL—On dash panel, to left of steering column.

HOOD LATCH—Top center of grille.

To Open: Lift lever and raise hood. Hold open with support rod.

GENERAL DIMENSIONS

Wheelbase.....	103.0"
Tread	
Front.....	55.5"
Rear.....	55.5"
Height Overall.....	52.3"
Width Overall.....	70.6"
Length Overall.....	179.3"

APPROXIMATE REFILL CAPACITIES

(U.S. Measure)

Fuel Tank	
All except Evaporative Emission System.....	16 gal.
Evaporative Emission System (Calif. only).....	14 gal.
Cooling System (Includes 1 qt. for heater)	
170 CID.....	10 qts.
170 CID with A/C or Extra Cooling.....	10¾ qts.
200 CID.....	9¾ qts.
200 CID with A/C or Extra Cooling.....	10 qts.
Engine Crankcase (Includes 1 qt. for filter).....	4½ qts.
Transmission	
3-Speed Manual.....	3½ pts.
Semi-Automatic.....	8 qts.
Automatic.....	8 qts.
Rear Axle.....	2½ pts.

LIGHTS (12 VOLTS)

Lamp Description	Candle Power or Wattage	Trade Number
Standard Equipment		
Headlamps.....	40-50 watts	6012
Front Park/Turn Signal.....	3-32 c.p.	1157A
Rear Tail/Stop/Turn.....	3-32 c.p.	1157
Back-up Lamp.....	32 c.p.	1156
License Plate Lamp.....	4 c.p.	97
Dome Lamp.....	12 c.p.	105
Front & Rear Side Marker Lamp.....	2 c.p.	194
Instrument Panel		
Hi-Beam Indicator.....	2 c.p.	194
Turn Signal Indicators.....	2 c.p.	194
Warning Lights (Oil, Alt., Hot, Brakes).....	2 c.p.	194
Speedometer & Fuel Gauge.....	2 c.p.	194
Heater Controls.....	2 c.p.	1895
Ash Tray Light.....	1.5 c.p.	1445
Optional Equipment		
Spotlight—4.4" Dia.....	30 watts	4405
Air Cond. Controls.....	2 c.p.	1895
Radio Pilot.....	1.9 c.p.	1893
Auto. Trans. Quadrant.....	1.5 c.p.	1445
Tachometer		
Round.....	2 c.p.	1895
Hood Mounted.....	2 c.p.	57
Luggage Comp.....	6 c.p.	631
Seat Belt Reminder.....	2 c.p.	1895
A—Amber Color Bulb		

CIRCUIT PROTECTION

Circuit	Location	Rating	Type Fuse or Amperes C.B.*
Headlights.....	Integral with Light Switch	12	C.B.
Horn, Stop, Front & Rear Marker, Front Parking, Rear and License Lamps.....	Integral with Light Switch	15	C.B.
Windshield Wiper Circuit.....	Integral with Wiper Switch	6	C.B.
Emergency Flasher, Cigar Lighter and Clock Feed.....	Fuse Panel	20	SFE
Courtesy, Dome, and Luggage Compartment Lamps.....	Fuse Panel	14	SFE
Instruments, Auto. Trans. Quadrant, Ashtray and Radio Lamps.....	Fuse Panel	4	AGA
Heater.....	Fuse Panel	14	SFE
Air Conditioning.....	Fuse Panel	30	SFE
Back Up Lamps, Radio Feed & Windshield Washer.....	Fuse Panel	15	SFE
Accessory Feed and Seat Belt Warning.....	Fuse Panel	20	SFE
Spotlight.....	Cartridge in feed line	7.5	SFE
Motors: Windshield Wiper.....	Integral with motor	—	C.B.

*C.B. Circuit Breaker



1970 MAVERICK

MODELS AND SPECIFICATIONS

RECOMMENDED TIRE SIZE and INFLATION PRESSURE (cold)

Engine CID Size	Standard Tire			Optional Tire		
	Size (Load Range B)	Pressure		Size (Load Range B)	Pressure	
		Front	Rear		Front	Rear
170 & 200	B78-14	24	26	C78-14 D70-14	24	26

FULL RATED (MAXIMUM) LOAD

Model	Total Load—Occupants Plus Luggage				
	Maximum Load (Lbs.)	Total Occupants	Distribution		Luggage
			Front	Rear	
ALL	700	4	2	2	100 Lbs.

For Sustained High Speed or Trailer Towing—See Owner's Manual

ENGINE SPECIFICATIONS

	170 CID I-6	200 CID I-6
Type	In Line 6-Cyl.	In Line 6-Cyl.
Displacement	170 Cu. In.	200 Cu. In.
Bore and Stroke (Inches)	3.50 x 2.94	3.68 x 3.13
Compression Ratio	9.1:1	9.2:1
Brake Horsepower @ Specified rpm	105 @ 4200	120 @ 4000
Maximum Torque (lb-ft) @ Specified rpm	156 @ 2200	190 @ 2200
Valve Lifters	Hydraulic	Hydraulic
Fuel	Regular	Regular
Carburetor	Auto. Choke 1V	Auto. Choke 1V
Firing Order	1-5-3-6-2-4	1-5-3-6-2-4
Spark Plug Type (Autolite No.) and Size	BF-82 (18mm)	BF-82 (18mm)
Spark Plug Gap	0.032"-0.036"	0.032"-0.036"
Distributor		
Point Gap	0.027"	0.027"
Point Dwell Angle	35°-40°	35°-40°
Distributor Diaphragm Type	Dual	Dual
Idle rpm (1)		
Manual Transmission (Without Throttle Solenoid)	750	750
(With Throttle Solenoid)	800-500	800-500
Automatic Transmission (Without Throttle Solenoid)	550	550
(With Throttle Solenoid)	600-500	600-500
Ignition Timing (BTDC) (2), (3)	6°	6°
Manifold Vacuum (Idle) Minimum "Hg" (4)	17	17

ENGINE NOTES:

- (1) Adjust all idle speeds with headlights "ON", automatic transmission in "DRIVE" or manual transmission in "NEUTRAL", and if air conditioner equipped with A/C in "OFF" position. Adjust high idle speed with throttle solenoid operating. Adjust low idle speed with wire disconnected from throttle solenoid.
- (2) The distributor diaphragm hose or hoses must be disconnected and plugged.
- (3) If the individual requirements of the vehicle and/or use of sub-standard fuels dictate, the initial timing may have to be retarded from the "normal" setting to eliminate detonation. If retarding is necessary, it should be done progressively and not exceed 2° BTDC.
- (4) Subtract one inch of mercury for engines equipped with dual diaphragm distributors.

1970 FALCON

MODELS AND SPECIFICATIONS



MODELS

- FALCON 2-DOOR SEDAN
- FALCON 4-DOOR SEDAN
- FALCON STATION WAGON
- FUTURA 2-DOOR SEDAN
- FUTURA 4-DOOR SEDAN
- FUTURA STATION WAGON

IDENTIFICATION

The official Vehicle Identification Number for title and registration purposes is stamped on a tab riveted to the instrument panel close to the windshield on the driver's side of the car and is visible from the outside.

This and other important identifying information is shown on the Vehicle Certification Label that is attached to the rear face of the driver's door. This label is made of a special material and tampering, alteration or removal will result in its destruction or the appearance of the word VOID.

SERVICE LOCATIONS

- GAS FILLER CAP—Left Rear Fender
- OIL FILLER CAP—6-Cylinder: Front of Rocker Arm Cover
—8-Cylinder: Front of Left Rocker Arm Cover
- PCV VALVE—6-Cylinder: Rear of Rocker Arm Cover
—8-Cylinder: Rear of Right Rocker Arm Cover
- FUSE PANEL—Behind Lower Edge of Instrument Panel to Left of Steering Column
- HOOD LATCH—Lower Center of Grille
- To Open: Pull Lever Sideways, Raise Hood

GENERAL DIMENSIONS

Wheelbase	
All models except Station Wagon	111.0"
Station Wagon	113.0"
Tread	
Front	58.8"
Rear	58.5"
Over-all Length	
All models except Station Wagon	184.3"
Station Wagon	198.7"
Over-all Width	73.2"
Over-all Height	
All models except Station Wagon	54.9"
Station Wagon	56.1"

APPROXIMATE REFILL CAPACITIES

(U.S. Measure)

Fuel Tank	
Passenger Car	16 gal.
Station Wagon	19 gal.
With Evaporative Emission System	
Passenger Car	14 gal.
Station Wagon	18 gal.
Cooling System (Includes 1 qt. for heater)	
6-Cylinder	9.5 qts.
8-Cylinder	13.5 qts.
Engine Crankcase (Includes 1 qt. for filter)	
6-Cylinder	4.5 qts.
8-Cylinder	5 qts.
Transmission	
3-Speed Manual	3.5 pts.
Cruise-O-Matic	
C-4 (170 & 200)	8 qts.
C-4 (302)	9 qts.
Rear Axle	
6-Cylinder	2.5 pts.
8-Cylinder	4 pts.

LIGHTS (12 VOLTS)

Lamp Description	Candle Power or Wattage	Lamp Number
Standard Equipment		
Headlights	40-50 Watts	6012
Front Parking & Turn Signal	3-32 c.p.	1157
Rear Tail, Stop and Turn Signal	3-32 c.p.	1157
License Plate	4 c.p.	97
Back-up:		
All models except Station Wagon	32 c.p.	1156
Station Wagon	32 c.p.	1076
Dome	12 c.p.	105
Instrument Panel		
All (Unless otherwise shown)	2 c.p.	194
Heater Controls	2 c.p.	1895
Accessory Equipment		
Cargo	12 c.p.	105
Engine Compartment	6 c.p.	631
Map	6 c.p.	631
Radio	1.9 c.p.	1893
Transmission Quadrant	1.5 c.p.	1445
Courtesy Lamp (Instrument Panel)	6 c.p.	562
Spotlight	30 Watts	4405
Clock	3 c.p.	1816
Tachometer & A/C Controls	2 c.p.	1895
Parking Brake Warning	1.6 c.p.	257
Ashtray	1.5 c.p.	1445
Portable Trunk Lamp	15 c.p.	1003
Luggage Compartment Lamp	12 c.p.	105

CIRCUIT PROTECTION

Circuit	Location	Rating Amperes	Type Fuse or C.B.*
Headlights	Integral with Light Switch	12	C.B.
Tail Lights, Spotlights, Horns, License Light & Parking Light	Integral with Light Switch	15	C.B.
Lights for Dome, Courtesy, Map, Cargo & Luggage Compartment	Fuse Panel	14	SFE
Lights for Instrument Panel & Instrument Cluster	Fuse Panel	4	AGA
Clock Feed, Cigar Lighter & Emergency Warning Flasher	Fuse Panel	20	SFE
Warning Lamps (Convenience Group) Oil, Temp., Dual Brake & Seat Belt	Fuse Panel	14	SFE
Radio, Windshield Washer & Back-up Lights	Fuse Panel	15	SFE
Windshield Wipers	Integral with Wiper Switch	6	C.B.
Power Backlight (Sta. Wag.)	On Starter Relay	20	C.B.
Spotlight	Fuse Cartridge in Line	7.5	SFE
Parking Brake Warning	Fuse Cartridge in Line	4	SFE
Air Conditioner	Fuse Panel	30	SFE
Heater	Fuse Panel	14	SFE
Motors: Wiper & Power Window	Integral with Motor		C.B.

*C.B. Circuit Breaker



1970 FALCON

MODELS AND SPECIFICATIONS

RECOMMENDED TIRE SIZE and INFLATION PRESSURE (cold)

Model	Engine CID Size	Standard Tire			Optional Tire		
		Size (Load Range B)	Pressure		Size (Load Range B)	Pressure	
			Front	Rear		Front	Rear
SEDAN Without Air Conditioning	ALL	6.95-14	26	26	7.35-14	24	24
SEDAN With Air Conditioning	200	6.95-14	26	26			
		302	7.35-14	24	24		
STATION WAGON	ALL	7.75-14	22	32	—	—	—

FULL RATED (MAXIMUM) LOAD

Model	TOTAL LOAD—OCCUPANTS PLUS LUGGAGE					
	Maximum Load (lbs.)	Total Occupants	Distribution			Luggage
			Front	Center	Rear	
SEDANS WITH BENCH SEAT	1075	6	3	—	3	175 lbs.
BUCKET SEAT	925	5	2	—	3	175 lbs.
STATION WAGONS	1200	6	3	3	0	300 lbs.

For Sustained High Speed or Trailer Towing—See Owner's Manual

ENGINE SPECIFICATIONS

	200 CID I-6	302 CID V-8 2V
Type.....	In Line 6-Cyl.	8-Cyl. 90°V OHV
Displacement.....	200 Cu. In.	302 Cu. In.
Bore and Stroke (Inches).....	3.68 x 3.13	4.00 x 3.00
Compression Ratio.....	8.1:1	9.5:1
Brake Horsepower @ Specified rpm.....	120 @ 4000	220 @ 4600
Maximum Torque (lb-ft) @ Specified rpm.....	190 @ 2200	300 @ 2600
Valve Lifters.....	Hydraulic	Hydraulic
Fuel.....	Regular	Regular
Carburetor.....	Auto. Choke IV	Auto. Choke 2V
Firing Order.....	1-5-3-6-2-4	1-5-4-2-6-3-7-8
Spark Plug Type (Autolite No.) and Size.....	BF-82 (18mm)	BF-42 (18mm)
Spark Plug Gap.....	0.032"-0.036"	0.032"-0.036"
Distributor		
Point Gap.....	0.017"	0.021"
Point Dwell.....	35°-40°	24°-29°
Distributor Diaphragm Type.....	Dual	Dual
Idle rpm (1)		
Manual Transmission		
(Without Throttle Solenoid).....	750	—
(With Throttle Solenoid).....	800-500	800-500
Automatic Transmission		
(Without Throttle Solenoid).....	550	575
(With Throttle Solenoid).....	600-500	600-500
Ignition Timing (BTDC) (2), (3).....	6°	6°
Manifold Vacuum (Idle) Minimum "Hg" (4).....	17	16

ENGINE NOTES:

- (1) Adjust all idle speeds with headlights "ON," automatic transmission in "DRIVE" or manual transmission in "NEUTRAL" and if air conditioner equipped, with A/C in "OFF" position. Adjust high idle speed with throttle solenoid operating. Adjust low idle speed with wire disconnected from throttle solenoid.
- (2) The distributor diaphragm hose or hoses must be disconnected and plugged.
- (3) If the individual requirements of the vehicle and/or use of sub-standard fuels dictate, the initial timing may have to be retarded from the "normal" setting to eliminate detonation. If retarding is necessary, it should be done progressively and not exceed 2° BTDC.
- (4) Subtract one inch of mercury for engines equipped with dual diaphragm distributors.

1970 THUNDERBIRD

MODELS AND SPECIFICATIONS



MODELS

- 2-DOOR HARDTOP • 2-DOOR TOWN LANDAU • 4-DOOR LANDAU

IDENTIFICATION

The official Vehicle Identification Number for title and registration purposes is stamped on a tab riveted to the instrument panel close to the windshield on the driver's side of the car and is visible from the outside.

This and other important identifying information is shown on the Vehicle Certification Label that is attached to the rear face of the driver's door. This label is made of a special material and tampering, alteration or removal will result in its destruction or the appearance of the word VOID.

SERVICE LOCATIONS

- GAS FILLER CAP—Left Rear Fender
- OIL FILLER CAP—Front of Left Rocker Arm Cover
- PCV VALVE—Rear of Right Rocker Arm Cover
- FUSE PANEL—Inside of Glove Compartment
- CIRCUIT BREAKER PANEL—R.H. Dash Panel
- HOOD LATCH—Top Center of Grille
- To Open: Pull Lever Out, Raise Hood

LIGHTS (12 VOLTS)

LAMP DESCRIPTION	Candle Power or Wattage	Lamp Number
Standard Equipment		
Headlights		
Hi-Lo Beam.....	37.5 & 50 Watts	4002
Hi-Beam.....	37.5 Watts	4001
Front Park & Turn Signal.....	3-32 c.p.	1157A
Rear Tail/Stop/Turn Signal.....	3-32 c.p.	1157
License Plate.....	4 c.p.	97
"C" Pillar.....	12 c.p.	105
Auto. Trans. Quadrant and Ash Tray.....	1.5 c.p.	1445
Door Courtesy.....	6 c.p.	212
Luggage Compartment.....	6 c.p.	631
Glove Compartment.....	2 c.p.	1895
Back-up Lamps.....	32 c.p.	1156
Front Cornering Lamp.....	50 c.p.	1196
Front Side Marker.....	2 c.p.	194A
Rear Side Marker.....	2 c.p.	194
Instrument Panel		
Glove Compartment.....	2 c.p.	1895
Instrument Panel Courtesy.....	6 c.p.	631
Ash Tray.....	1.5 c.p.	1445
Turn Signal Indicators.....	2 c.p.	168A
Map.....	6 c.p.	212
Brake and Seat Belt Reminder.....	2 c.p.	194
Hi-Beam Indicator.....	2 c.p.	194
Instruments.....	2 c.p.	194
Heater and A/C Controls.....	2 c.p.	1895
Wipers/Washer.....	2 c.p.	194
Accessory Equipment		
Parking Brake Signal.....	2 c.p.	1895
Portable Trunk Lamp.....	15 c.p.	1003
Foglights.....	35 Watts	4415
Foglight Switch.....	1 c.p.	53X
Radio Pilot Light.....	1.9 c.p.	1893
Spotlight.....	30 Watts	4405
Supplemental Parking Lamps.....	6 c.p.	90
High Level Taillamps.....	32 c.p.	1156
Engine Compartment.....	6 c.p.	631
Rear Window Defrost Warning.....	1.3 c.p.	1892
Convenience Control Panel		
Low Fuel.....	2 c.p.	1891
Lights On.....	2 c.p.	1891
Doors Ajar.....	2 c.p.	1891
Seat Belt.....	2 c.p.	1891
A—Amber Color Bulb		

GENERAL DIMENSIONS

Wheelbase	
2-Door Hardtop & Town Landau.....	115.0"
4-Door Landau.....	117.0"
Tread	
Front.....	62.0"
Rear.....	62.0"
Over-all Length	
2-Door.....	212.5"
4-Door.....	215.0"
Over-all Width	
2-Door.....	78.0"
4-Door.....	77.4"
Over-all Height	
2-Door.....	51.4"
4-Door.....	53.6"

APPROXIMATE REFILL CAPACITIES

(U.S. Measure)

Fuel Tank	
All except Evaporative Emission System.....	24 gal.
Evaporative Emission System (Calif. only).....	22½ gal.
Cooling System (Includes 1 qt. for heater).....	20½ qts.
Engine Crankcase (Includes 1 qt. for filter).....	5 qts.
Transmission, Cruise-O-Matic.....	12¾ qts.
Rear Axle.....	5 pts.

CIRCUIT PROTECTION

Circuit	Location	Rating Amperes	Type Fuse or C.B.*
Headlights.....	Integral with Headlight Switch	18	C.B.
Tail, Parking, License, Side Marker & Headlamp Buzzer.....	Integral with Headlight Switch	15	C.B.
Horns, Power Seats, & A/C High Speed Blower.....	C.B. Panel	30	C.B.
Power Windows.....	C.B. Panel	20	C.B.
Rear Window Defroster.....	C.B. Panel	20	C.B.
Cigar Lighter.....	Fuse Panel	20	SFE
Stoptlights & Emergency Warning Flasher.....	C.B. Panel	20	C.B.
Interior Lights: Supplemental Stop Lamp, Map, Clock Feed, Footwell, Courtesy, Glove & Luggage Comp.....	Fuse Panel	20	SFE
Windshield Washer.....	Fuse Panel	10	SFE
Instrument Panel Lights.....	Fuse Panel	6	SFE
Heater, Defroster A/C and Power Window Safety Feed.....	C.B. Panel	30	C.B.
Sure-Track Brake.....	Fuse Panel	3	SFE
Dual Brake Warning.....	Fuse Panel	6	SFE
Radio & Defogger.....	Fuse Panel	7.5	SFE
Turn Signal Flasher and Cornering Lamp.....	Fuse Panel	15	SFE
Speed Control & Back-up Lamps.....	Fuse Panel	7.5	SFE
Power Window Safety Relay Coil Feed and Seat Belt Warning Light (Std.).....	Fuse Panel	15	SFE
Low Fuel, Door Ajar Reminder & Seat Belt Light.....	Fuse Panel	7.5	SFE
Stereo Tape Radio.....	Fuse Panel	15	SFE
SEQUENTIAL TURN SIGNAL FLASHER MOTOR AND RELAY IN LUGGAGE COMPARTMENT			
Motors: Power Window and Seats Integral with Motor			C.B.

*C.B. Circuit Breaker

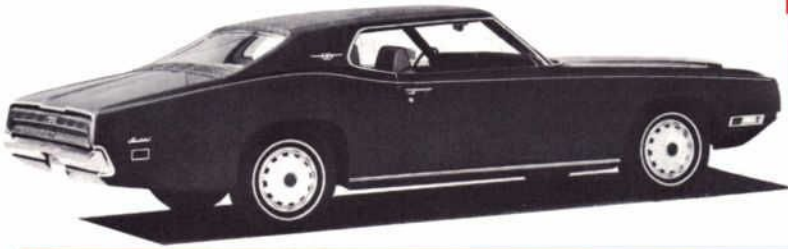

1970 THUNDERBIRD

MODELS AND SPECIFICATIONS

RECOMMENDED TIRE SIZE and INFLATION PRESSURE (cold)

Model	Standard Tire			Optional Tire		
	Size (Load Range B)	Pressure		Size (Load Range B)	Pressure	
		Front	Rear		Front	Rear
All	215-R15 Radial	26	26	8.55-15 H78-15	25 25	25 25
FULL RATED (MAXIMUM) LOAD						
Model	Maximum Load (lbs.)	Total Occupants	Distribution			
			Front	Rear	Luggage	
Tudor with Bucket Seats	750	4	2	2	150 lbs.	
Bench Seats	900	5	3	2	150 lbs.	
Fordor with Bucket Seats	900	5	2	3	150 lbs.	
Bench Seats	1050	6	3	3	150 lbs.	
For sustained high speeds or trailer towing—see Owner's Manual.						

ENGINE SPECIFICATIONS

Type.....	429 CID V-8 4V
Displacement.....	8-Cyl. 90° V OHV
Bore and Stroke (Inches).....	429 Cu. In.
Compression Ratio.....	4.36 x 3.59
Brake Horsepower @ Specified rpm.....	10.5:1
Maximum Torque (lb.-ft.) @ Specified rpm.....	360 @ 4600
Valve Lifters.....	480 @ 2800
Fuel.....	Hydraulic
Carburetor.....	Premium
Firing Order.....	Auto. Choke 4V
Spare Plug Type (Autolite No.) and Size.....	1-5-4-2-6-3-7-8
Spark Plug Gap.....	BRF-42 (18mm)
Distributor.....	0.032"-0.036"
Point Gap.....	0.021"
Point Dwell.....	24°-29°
Distributor Diaphragm Type.....	Dual
Idle rpm (1)	
Automatic Transmission	
(without Throttle Solenoid).....	600
(with Throttle Solenoid).....	600-500
Ignition Timing (BTDC) (2)(3).....	6°
Manifold Vacuum (Idle) Minimum "Hg" (4).....	17

ENGINE NOTES³

- (1) Adjust all idle speeds with headlights "ON," automatic transmission in "DRIVE," and if air conditioner equipped, with A/C in "OFF" position. Adjust high idle speed with throttle solenoid operating. Adjust low idle speed with wire disconnected from throttle solenoid.
- (2) The distributor diaphragm hose or hoses must be disconnected and plugged.
- (3) If the individual requirements of the vehicle and/or use of sub-standard fuels dictate, the initial timing may have to be retarded from the "normal" setting to eliminate detonation. If retarding is necessary, it should be done progressively and not exceed 2° BTDC.
- (4) Subtract one-inch of mercury for engines equipped with dual diaphragm distributors.

BRONCO



1970 Models &

IDENTIFICATION

The car warranty number and other important identifying information is stamped on the rating plate which is attached to the inside of the glove box door.

The official Vehicle Identification Number for title and registration purposes is located on top of the right front frame rail approximately 12 inches behind the shock absorber. Do not use warranty plate information for license or title identification.

This and other important identifying information is shown on the Vehicle Certification Label that is attached to the rear face of the driver's door. This label is made of a special material and tampering, alteration or removal will result in its destruction or the appearance of the word VOID.

GENERAL DIMENSIONS

Wheelbase.....	92"
Tread:	
Front.....	57.4"
Rear.....	57.4"
Over-all Length.....	152.1"
Over-all Width.....	68.8"
Over-all Height (Pickup).....	68.2"
(Wagon).....	71.4"

APPROXIMATE REFILL CAPACITIES

(U.S. Measure)		
Fuel Tank		
All except California.....	14½ gals.	
California Registration Only.....	11½ gals.	
Fuel Tank (Auxiliary)		
All except California.....	11½ gals.	
California Registration Only.....	8½ gals.	
Cooling System (Includes 1 qt. for heater)		
170 CID Six.....	10 qts.	
302 CID V-8.....	16 qts.	
Crankcase (Includes 1 qt. for filter)		
170 CID Six.....	7 qts.	
302 CID V-8.....	6 qts.	
Transmission:		
3-Speed Manual.....	3½ pts.	
Front Axle.....	4 pts.	
Rear Axle.....	9 pts.	
Transfer Case.....	2½ pts.	
Oil Bath Air Cleaner.....	1 pt.	

LIGHTS (12 VOLTS)

Lamp Description	Candle Power or Wattage	Lamp Number
Headlights.....	40-50 Watts	6012
Front Park and Turn Signal.....	3-32 c.p.	1157
Rear Tail, Stop and Turn Signal.....	3-32 c.p.	1157
License Plate.....	4 c.p.	1178
Back-Up Lamp.....	32 c.p.	1156
Map (R.P.O.).....	6 c.p.	631
All Instrument Panel Lights.....	2 c.p.	1895
Radio Pilot.....	2 c.p.	1895
Warning Brakes.....	2 c.p.	1895
Engine Compartment.....	6 c.p.	631
Portable Trunk.....	15 c.p.	1003
Front and Rear Side Marker.....	1 c.p.	161

LOAD CAPACITIES AND INFLATION PRESSURES

Model Code Inflation	Maximum Gross Vehicle Weight (Pounds)	Minimum Optional Equipment Req'd. for Warranty at Indicated Max. Gross Vehicle Wt.	Tire Size and Type	Recommended Cold Inflation Pressure	
				Front	Rear
U-140 (Pick-up)	3900 lb. ①	—	⑦7.35 x 15-B-PT	30	30
U-150 (Wagon)			⑦7.75 x 15-B-PT		
			⑦6.78 x 15-B-PT		
U-142 (Pick-up)	4700 lb. ②	3300 lb. Rear Axle, 1280 lb. Rear Springs	8.25 x 15-D-PT	30	32/U-142 30/Others
U-152 (Wagon)			③9.15 x 15-B-PT	30	30
			③⑥6.50 x 16-6PR-TT	35	45/U-142 35/Others

① Standard GVW Rating ② Optional GVW Rating Plate ③ Optional Tires
 ④ Tube Type PT—Passenger Type TT—Truck Type B—Load Range B replaces 4-ply rating D—Load Range D replaces 8-ply rating

ON FOUR-WHEEL DRIVE VEHICLES ALL TIRES MUST BE OF EQUAL SIZE AND PLY RATING

SERVICE LOCATIONS

GAS FILLER CAP LOCATION—Left Rear Quarter Panel
 HOOD LATCH LOCATION—Center of Grille
 To Open: Pull Out Hood Release Lever. Press Up on Safety Catch (Top Center of Grille) and Open Hood. Hold Open with Support Rod.
 OIL FILLER CAP—6-Cylinder: Front of Rocker Arm Cover
 —8-Cylinder: Front of Left Rocker Arm Cover
 PCV VALVE—6-Cylinder: Rear of Rocker Arm Cover
 —8-Cylinder: Rear of Right Rocker Arm Cover
 FUSE PANEL—Under Center of Instrument Panel

CIRCUIT PROTECTION

Circuit	Location	Rating Amperes	Type Fuse or C.B.*
Headlights.....	Integral with Light Switch	12	C.B.
Stop Lights, Tail Lights, Parking Lights, License Light and Horns.....	Integral with Light Switch	15	C.B.
Heater and Defroster.....	Fuse Panel	20	SFE
Instrument Panel Lamps.....	Fuse Panel	2	AGA
Emergency Warning Flasher.....	Fuse Panel	20	AGX
Turn Signal and Backup Lights, Radio and Windshield Washers.....	Fuse Panel	14	SFE
Cigar Lighter and Dome Lamp.....	Fuse Panel	15	AGW

*C.B. Circuit Breaker

ENGINE SPECIFICATIONS

	170 CID I-6	302 CID V-8 2V
Type.....	In Line 6-Cyl.	8-Cyl. 90°V OHV
Displacement.....	170 Cu. In.	302 Cu. In.
Bore and Stroke (Inches).....	3.50 x 2.94	4.00 x 3.00
Compression Ratio.....	9.1:1	9.5:1
Brake Horsepower @ Specified rpm.....	105 @ 4400	220 @ 4600
Maximum Torque (lb-ft) @ Specified rpm.....	158 @ 2400	300 @ 2600
Valve Lifters.....	Hydraulic	Hydraulic
Fuel.....	Regular	Regular
Carburetor.....	Auto. Choke IV	Auto. Choke 2V
Firing Order.....	1-5-3-6-2-4	1-5-4-2-6-3-7-8
Spark Plug Type (Autolite No.) and Size.....	BF-82 (18mm)	BF-42 (18mm)
Spark Plug Gap.....	0.032"-0.036"	0.032"-0.036"
Distributor		
Point Gap.....	0.027"	0.021"
Point Dwell Angle.....	35°-40°	24°-29°
Distributor Diaphragm Type.....	Dual	Dual
Idle rpm (1)		
Manual Transmission		
(Without Throttle Solenoid).....	775	675
(With Throttle Solenoid).....	800-500	800-500
Ignition Timing (BTDC) (2), (3).....	6°	6°
Manifold Vacuum (Idle) Minimum "Hg" (4).....	17	16

ENGINE NOTES:

- Adjust all idle speeds with headlights "ON" and manual transmission in "NEUTRAL." Adjust high idle speed with throttle solenoid operating. Adjust low idle speed with wire disconnected from throttle solenoid.
- The distributor diaphragm hose or hoses must be disconnected and plugged.
- If the individual requirements of the vehicle and/or use of sub-standard fuels dictate, the initial timing may have to be retarded from the "normal" setting to eliminate detonation. If retarding is necessary, it should be done progressively and not exceed 2° BTDC.
- Subtract one inch of mercury for engines equipped with dual diaphragm distributors.

SHOCK ABSORBERS (Autolite Sales No.)

	Auto-Flex	Auto-Flex XD	Super-Flex
Front	AB-117	AX-122	—
Rear	AB-103	AX-125	AA-133

Specifications



ECONOLINE

MODELS

- CLUB WAGON BUS
- ECONOLINE WINDOW VAN
- ECONOLINE VAN
- ECONOLINE DISPLAY VAN

IDENTIFICATION

The vehicle warranty number is stamped on the warranty plate, which is attached to the rear face of the left front door lock panel.

The official Vehicle Identification Number for title and registration purposes is stamped on the inboard face of the alternator regulator bracket.

GENERAL DIMENSIONS

Wheelbase	
Regular Van	105.5"
SuperVan	123.5"
Over-all Length	
Regular Van	169.1"
SuperVan	187.1"
Unobstructed Floor Dimensions	
Width between wheelhousings	53.5"
Length behind driver:	
Regular Van	103.7"
SuperVan	121.7"

APPROXIMATE REFILL CAPACITIES

(U.S. Measure)

Fuel Tank:	
All except California	24 gals.
All built for California Registration	21 gals.
Cooling System (Includes 1 qt. for Heater)	
170 Six—Std. and Extra Cooling	9¼ qts.
240 Six—Std. and Extra Cooling	14½ qts.
With A/C	16¼ qts.
302 V-8—Std. and Extra Cooling with manual transmission	15¼ qts.
With A/C or Extra Cooling with automatic transmission	17½ qts.
Engine Crankcase (Includes 1 qt. for filter)	
170 CID	4½ qts.
240 & 302 CID	5 qts.
Transmission	
3-Speed Manual	3½ qts.
SelectShift Cruise-O-Matic	10¼ qts.
Rear Axle	
Standard, Heavy Duty and Limited Slip	6 pts.

LIGHTS (12 VOLTS)

Lamp Description	Candle Power or Wattage	Lamp Number
Cigar Lighter	1.5 c.p.	1445
Alternator Indicator	2 c.p.	1895
Dual Brake Warning	2 c.p.	1895
Back-Up Lamp	32 c.p.	1156
Side Marker	2 c.p.	194
Headlight	50-40 watts	6012
High Beam Indicator	2 c.p.	1895
Interior, Dome and Cargo	15 c.p.	1003
Turn Signal Indicator	2 c.p.	1895
Oil Pressure Indicator	2 c.p.	1895
Parking and Front Turn Indicator	3-32 c.p.	1157
Radio Dial	1.9 c.p.	1891
Rear License Plate	4 c.p.	97 or 1155
Speedometer and Odometer	2 c.p.	1895
Spotlight	30 watts	4405
Stop, Tail, and Rear Turn Indicator	3-32 c.p.	1157
Seat Belt Reminder	2 c.p.	1895
Fog Lamps	35 watts	4415A
Fog Lamp Switch	1.5 c.p.	53X
Clock	2 c.p.	1895
School Bus Warning Lamps	75 watts	4633R
A—Amber Color Bulb		

FUSES AND CIRCUIT BREAKERS

	LOCATION	CIRCUIT PROTECTION	FUSE NO.
Headlamps	Integral with light switch	12 amp. C.B.	—
Tail, License and Parking Lamps and Horns	Integral with light switch	15 amp. C.B.	—
Turn Signal, Back-up Lamps and Windshield Washer Circuits	Fuse panel—on engine side panel. L.H. side under instrument panel.	14 amp. Fuse	SFE 14
Emergency Warning and Stoplamp Circuits	Fuse panel—on engine side panel. L.H. side under instrument panel.	20 amp. Fuse	AGX 20
Cigar Lighter, Dome Lamp and Cargo Lamp	Fuse panel—on engine side panel. L.H. side under instrument panel.	15 amp. Fuse	AGW 15
Heater and Defroster	Fuse panel—on engine side panel. L.H. side under instrument panel.	20 amp. Fuse	AGC or SFE 20

FUSES AND CIRCUIT BREAKERS (Continued)

	LOCATION	CIRCUIT PROTECTION	FUSE NO.
Instrument Panel Lamps	Fuse panel—on engine side panel. L.H. side under instrument panel.	2 amp. Fuse	AGA 2
Spotlight	Cartridge in feed line	7.5 amp. Fuse	SFE-7.5
Radio	Cartridge in feed line	5.0 amp. Fuse	AGA 5
Windshield Wiper System	Integral with wiper switch	C.B.	—
Fog Lamps	Cartridge in feed line	10 amp.	AGC 10
Auxiliary Heater	Cartridge in feed line	14 amp. Fuse	SFE 14
Ammeter (8 Cyl.)	Cartridge in feed line	4 amp.	SFE 4
Air Conditioner	Cartridge in feed line	30 amp.	—
School Bus Warning Lamps	On starter motor relay	20 amp. C.B.	—

ENGINE SPECIFICATIONS

	170 CID I-6	240 CID I-6	302 CID V-8 2V
Type	In Line 6-Cyl.	In line 6-Cyl.	8-Cyl. 90°V OHV
Displacement	170 Cu. In.	240 Cu. In.	302 Cu. In.
Bore and Stroke (Inches)	3.50 x 2.94	4.00 x 3.18	4.00 x 3.00
Compression Ratio	9.1:1	9.2:1	9.5:1
Brake Horsepower @ Specified rpm	105 @ 4400	150 @ 4000	220 @ 4600
Maximum Torque (lb-ft) @ Specified rpm	158 @ 2400	234 @ 2200	300 @ 2600
Valve Lifters	Hydraulic	Hydraulic	Hydraulic
Fuel	Regular	Regular	Regular
Carburetor	Auto. Choke 1V	Auto. Choke 1V	Auto. Choke 2V
Firing Order	1-5-3-6-2-4	1-5-3-6-2-4	1-5-4-2-6-3-7-8
Spark Plug Type (Autolite No.) and Size	BF-82 (18mm)	BTF-6 (18mm)	BF-42 (18mm)
Spark Plug Gap	0.032"-0.036"	0.032"-0.036"	0.032"-0.036"
Distributor			
Point Gap	0.027"	0.027"	0.021"
Point Dwell Angle	35°-40°	35°-40°	24°-29°
Distributor Diaphragm Type	Dual	Dual	Dual
Idle rpm (1)			
Manual Transmission			
(Without Throttle Solenoid)	775		675
(With Throttle Solenoid)	800-500	850-500	800-500
Automatic Transmission			
(Without Throttle Solenoid)		500	600
(With Throttle Solenoid)		575-500	600-500
Ignition Timing (BTDC) (2), (3)	6°	6°	6°
Manifold Vacuum (Idle)			
Minimum "Hg" (4)	17	15	16

ENGINE NOTES

(1) Adjust all idle speeds with headlights "ON," automatic transmission in "DRIVE" or manual transmission in "NEUTRAL," and if air conditioner equipped, with A/C in "OFF" position. Adjust high idle speed with throttle solenoid operating. Adjust low idle speed with wire disconnected from throttle solenoid. (2) The distributor diaphragm hose or hoses must be disconnected and plugged. (3) If the individual requirements of the vehicle and/or use of sub-standard fuels dictate, the initial timing may have to be retarded from the "normal" setting to eliminate detonation. If retarding is necessary it should be done progressively and not exceed 2°BTDC. (4) Subtract one inch of mercury for engines equipped with dual diaphragm distributors.

SHOCK ABSORBERS (Autolite Sales No.)

	Auto-Flex	Auto-Flex XD	Super-Flex
FRONT	AB-137	AX-114*	N. A.
REAR	AB-138	AX-109*	AA-113*

*Except 170 and 302-CID

FORD TRUCKS

1970 Models &

Ford F-100



Ford F-250



Ford F-350



Ford Parcel Delivery



GASOLINE ENGINES

Engine	240 CID	300 CID	302 CID	360 CID	390 CID
Bore (Inches)	4.00	4.00	4.00	4.05	4.05
Stroke (Inches)	3.18	3.98	3.00	3.50	3.786
Taxable (SAE) Horsepower	38.4	38.4	51.2	52.5	52.5
Compression Ratio	9.2:1	8.8:1	8.6:1	8.4:1	8.6:1
Engine Idle Speed (rpm) ①	500/850	775/500	800/500	650/500	650/500
Standard Transm. ②	③				
Over 6000 GVW (Calif.)	600	—	—	—	—
Automatic Transm. ② ③	500/575	500/550	600/500	600/500	550/500
Over 6000 GVW (Calif.)	550	550	—	—	—
Cylinder Firing Order	1-5-3-6-2-4			1-5-4-2-6-3-7-8	
Spark Plug Number (Autolite)	BTF-42	BTF-42	BTF-31	BF-32	BF-32
Spark Plug Gap	0.032-0.036		0.028-0.032	0.032	0.036
Distributor Point Gap					
Exhaust Emission	0.027	0.027	0.021†	0.021	0.021
Non-Exhaust Emission	0.025	0.025	—	0.017	0.017
Ignition Timing—° BTC ①	6°	6°	6°	6°	6°

① If the individual requirements of the vehicle and/or use of sub-standard fuels dictate, the initial timing may have to be retarded from the "Normal" setting to eliminate detonation. If retarding is necessary it should be done progressively and not to exceed 2° B.T.D.C.

② With headlights ON ③ Transmission in drive

④ Idle speed with throttle activator energized

† 0.021 inch with dual diaphragm distributor

FORD DIESEL ENGINE

Engine	4-Cylinder 242
Bore (inches)	4.125
Stroke (inches)	4.52
Displacement (cubic inches)	242
Taxable (SAE) Horsepower	27.2
Horsepower @ rpm—Net	74 @ 2800
Gross	82.5 @ 2800
Maximum Torque (ft. lb. @ rpm)—Net	186 @ 1700
Gross	186 @ 1700
Compression Ratio	16.5 to 1
Compression Pressure	363 psi @ 215
Maximum Engine rpm (No Load)	3090
(Loaded)	2800
Idle Speed (rpm @ Neutral) Hot	500-550
Valve Lash Hot (inches)—Intake	.015
—Exhaust	.012
Oil Pressure Hot (psi)	45-55
Cylinder Firing Order	1-2-4-3
Air Cleaner—Type	Oil Bath
Injection System	
Injector Nozzle Opening Pressure psi	2600-2700 psi
Injector Pump Timing	22° BTDC
Belt Tension (New)	140 lbs.
(Reset—After 10 min. operation)	110 lbs.

Specifications

100 THRU 350, AND P SERIES

FORD TRUCKS

APPROXIMATE REFILL CAPACITIES

(U.S. Measure)

COOLING

Engine	Truck Model	Approx. Capacity* (Quarts) U.S. Measure
240	F-100-250—4 x 2 (Manual Transmission) (Automatic Transmission) W/Air Conditioning	13 14½ 17
240	F-100-250—4 x 4, F-350 Single Rim Rear Wheels W/Air Conditioning	12 18¼
240	F-350 Single Rim Rear Wheels (Automatic Transmission)	14½
240	F-350 Dual Rear Wheels W/Air Conditioning	17 18¼
240	P-350-400-500	17
300	F-100-250—4 x 2, F-100-250—4 x 4, F-350 Single Rim Rear Wheels W/Air Conditioning	14½ 17
300	F-350 Single Rim Rear Wheels (Automatic Transmission) W/Air Conditioning	17 18¼
300	F-350 Dual Rear Wheels W/Air Conditioning	17 18¼
300	P-350-400-500	18
302 360	F-100-250—4 x 2 W/Air Conditioning	22 22¼
360	F-100-200—4 x 4, F-350 Single Rim Rear Wheels, F-350 Dual Rear Wheels W/Air Conditioning	22¼ 24
390	F-100-250—4 x 2	22¼
390	F-350 Single Rim Rear Wheels, F-350 Dual Rear Wheels W/Air Conditioning	22¼ 24

*Includes 1 quart for trucks equipped with heater.

CRANKCASE

Engine	Quarts*
240 Six	4
240 Six (4 x 4, F-350 and P-Series)	5
300, 302, 360 and 390 C I D	5

*Add 1 Quart with filter change.

REAR AXLE

Rear Axle Model	Truck Model	Pints
Ford 3300	F-100, P-100	6½
Dana 44F (front axle)	4-Wheel Drive (F-100, F-250)	3¼ *
Dana 44F HD (front axle)	4-Wheel Drive (F-250)	3¼ *
Dana 60-3	F-100	6
Dana 60	F-250, P-350, P-3500	6
Dana 70	F-350, P-350, P-3500, P-400, P-4000	6
Rockwell C-100-N	P-500, P-5000	13
Rockwell D-100-N	P-500	13

*Add 1 pint for each steering knuckle.

FUEL TANK

Tank Type	Truck Model F-100-350 And P-Series	Gallons
Standard	F-Series (cab models) Except Calif. Reg. F-100 (California registration Cab Models)	20 18½
	F-100, 250 Chassis windshield, P-Series Chassis, F-350 Series Cowl or Chassis windshield models	17
Optional (Outside of Frame)	P-350, P-400 and P-500	30
Optional (Under Cab)	F-100/F-350 (Except Calif. Reg.) California Registration Only	24 22

TRANSMISSION

Transmission Type and Make	Pints
3-Speed (Ford)	3½
3-Speed w/Overdrive (Warner T-85-N)	4
3-Speed Medium Duty (Warner T-89-F)	3¼
3-Speed Heavy Duty (Warner T-87-G)	5½
4-Speed (Warner T-18)	6½
4-Speed (New Process 435)	6½
HD Cruise-O-Matic	22
C-4 Automatic	20½
C-6 Automatic	25½
4-Wheel Drive Transfer Case Single Speed F-100	1¼
4-Wheel Drive Transfer Case 2-Speed F-250	4½

CIRCUIT PROTECTION

Circuit	F-100-350	P-Series
Tail, Park, License, Marker and Stop Lights		12 amp. C.B. ②
Tail, Park, License, Marker Lights and Horn	15 amp. C.B. ②	
Dome, Courtesy, Map, Cargo Lights and Cigar Lighter	Models 81, 85 AGW 15 Fuse ① Model 84	SFE or AGW 7.5 Fuse
Turn Signal, Backup Lights and W/S Washer (F-Series Only)	SFE-14 Fuse ①	AGC-10 Fuse ④
W/S Washer Pump	Integral C.B.	AGC-10 Fuse ④
Instrument Panel Lights	AGA-2 Fuse ①	AGA-1 Fuse ④
Emergency Warning and Stop (F-Series Only) Lights	AGX-20 Fuse ①	SFE-14 Fuse ④
Headlights	12 amp. C.B. ②	12 amp. C.B. ②
Heater	AGC or SFE-20 Fuse ①	SFE-14 Fuse ④
W/S Wiper	C.B. ②	C.B. ②
Roof Marker Lamps F-350 Stake Platform or Dual Wheels	Camper Special Option 15 amp. C.B. 25 amp. C.B.	
Charging and Gauge Circuit	Fuse Link ④	
Overdrive Transmission	AGC-15 Fuse ②	
Fuel System (Dorset Diesel)		6 amp. C.B.

- ① Fuse Panel
② Integral with Headlamp Switch
③ Clip on O.D. Relay
④ Cartridge in Feed Wire
⑤ Integral with Switch

NOTE: DO NOT exceed 8.5 amp. load across ignition switch for rear light circuit on trucks or buses with hydraulic stop light switch.

LIGHTS (12 VOLTS)

Description	Candle Power or Wattage	Lamp Number
Cigarette Lighter Socket	1.5 c.p.	1445
Dome Light	1.5 c.p.	1004
Front Parking Only	4 c.p.	97
Front Turn Signal/Parking	32-3 c.p.	1157
Heater Control	2 c.p.	1895
Alternator Indicator	2 c.p.	1895
Headlights Single—High/Low Beam	50/40 Watts	6012
Instrument Cluster Illumination	2 c.p.	1895
Instrument Panel Indicators—Hi-Beam	2 c.p.	1895
Marker	4 c.p.	97
Oil Pressure	2 c.p.	1895
Radio Dial	2 c.p.	1895
Rear License Light Only	4 c.p.	97
Rear Turn Signal & Stop/Tail	32-3 c.p.	1157
Spotlight Par 46	30 Watts	4435
Spotlight Par 36	30 Watts	4405
Rear or Front Turn Signal only	32 c.p.	1156
Fog Lights, Amber	35 Watts	4415A
Fog Light Switch	1 c.p.	53X
Turn Signal Indicator	2 c.p.	1895
Brake Warning Light	1.5 c.p.	1445

ENGINES (GAS)

	300LD-6	300HD-6	330MD V-8	330HD V-8	361 V-8	391 V-8	401 V-8	477 V-8	534 V-8
Bore (inches)	4.000	4.000	3.875	3.875	4.050	4.050	4.125	4.500	4.500
Stroke (inches)	3.980	3.980	3.500	3.500	3.500	3.786	3.750	3.750	4.200
Taxable Horsepower	38.40	38.40	48.05	48.05	52.49	52.49	54.00	65.00	65.00
Brake Horsepower @ Special rpm	170 @ 3600	170 @ 3600	190 @ 4000	190 @ 4000	210 @ 4000	235 @ 4000	226 @ 3600 (4V)	253 @ 3400 (4V)	266 @ 3200 (4V)
Engine Governed rpm									
Manual Transmission (load)	3600	3600	3600	3600	3600	3600	3400	3200	3000
Auto. Transmission (load)	3800	3800	3900	3800	3800	3800	25-3400	25-3400	25-3200
Manual Transmission (no-load)	3600	3600	3600	3600	3600	3600	3600	3400	3200
Auto. Transmission (no-load)	3800	3800	3900	3900	3800	3800	3800	3600	3400
Max. Gross Torque lb.-ft. @ rpm	283 @ 14-2400	283 @ 14-2400	305 @ 2000	306 @ 2000	345 @ 2000	372 @ 2000	343 @ 20-2600	415 @ 20-2600	481 @ 16-1800
Compression Ratio	8.8:1	8.8:1	7.4:1	7.4:1	7.4:1	7.4:1	7.5:1	7.5:1	7.5:1
Compression Pressure psi @ Cranking Speed	150-200	150-200	120-160	120-160	120-160	120-160	130-170	130-170	130-170
Idle Speed rpm (with lights on) (1)									
Manual Transmission	500		550	550	550	550	550	550	550
Automatic Transmission—(In Drive)	600	600	550	550	550	550	550	550	550
Ignition Timing (BTDC) (2) (3)									
Manual Transmission	6°	6°	12°	6°	6°	6°	8°	8°	8°
Automatic Transmission	6°	6°	—	6°	6°	6°	8°	8°	8°
Oil Pressure—Hot psi @ 2000 rpm	35-60	35-60	35-60	35-60	35-60	35-60	35-60	35-60	35-60
Oil Capacity (qts.) (add 1 qt. for filter) *(Add 2 qt. for filter)	5	6	8	8	8	8	9*	9*	9*
Firing Order	1-5-3-6-2-4	1-5-3-6-2-4	1-5-4-2-6-3-7-8	1-5-4-2-6-3-7-8	1-5-4-2-6-3-7-8	1-5-4-2-6-3-7-8	1-5-4-8-6-3-7-2	1-5-4-8-6-3-7-2	1-5-4-8-6-3-7-2
Distributor Point Gap—Conventional	0.025	0.025	0.017	0.017	0.017	0.017	0.017	0.017	0.017
Transistorized Dist.—Point Gap (inches)	0.027	0.027	0.020	0.020	0.020	0.020	0.020	0.020	0.020
Spark Plug Gap (inches)	0.032 0.036	0.028 0.032	0.028 0.032	0.028 0.032	0.028 0.032	0.028 0.032	0.028 0.032	0.028 0.032	0.028 0.032
Spark Plug	BTF-42	BTF-42	BTF-31	BTF-31	BTF-31	BTF-31	BTF-31	BTF-31	BTF-31

ENGINES (DIESEL)

	Ford 363	C-160	CF-160	C-180	NHE-195	NH-220	NHC-250	NTC-335	V8E-235	V8-265	6V-53N	1673
Bore (inches)	4.125	4.438	4.438	4.438	5.125	5.125	5.500	5.500	5.500	5.500	3.870	4.500
Stroke (inches)	4.516	5.000	5.000	5.000	6.000	6.000	6.000	6.000	4.125	4.125	4.500	5.500
Brake Horsepower @ rpm	128 @ 2800	160 @ 2500	160 @ 2800	180 @ 2500	195 @ 1950	220 @ 2100	250 @ 2100	335 @ 2100	235 @ 2100	265 @ 2600	195 @ 2600	225 @ 2200
Engine Governed rpm	3090 NL 3800 FL	2500	2800	2500	1950	2100	2100	2100	2100	2600	2600	2200
Maximum Gross Torque lb.-ft. @ rpm	254 @ 1400	376 @ 1400	345 @ 1800	425 @ 1700	580 @ 1300	606 @ 1600	685 @ 1500	895 @ 1500	576 @ 1600	600 @ 1800	446 @ 1500	605 @ 1700
Compression Ratio	16.0:1	15.8:1	15.8:1	14.5:1	15.0:1	15.0:1	15.0:1	14.1:1	17.0:1	17.0:1	21.0:1	18.0:1*
Compression Pressure psi @ Cranking Speed	365	365	365	365	365	365	365	365	365	365		
Idle Speed rpm	525	520	520	520	520	520	520	520	520	520		
Displacement (cu. in.)	363	464	464	464	743	743	855	855	785	785	318	525
Firing Order	1-5-3-6-2-4	1-5-3-6-2-4	1-5-3-6-2-4	1-5-3-6-2-4	1-5-3-6-2-4	1-5-3-6-2-4	1-5-3-6-2-4	1-5-3-6-2-4	1-5-4-8-6-3-7-2	1-5-4-8-6-3-7-2	1-3R-3-2R-2L-1R	1-5-3-6-2-4
Oil Pressure—Hot psi @ rpm	30-40	30-50	30-50	30-50	30-50	30-50	30-50	30-50	35-40	35-40		45-55

ENGINES (DIESEL) continued

	6-71NE-N55	6-71N-N60	6-71N-N65	8V-71NE-N55	8V-71N-N60	8V-71N-N65	V150D	V175D	V200D	V225D
Bore (inches)	4.250	4.250	4.250	4.250	4.250	4.250	4.500	4.500	4.500	4.500
Stroke (inches)	5.000	5.000	5.000	5.000	5.000	5.000	4.100	4.100	4.500	5.000
Brake Horsepower @ rpm	195 @ 1950	218 @ 2100	238 @ 2100	260 @ 1950	290 @ 2100	318 @ 2100	150 @ 3200	175 @ 3200	200 @ 3000	225 @ 2800
Max. Gross Torque lb.-ft. @ rpm	570 @ 1200	604 @ 1200	650 @ 1400	761 @ 1200	805 @ 1200	864 @ 1400	302 @ 1800	352 @ 1600	435 @ 1600	530 @ 1400
Compression Ratio	18.7:1	18.7:1	18.7:1	18.7:1	18.7:1	18.7:1	—	—	—	—
Displacement (cu. in.)	426	426	426	568	568	568	522	522	573	636

Specifications

F AND B 500 THRU 750, C AND W SERIES

FORD TRUCKS

ENGINE COOLING SYSTEM AND CRANKCASE REFILL CAPACITIES

(U.S. Measure)

GAS ENGINES

Engine	Truck Model	Cooling System	Crankcase
		Approx. Cap. (Qts.)	Approx. Cap. (Qts.)
240 Six	F-500, B-500	18	5 ^①
300 Six	F-500, B-500	18	5 ^①
300 HD Six	F-600, B-600	18	6 ^①
	C-550, C-600	22	
330 V-8	F-500, B-500, F-600, B-600, B-700	24 ^② 26 ^③	8 ^①
	C-550, C-600	28 ^② 29 ^③	
	F-600, B-600, F-700, B-700	24 ^② 26 ^③	
330 HD V-8	C-700, C-600	28 ^② 30 ^③	8 ^①
	F-600, B-600, F-700, B-700, F-750, B-750	24 ^② 26 ^③	
361 V-8	C-600, C-700, C-750, C-800, CT-800	28 ^② 30 ^③	8 ^①
	F-750, B-750	24 ^② 26 ^③	
391 V-8	C-750, C-800, CT-800	28 ^② 30 ^③	8 ^①

TRANSMISSION REFILL CAPACITIES

TRANSMISSION TYPE AND MAKE	FILLER LOCATION	DRAIN LOCATION	APPROX. CAPACITY (PINTS)
3-Speed Auxiliary (Spicer 5831)	Rt	L	4
3-Speed H.D. Auxiliary (Spicer 7231)	Rt	L	8
3-Speed H.D. Auxiliary (Spicer 8031)	Rt	L	12
3-Speed H.D. Auxiliary (Fuller 3K65)	Rt	B	13
4-Speed Auxiliary (Spicer 7041)	Rt	L	11
4-Speed Auxiliary (Spicer 8341)	Rt	L	12
4-Speed H.D. Auxiliary (Fuller 4E75)	Rt	B	12
4-Speed (New Process NP-435)	L	L	6½
4-Speed Warner T-19	Rt	Rt	6.4
5-Speed NPG542	Rt	Rear	9
5-Speed Heavy-Duty (Clark 280)	Rt	Center Rear	12
5-Speed (Spicer 8552A)	L	L	24
Spicer (F516)	L	L	28
Fuller RT0-913	L	B	27
5-Speed Extra Heavy Duty (Clark 380)	Rt	Center Rear	15
5-Speed Extra Heavy Duty (Spicer 5000)	Rt	L	13
5-Speed Extra Heavy Duty (Spicer 6000)	Rt	L	12
5-Speed (Fuller 5H74-A)	Rt	B	22
5-Speed (Fuller T-905-A & B)	L	B	22
10-Speed (Fuller RT & RTO-910)	L	B	26
10-Speed (Fuller RT-610)	L	B	12
12-Speed (Spicer 8312)	L	L	32
15-Speed (Fuller RT & RTO-915)	L	B	26
Transmatic Drive (MT-30, MT-40)	*Rt	L	38

*On a C-Series truck, the dipstick should be removed through the opening in the panel behind the seat back cushion with the cab in its normal position.

Rt—Right L—Left B—Bottom

DIESEL ENGINES

Engine	Truck Model	Cooling System	Crankcase
		Approx. Cap. (Qts.)	Approx. Cap. (Qts.)
C-160 CF-160 C-180	C-8000	34	4½
CAT. 1100 SERIES	F-6000, 7000 B-600, 6000, 7000	40 41	3
	C-6000, 7000, 8000	42	
	NH-230 NH-220, NHC-250	5	
8V-71N	W-1000-D, WT-1000-D	56	9½
NTC-335	W-1000-D, WT-1000-D	54	7½
6-71N	W-1000-D, WT-1000-D		

① Add 1 U.S. quart for trucks equipped with heater.

② Except with transmatic.

③ With transmatic

④ Add 1 quart extra when changing oil filter.

⑤ Add 2 quarts extra when changing oil filter.

⑥ Add 13 U.S. quarts or 11 Imperial quarts when equipped with optional by-pass filter.

REAR AXLE REFILL CAPACITIES

Tandem Axles		
Make and Model	Approximate Capacity (Pints) ①	
Eaton 30DSC 30DPC ②	Forward	30
	Rearward	27
Eaton 34DSC 34DPC 34DSE, 34DPE ③	Forward	29
	Rearward	32
Rockwell SLHD ④	Forward	32½
	Rearward	32
	Power Divider	2
Rockwell SHHD ⑤	Forward	22
	Rearward	21
	Power Divider	2
Single-Speed Axle		
Eaton 17121	29	
Eaton 18101, 18121	29	
Rockwell C-100 & D-100 ⑥	12½	
Rockwell F-106 ⑦	13	
Rockwell H-170 ⑧	18	
Rockwell R-171-B ⑨	43	
Rockwell Q-246A ⑩ ⑪	35	
Two-Speed Axle		
Eaton 15201 ⑫ ⑬	16½	
Eaton 16244 ⑭ ⑮	22½	
Eaton 17201, 17221 ⑯ ⑰	29	
Eaton 18201, 18221 ⑱ ⑲	29	
Rockwell Q-346 ⑳	23	

① Add two pints of lubricant to the inter-axle differential housing in addition to the specified amount when a new or reconditioned drive unit is installed.

② If hubs have been removed an additional ½ pint of axle lubricant must be added. Add lubricant through the axle vent.

③ If hubs have been removed an additional 1 pint of axle lubricant must be added. Add lubricant through the axle vent.

④ If hubs have been removed an additional 1½ pints of axle lubricant must be added. Add lubricant through the axle vent.

⑤ Quantities listed are approximate. Axle should be filled until lubricant is level with bottom of filler hole with vehicle in normal operating position.

⑥ Add one pint of lubricant to front filler in carrier assembly when new or reconditioned drive unit is installed. This quantity is included in the capacities shown.

⑦ Fill to bottom of filler hole.



AUTOLITE PART NUMBER

CYL.	ENG. CID	SPARK PLUG			IGNITION PARTS DIST.						PCV VALVE	ELECTRICAL TUNE-UP KIT
		STD.	RESISTOR	GAP	POINTS	COND.	CAP	ROTOR	COIL	TUNE-UP KIT		
FORD												
6 cyl. S/T 240		BF-42	BRF-42	.035"	DP-3 ¹	DC-13	DH-4	DR-87	DG-5	DK-16	EV-49	—
6 cyl. A/T 240		BF-42	BRF-42	.035"	DP-3 ¹	DC-13	DH-4	DR-87	DG-5	DK-16	EV-49	—
8 cyl. S/T 2 Bbl. Carb. 302		BF-42	BRF-42	.035"	DP-12 ²	DC-13	DH-6	DR-5	DG-5	DK-10	EV-50	TKF-1
8 cyl. A/T 2 Bbl. Carb. 302		BF-42	BRF-42	.035"	DP-12 ²	DC-13	DH-6	DR-5	DG-5	DK-10	EV-50	TKF-1
8 cyl. S/T 2 Bbl. Carb. 351 (w)		BF-42	BRF-42	.035"	DP-12 ²	DC-13	DH-6	DR-5	DG-5	DK-10	EV-50	TKF-1
8 cyl. A/T 2 Bbl. Carb. 351 (w)		BF-42	BRF-42	.035"	DP-12 ²	DC-13	DH-6	DR-5	DG-5	DK-10	EV-50	TKF-1
8 cyl. S/T 2 Bbl. Carb. 390		BF-42	BRF-42	.035"	DP-12 ²	DC-13	DH-6	DR-5	DG-5	DK-10	EV-50	TKF-1
8 cyl. A/T 2 Bbl. Carb. 390		BF-42	BRF-42	.035"	DP-12 ²	DC-13	DH-6	DR-5	DG-5	DK-10	EV-50	TKF-1
8 cyl. 4 Bbl. Carb. 428		BF-32	BRF-32	.035"	DP-12 ²	DC-13	DH-6	DR-5	DG-5	DK-10	EV-50	TKF-7
8 cyl. S/T 2 Bbl. Carb. 429		BF-42	BRF-42	.035"	DP-12 ²	DC-13	DH-6	DR-5	DG-5	DK-10	EV-50	TKF-1
8 cyl. A/T 2 Bbl. Carb. 429		BF-42	BRF-42	.035"	DP-12 ²	DC-13	DH-6	DR-5	DG-5	DK-10	EV-50	TKF-1
8 cyl. S/T 4 Bbl. Carb. 429		BF-42	BRF-42	.035"	DP-12 ²	DC-13	DH-6	DR-5	DG-5	DK-10	EV-50	TKF-1
8 cyl. A/T 4 Bbl. Carb. 429		BF-42	BRF-42	.035"	DP-12 ²	DC-13	DH-6	DR-5	DG-5	DK-10	EV-50	TKF-1
FAIRLANE												
6 cyl. A/T & S/T 250		BF-82	BRF-82	.035"	DP-3 ¹	DC-13	DH-4	DR-87	DG-5	DK-16	EV-49	TKF-6
8 cyl. S/T 2 Bbl. Carb. 302		BF-42	BRF-42	.035"	DP-12 ²	DC-13	DH-6	DR-5	DG-5	DK-10	EV-50	TKF-1
8 cyl. A/T 2 Bbl. Carb. 302		BF-42	BRF-42	.035"	DP-12 ²	DC-13	DH-6	DR-5	DG-5	DK-10	EV-50	TKF-1
8 cyl. S/T 2 Bbl. Carb. 351 (c)		AF-42	ARF-42	.035"	DP-12 ²	DC-13	DH-6	DR-5	DG-5	DK-10	EV-50	—
8 cyl. A/T 2 Bbl. Carb. 351 (c)		AF-42	ARF-42	.035"	DP-12 ²	DC-13	DH-6	DR-5	DG-5	DK-10	EV-50	—
8 cyl. S/T 4 Bbl. Carb. 351 (c)		AF-32	ARF-32	.035"	DP-12 ²	DC-13	DH-6	DR-5	DG-5	DK-10	EV-50	—
8 cyl. A/T 4 Bbl. Carb. 351 (c)		AF-32	ARF-32	.035"	DP-12 ²	DC-13	DH-6	DR-5	DG-5	DK-10	EV-50	—
8 cyl. S/T 4 Bbl. Carb. 429		BF-42	BRF-42	.035"	DP-12 ²	DC-13	DH-6	DR-5	DG-5	DK-10	EV-50	TKF-1
8 cyl. A/T 4 Bbl. Carb. 429		BF-42	BRF-42	.035"	DP-12 ²	DC-13	DH-6	DR-5	DG-5	DK-10	EV-50	TKF-1
8 cyl. S/T 429 CJ		AF-32	ARF-32	.035"	DP-114	DC-69	DH-6	DR-5	DG-5	—	EV-1	—
8 cyl. A/T 429 CJ		AF-32	ARF-32	.035"	DP-114	DC-69	DH-6	DR-5	DG-5	—	EV-1	—
FALCON												
6 cyl. S/T & A/T 200		BF-82	BRF-82	.035"	DP-3 ¹	DC-13	DH-4	DR-87	DG-5	DK-16	EV-49	TKF-6
8 cyl. S/T 302		BF-42	BRF-42	.035"	DP-12 ²	DC-13	DH-6	DR-5	DG-5	DK-10	EV-8	TKF-1
8 cyl. A/T 302		BF-42	BRF-42	.035"	DP-12 ²	DC-13	DH-6	DR-5	DG-5	DK-10	EV-8	TKF-1
MAVERICK												
6 cyl. S/T 170		BF-82	BRF-82	.035"	DP-3 ¹	DC-13	DH-4	DR-87	DG-5	DK-16	EV-49	TKF-6
6 cyl. A/T 170		BF-82	BRF-82	.035"	DP-3 ¹	DC-13	DH-4	DR-87	DG-5	DK-16	EV-49	TKF-6
6 cyl. S/T 200		BF-82	BRF-82	.035"	DP-3 ¹	DC-13	DH-4	DR-87	DG-5	DK-16	EV-49	TKF-6
6 cyl. A/T 200		BF-82	BRF-82	.035"	DP-3 ¹	DC-13	DH-4	DR-87	DG-5	DK-16	EV-49	TKF-6
MUSTANG												
6 cyl. S/T 200		BF-82	BRF-82	.035"	DP-3 ¹	DC-13	DH-4	DR-87	DG-5	DK-16	EV-49	TKF-6
6 cyl. A/T 200		BF-82	BRF-82	.035"	DP-3 ¹	DC-13	DH-4	DR-87	DG-5	DK-16	EV-49	TKF-6
6 cyl. S/T 250		BF-82	BRF-82	.035"	DP-3 ¹	DC-13	DH-4	DR-87	DG-5	DK-16	EV-49	TKF-6
6 cyl. A/T 250		BF-82	BRF-82	.035"	DP-3 ¹	DC-13	DH-4	DR-87	DG-5	DK-16	EV-49	TKF-6
8 cyl. S/T 2 Bbl. Carb. 302		BF-42	BRF-42	.035"	DP-12 ²	DC-13	DH-6	DR-5	DG-5	DK-10	EV-50	TKF-1
8 cyl. A/T 2 Bbl. Carb. 302		BF-42	BRF-42	.035"	DP-12 ²	DC-13	DH-6	DR-5	DG-5	DK-10	EV-50	TKF-1
8 cyl. 302 4 Bbl. Special		AF-32	ARF-32	.035"	DP-114	DC-69	DH-6	DR-5	DG-5	—	EV-42	—
8 cyl. S/T 2 Bbl. Carb. 351 (w)		BF-42	BRF-42	.035"	DP-12 ²	DC-13	DH-6	DR-5	DG-5	DK-10	EV-50	TKF-1
8 cyl. A/T 2 Bbl. Carb. 351 (w)		BF-42	BRF-42	.035"	DP-12 ²	DC-13	DH-6	DR-5	DG-5	DK-10	EV-50	TKF-1
8 cyl. S/T 4 Bbl. Carb. 351 (c)		AF-32	ARF-32	.035"	DP-12 ²	DC-13	DH-6	DR-5	DG-5	DK-10	EV-50	—
8 cyl. A/T 4 Bbl. Carb. 351 (c)		AF-32	ARF-32	.035"	DP-12 ²	DC-13	DH-6	DR-5	DG-5	DK-10	EV-50	—
8 cyl. 428 S/T (CJ)		BF-32	BRF-32	.035"	DP-114	DC-69	DH-6	DR-5	DG-5	—	EV-51	—
8 cyl. 428 A/T (CJ)		BF-32	BRF-32	.035"	DP-114	DC-69	DH-6	DR-5	DG-5	—	EV-51	—
THUNDERBIRD												
8 cyl. 429 C.I.D.		BF-42	BRF-42	.035"	DP-12 ²	DC-13	DH-6	DR-5	DG-5	DK-10	EV-50	TKF-1

¹ DP-70 Pivotless Point Set can be used.

² With Carter Carburetor.

³ DP-77 Pivotless Point Set can be used.

⁴ Universal Spark Plug Set 3162 can also be used.

⁵ Universal Spark Plug Set 3119 may also be used.

⁶ Universal Spark Plug Set.

APPLICATION CHART ...1970 VEHICLES

GEN./ALT.		STARTER		FILTERS			IGN. CABLE		BATTERY				
BRUSH SET	REGULATOR	BRUSH SET	SWITCH	OIL	AIR	GAS	SETS		STARTER CABLE	GROUND CABLE	STA-FUL	STD.	UNIFILL
							STATIC SHIELD	COPPER					
FORD													
GB-111	GR-341	SB-134	SW-3	FL-1	FA-52 ²	FG-14	3803 ⁵	2119	7106	7304	SV-22HF	—	—
GB-111	GR-341	SB-134	SW-3	FL-1	FA-52 ²	FG-14	3803 ⁵	2119	7106	7304	SV-22HF	—	—
GB-111	GR-341	SB-134	SW-3	FL-1	FA-50	FG-14	3162 ⁶	2162	7106	7304	SV-22HF	—	—
GB-111	GR-341	SB-134	SW-3	FL-1	FA-50	FG-14	3162 ⁶	2162	7106	7304	SV-22HF	—	—
GB-111	GR-341	SB-134	SW-3	FL-1	FA-50	FG-14	3162 ⁶	2162	7106	7304	SV-22HF	—	—
GB-111	GR-341	SB-134	SW-3	FL-1	FA-50	FG-14	3812 ⁴	2162	7106	7304	SV-24F	AL-24F	HVU-24F
GB-111	GR-341	SB-134	SW-3	FL-1	FA-50	FG-14	3812 ⁴	2162	7106	7304	SV-22HF	—	—
GB-111	GR-341	SB-134	SW-3	FL-1	FA-50	FG-14	3812 ⁴	2162	7106	7304	SV-24F	AL-24F	HVU-24F
GB-111	GR-341	SB-134	SW-3	FL-1	FA-41	FG-14	3812 ⁴	2162	7106	7304	—	—	HVU-27HF
GB-111	GR-341	SB-134	SW-3	FL-1	FA-50	FG-14	3162 ⁶	2162	7106	7304	—	—	HVU-27HF
GB-111	GR-341	SB-134	SW-3	FL-1	FA-50	FG-14	3162 ⁶	2162	7106	7304	—	—	HVU-27HF
GB-111	GR-341	SB-134	SW-3	FL-1	FA-50	FG-14	3162 ⁶	2162	7106	7304	—	—	HVU-27HF
GB-111	GR-341	SB-134	SW-3	FL-1	FA-50	FG-14	3162 ⁶	2162	7106	7304	—	—	HVU-27HF
GB-111	GR-341	SB-134	SW-3	FL-1	FA-50	FG-14	3162 ⁶	2162	7106	7304	—	—	HVU-27HF
FAIRLANE													
GB-111	GR-341	SB-134	SW-3	FL-1	FA-52	FG-14	3803 ⁵	2119	7106	7414	SV-22HF	—	—
GB-111	GR-341	SB-134	SW-3	FL-1	FA-50	FG-14	3162 ⁶	2162	7106	7414	SV-22HF	—	—
GB-111	GR-341	SB-134	SW-3	FL-1	FA-50	FG-14	3162 ⁶	2162	7106	7414	SV-22HF	—	—
GB-111	GR-341	SB-134	SW-3	FL-1	FA-50	FG-14	3162 ⁶	2162	7106	7414	SV-22HF	—	—
GB-111	GR-341	SB-134	SW-3	FL-1	FA-50	FG-14	3162 ⁶	2162	7106	7414	SV-24F	AL-24F	HVU-24F
GB-111	GR-341	SB-134	SW-3	FL-1	FA-50	FG-14	3162 ⁶	2162	7106	7414	SV-27F	—	—
GB-111	GR-341	SB-134	SW-3	FL-1	FA-50	FG-14	3162 ⁶	2162	7106	7414	SV-27F	—	—
GB-111	GR-341	SB-134	SW-3	FL-1	FA-50	FG-14	3162 ⁶	2162	7106	7414	—	—	HVU-27HF ⁹
GB-111	GR-341	SB-134	SW-3	FL-1	FA-50	FG-14	3162 ⁶	2162	7106	7414	—	—	HVU-27HF ⁹
GB-111	GR-341	SB-134	SW-3	FL-1	FA-50 ⁷	FG-39	3162 ⁶	2162	7106	7414	—	—	HVU-27HF ⁹
GB-111	GR-341	SB-134	SW-3	FL-1	FA-50 ⁷	FG-39	3162 ⁶	2162	7106	7414	—	—	HVU-27HF ⁹
MAVERICK													
GB-111	GR-341	SB-97	SW-3	FL-1	FA-52	FG-14	3803 ⁵	2119	7106	7414	SV-22HF	—	—
GB-111	GR-341	SB-97	SW-3	FL-1	FA-52	FG-14	3803 ⁵	2119	7106	7414	SV-22HF	—	—
GB-111	GR-341	SB-134	SW-3	FL-1	FA-52	FG-14	3803 ⁵	2119	7106	7414	SV-22HF	—	—
GB-111	GR-341	SB-134	SW-3	FL-1	FA-52	FG-14	3803 ⁵	2119	7106	7414	SV-22HF	—	—
MUSTANG													
GB-111	GR-341	SB-134	SW-3	FL-1	FA-52	FG-14	3803 ⁵	2119	7106	7414	SV-24F	AL-24F	HVU-24F
GB-111	GR-341	SB-134	SW-3	FL-1	FA-52	FG-14	3803 ⁵	2119	7106	7414	SV-24F	AL-24F	HVU-24F
GB-111	GR-341	SB-134	SW-3	FL-1	FA-52	FG-14	3803 ⁵	2119	7106	7414	SV-22HF	—	—
GB-111	GR-341	SB-134	SW-3	FL-1	FA-52	FG-14	3803 ⁵	2119	7106	7414	SV-22HF	—	—
GB-111	GR-341	SB-134	SW-3	FL-1	FA-50	FG-14	3162 ⁶	2162	7106	7414	SV-22HF	—	—
GB-111	GR-341	SB-134	SW-3	FL-1	FA-50	FG-14	3162 ⁶	2162	7106	7414	SV-22HF	—	—
GB-111	GR-341	SB-134	SW-3	FL-1	FA-41	FG-19	3162 ⁶	2162	7106	7414	SV-22HF	—	—
GB-111	GR-341	SB-134	SW-3	FL-1	FA-50 ⁸	FG-14	3162 ⁶	2162	7106	7414	SV-22HF	—	—
GB-111	GR-341	SB-134	SW-3	FL-1	FA-50 ⁸	FG-14	3162 ⁶	2162	7106	7414	SV-22HF	—	—
GB-111	GR-341	SB-134	SW-3	FL-1	FA-50 ⁷	FG-14	3162 ⁶	2162	7106	7414	SV-24F	AL-24F	HVU-24F
GB-111	GR-341	SB-134	SW-3	FL-1	FA-50 ⁷	FG-14	3162 ⁶	2162	7106	7414	SV-24F	AL-24F	HVU-24F
GB-111	GR-341	SB-134	SW-3	FL-1	FA-41	FG-19	3812 ⁴	2162	7106	7414	—	—	HVU-27HF ⁹
GB-111	GR-341	SB-134	SW-3	FL-1	FA-41	FG-19	3812 ⁴	2162	7106	7414	—	—	HVU-27HF ⁹
THUNDERBIRD													
GB-117	GR-383	SB-134	SW-3	FL-1	FA-50	FG-14	3162 ⁶	2162	7564	7234	—	—	HVU-27HF

² With Ram Air Use FA-74.

⁸ With Ram Air Use FA-41.

⁹ Trunk Mounted Battery Use SV-29HR.

(w) Windsor-built Engine.

(c) Cleveland-built Engine.

(CJ) Cobra Jet.



AUTOLITE PART NUMBER

CYL.	ENG. CID	SPARK PLUG			IGNITION PARTS DIST.						PCV VALVE	ELECTRICAL TUNE-UP KIT
		STD.	RESISTOR	GAP	POINTS	COND.	CAP	ROTOR	COIL	TUNE-UP KIT		
COUGAR												
8 cyl. 302 4 Bbl. Special		AF-32	ARF-32	.035"	DP-114	DC-69	DH-6	DR-5	DG-5	DK-10	EV-42	—
8 cyl. S/T 2 Bbl. Carb. 351 (w)		BF-42	BRF-42	.035"	DP-12 ^a	DC-13	DH-6	DR-5	DG-5	DK-10	EV-50	TKF-1
8 cyl. A/T 2 Bbl. Carb. 351 (w)		BF-42	BRF-42	.035"	DP-12 ^a	DC-13	DH-6	DR-5	DG-5	DK-10	EV-50	TKF-1
8 cyl. S/T 4 Bbl. Carb. 351 (c)		AF-32	ARF-32	.035"	DP-12 ^a	DC-13	DH-6	DR-5	DG-5	DK-10	EV-50	—
8 cyl. A/T 4 Bbl. Carb. 351 (c)		AF-32	ARF-32	.035"	DP-12 ^a	DC-13	DH-6	DR-5	DG-5	DK-10	EV-50	—
8 cyl. S/T 428 CJ		BF-32	BRF-32	.035"	DP-114	DC-69	DH-6	DR-5	DG-5	—	EV-51	—
8 cyl. A/T 428 CJ		BF-32	BRF-32	.035"	DP-114	DC-69	DH-6	DR-5	DG-5	—	EV-51	—
MONTEGO												
6 cyl. S/T 250		BF-82	BRF-82	.035"	DP-3 ¹	DC-13	DH-4	DR-87	DG-5	DK-16	EV-49	TKF-6
6 cyl. A/T 250		BF-82	BRF-82	.035"	DP-3 ¹	DC-13	DH-4	DR-87	DG-5	DK-16	EV-49	TKF-6
8 cyl. S/T 2 Bbl. Carb. 302		BF-42	BRF-42	.035"	DP-12 ^a	DC-13	DH-6	DR-5	DG-5	DK-10	EV-50	TKF-1
8 cyl. A/T 2 Bbl. Carb. 302		BF-42	BRF-42	.035"	DP-12 ^a	DC-13	DH-6	DR-5	DG-5	DK-10	EV-50	TKF-1
8 cyl. S/T 2 Bbl. Carb. 351 (c)		AF-42	ARF-42	.035"	DP-12 ^a	DC-13	DH-6	DR-5	DG-5	DK-10	EV-50	—
8 cyl. A/T 2 Bbl. Carb. 351 (c)		AF-42	ARF-42	.035"	DP-12 ^a	DC-13	DH-6	DR-5	DG-5	DK-10	EV-50	—
8 cyl. S/T 4 Bbl. Carb. 351 (c)		AF-32	ARF-32	.035"	DP-12 ^a	DC-13	DH-6	DR-5	DG-5	DK-10	EV-50	—
8 cyl. A/T 4 Bbl. Carb. 351 (c)		AF-32	ARF-32	.035"	DP-12 ^a	DC-13	DH-6	DR-5	DG-5	DK-10	EV-50	—
8 cyl. S/T 4 Bbl. Carb. 429		BF-42	BRF-42	.035"	DP-12 ^a	DC-13	DH-6	DR-5	DG-5	DK-10	EV-50	TKF-1
8 cyl. A/T 4 Bbl. Carb. 429		BF-42	BRF-42	.035"	DP-12 ^a	DC-13	DH-6	DR-5	DG-5	DK-10	EV-50	TKF-1
8 cyl. S/T 429 CJ		AF-32	ARF-32	.035"	DP-114	DC-69	DH-6	DR-5	DG-5	—	EV-1	—
8 cyl. A/T 429 CJ		AF-32	ARF-32	.035"	DP-114	DC-69	DH-6	DR-5	DG-5	—	EV-1	—
MERCURY												
8 cyl. S/T 2 Bbl. Carb. 390		BF-42	BRF-42	.035"	DP-12 ^a	DC-13	DH-6	DR-5	DG-5	DK-10	EV-50	TKF-1
8 cyl. A/T 2 Bbl. Carb. 390		BF-42	BRF-42	.035"	DP-12 ^a	DC-13	DH-6	DR-5	DG-5	DK-10	EV-50	TKF-1
8 cyl. 4 Bbl. Carb. 428		BF-32	BRF-32	.035"	DP-12 ^a	DC-13	DH-6	DR-5	DG-5	DK-10	EV-50	TKF-7
8 cyl. A/T 2 Bbl. Carb. 429		BF-42	BRF-42	.035"	DP-12 ^a	DC-13	DH-6	DR-5	DG-5	DK-10	EV-50	TKF-1
8 cyl. A/T 4 Bbl. Carb. 429		BF-42	BRF-42	.035"	DP-12 ^a	DC-13	DH-6	DR-5	DG-5	DK-10	EV-50	TKF-1
LINCOLN												
8 cyl. 4 Bbl. Carb. 460		BF-42	BRF-42	.035"	DP-12 ^a	DC-13	DH-6	DR-5	DG-5	DK-10	EV-8	TKF-1
MARK III												
8 cyl. 4 Bbl. Carb. 460		BF-42	BRF-42	.035"	DP-12 ^a	DC-13	DH-6	DR-5	DG-5	DK-10	EV-8	TKF-1

- (1) DP-70 Pivotless Point Set can be used.
- (2) With Carter Carburetor.
- (3) DP-77 Pivotless Point Set can be used.

- (4) Universal Spark Plug Set 3162 can also be used.
- (5) Universal Spark Plug Set 3119 may also be used.
- (6) Universal Spark Plug Set.

SHOCK ABSORBERS (Autolite Sales No.)

		Auto-Flex	Auto-Flex XD	Super-Flex
Ford	Front	AB-105	AX-110	—
	Rear	AB-104	AX-108	AA-134
Fairlane	Front	AB-16	AX-31	—
	Rear	AB-21 (Exc. S/W) AB-119 Sta. Wag.	AX-121 (Exc. S/W) AX-120 Sta. Wag.	AA-144 (Exc. S/W) AA-143 Sta. Wag.
Falcon	Front	AB-16	AX-31	—
	Rear	AB-21 (Exc. S/W) AB-119 Sta. Wag.	AX-121 (Exc. S/W) AX-120 Sta. Wag.	AA-144 (Exc. S/W) AA-143 Sta. Wag.
Mustang	Front	AB-123	AX-129	—
	Rear	AB-21	AX-76	AA-145
Thunderbird	Front	AB-105	AX-110	—
	Rear	AB-104	AX-108	AA-134
Maverick	Front	AB-154	—	—
	Rear	AB-155	—	—

APPLICATION CHART...1970 VEHICLES

GEN./ALT.		STARTER		FILTERS			IGN. CABLE		BATTERY				
BRUSH SET	REGULATOR	BRUSH SET	SWITCH	OIL	AIR	GAS	SETS		STARTER CABLE	GROUND CABLE	STA-FUL	STD.	UNIFILL
							STATIC SHIELD	COPPER					
COUGAR													
GB-111	GR-341	SB-134	SW-3	FL-1	FA-41	FG-19	3162*	2162	7106	7414	SV-22HF	—	—
GB-111	GR-341	SB-134	SW-3	FL-1	FA-50*	FG-14	3162*	2162	7106	7414	SV-22HF	—	—
GB-111	GR-341	SB-134	SW-3	FL-1	FA-50*	FG-14	3162*	2162	7106	7414	SV-24F	AL-24F	HVU-24F
GB-111	GR-341	SB-134	SW-3	FL-1	FA-50	FG-14	3162*	2162	7106	7414	SV-27F	—	—
GB-111	GR-341	SB-134	SW-3	FL-1	FA-50	FG-14	3162*	2162	7106	7414	SV-27F	—	—
GB-111	GR-341	SB-134	SW-3	FL-1	FA-41	FG-19	3812*	2162	7106	7414	—	—	HVU-27HF*
GB-111	GR-341	SB-134	SW-3	FL-1	FA-41	FG-19	3812*	2162	7106	7414	—	—	HVU-27HF*
MONTEGO													
GB-111	GR-341	SB-134	SW-3	FL-1	FA-52	FG-14	3803 ^s	2119	7106	7414	SV-22HF	—	—
GB-111	GR-341	SB-134	SW-3	FL-1	FA-52	FG-14	3803 ^s	2119	7106	7414	SV-22HF	—	—
GB-111	GR-341	SB-134	SW-3	FL-1	FA-50	FG-14	3162*	2162	7106	7414	SV-22HF	—	—
GB-111	GR-341	SB-134	SW-3	FL-1	FA-50	FG-14	3162*	2162	7106	7414	SV-22HF	—	—
GB-111	GR-341	SB-134	SW-3	FL-1	FA-50	FG-14	3162*	2162	7106	7414	SV-22HF	—	—
GB-111	GR-341	SB-134	SW-3	FL-1	FA-50	FG-14	3162*	2162	7106	7414	SV-24F	AL-24F	HVU-24F
GB-111	GR-341	SB-134	SW-3	FL-1	FA-50	FG-14	3162*	2162	7106	7414	SV-27F	—	—
GB-111	GR-341	SB-134	SW-3	FL-1	FA-50	FG-14	3162*	2162	7106	7414	SV-27F	—	—
GB-111	GR-341	SB-134	SW-3	FL-1	FA-50	FG-14	3162*	2162	7106	7414	—	—	HVU-27HF*
GB-111	GR-341	SB-134	SW-3	FL-1	FA-50	FG-14	3162*	2162	7106	7414	—	—	HVU-27HF*
GB-111	GR-341	SB-134	SW-3	FL-1	FA-50*	FG-14	3162*	2162	7106	7414	—	—	HVU-27HF*
GB-111	GR-341	SB-134	SW-3	FL-1	FA-50*	FG-14	3162*	2162	7106	7414	—	—	HVU-27HF*
MERCURY													
GB-111	GR-341	SB-134	SW-3	FL-1	FA-50	FG-14	3812*	2162	7106	7304	SV-22HF	—	—
GB-111	GR-341	SB-134	SW-3	FL-1	FA-50	FG-14	3812*	2162	7106	7304	SV-24F	AL-24F	HVU-24F
GB-111	GR-341	SB-134	SW-3	FL-1	FA-41	FG-14	3812*	2162	7106	7304	—	—	HVU-27HF
GB-111	GR-341	SB-134	SW-3	FL-1	FA-50	FG-14	3162*	2162	7106	7304	—	—	HVU-27HF
GB-111	GR-341	SB-134	SW-3	FL-1	FA-50	FG-14	3162*	2162	7106	7304	—	—	HVU-27HF
LINCOLN													
GB-117	GR-383	SB-134	SW-3	FL-1	FA-50	FG-14	3162*	2162	7564	7304	SV-29HR	—	HVU-29HR
MARK III													
GB-117	GR-383	SB-134	SW-3	FL-1	FA-50	FG-14	3162*	2162	7564	7304	SV-29HR	—	HVU-29HR

(7) With Ram Air Use FA-74.

(8) With Ram Air Use FA-41.

(9) Trunk Mounted Battery Use SV-29HR.

(w) Windsor-built Engine.

(c) Cleveland-built Engine.

(CJ) Cobra Jet.

SHOCK ABSORBERS (Autolite Sales No.)

		Auto-Flex	Auto-Flex XD	Super-Flex
Cougar	Front	AB-123	AX-129	—
	Rear	AB-21	AX-124	AA-145
Montego	Front	AB-16	AX-31	—
	Rear	AB-21 (Exc. S/W) AB-119 Sta. Wag.	AX-121 (Exc. S/W) AX-120 Sta. Wag.	AA-144 (Exc. S/W) AA-143 Sta. Wag.
Mercury	Front	AB-105	AX-110	—
	Rear	AB-104	AX-108	AA-134
Lincoln Continental	Front	AB-70	AX-58	—
	Rear	AB-90	AX-77	AA-132
Continental Mark III	Front	AB-105	AX-110	—
	Rear	AB-104	AX-108	AA-134

BULK RATE
 U. S. POSTAGE
PAID
 Permit No. 2744
 Detroit, Mich.

TORONTO AUTO PARTS 30280
 904 FRANKLIN AVE 067449
 TORONTO OH 43964

Autolite... the original equipment parts!

Here are some Autolite products "under the hood" of a typical 1970 Ford Motor Company car.

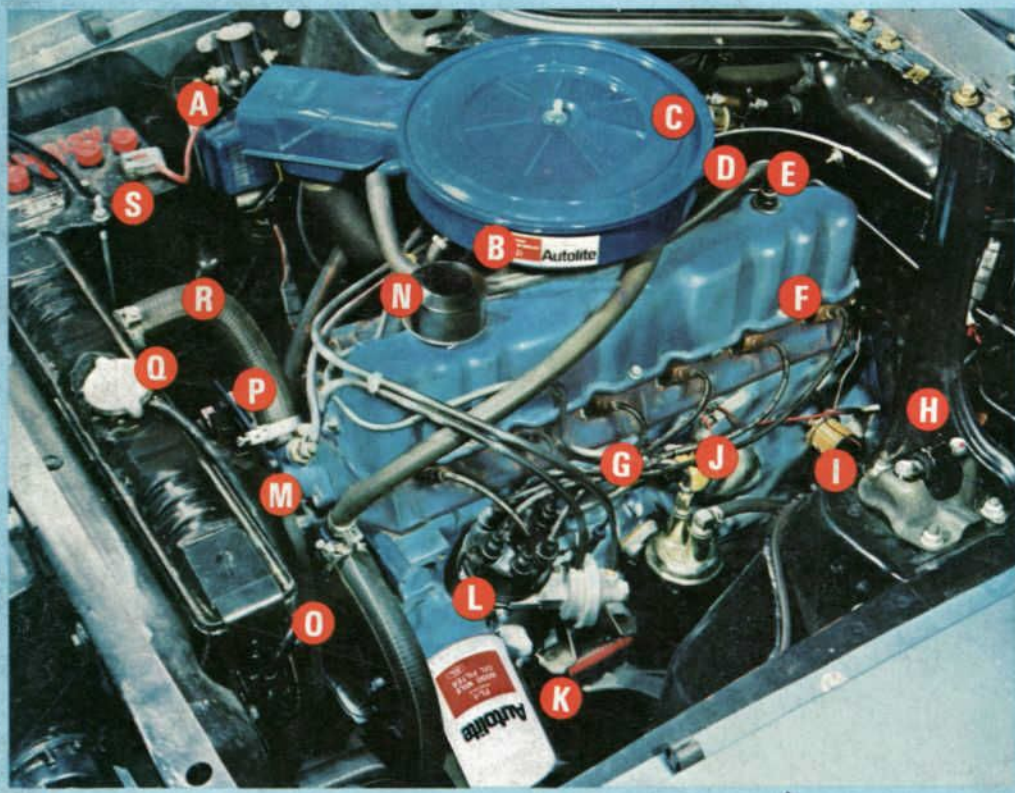

- | | |
|------------------------|---------------------|
| A—Regulator | J—Coil |
| B—Carburetor | K—Oil Filter |
| C—Air and Fuel Filters | L—Distributor |
| D—Starter | M—Thermostat |
| E—PCV Valve | N— Oil Breather Cap |
| F—Spark Plugs | O— Fan Belts |
| G—Wire and Cable | P— Alternator |
| H—Shock Absorbers | Q— Radiator Cap |
| I—Sending Units | R— Radiator Hoses |
| | S— Battery |

To keep that new car performance, always use Autolite Parts

