

- Exceptional Style
- Superb Riding Comfort
- Careful Engineering

File in Section C-6
Car Facts Organizer



THUNDERBIRD

A GREAT CAR FOR LIVING!

The 1974 Thunderbird is one of America's finest personal luxury automobiles with the style, comfort and ride that have become the hallmarks of the Thunderbird tradition.

The 1974 Thunderbird offers a host of standard luxury features that might cost extra in other cars in its class . . . features that provide the ultimate in luxury, comfort and convenience.



THUNDERBIRD sets the style!



Stylish touches like a classic hood ornament . . .



. . . plus a bold grille with attractive cross-hatch pattern continue the Thunderbird tradition of great style.

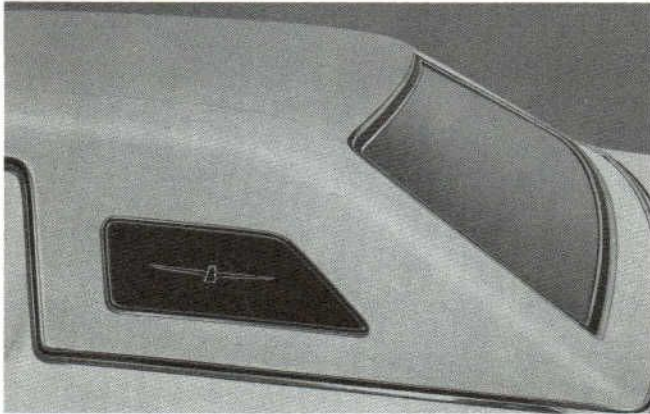

A deeply textured Odense grain vinyl roof and elegant opera windows establish Thunderbird's individuality.



INTERIOR LUXURY

And, inside, softly contoured, deep-cushioned split-bench seats with pull-down separate armrests offer the comfort and convenience of preferred individual seating.

Offered in addition to the standard cloth-and-vinyl trim, your customers may choose from *three* luxurious optional trims:

- Picardy velour
- Natural Grain Leather with vinyl trim
- All-vinyl

See your Car Facts Organizer for color availability.

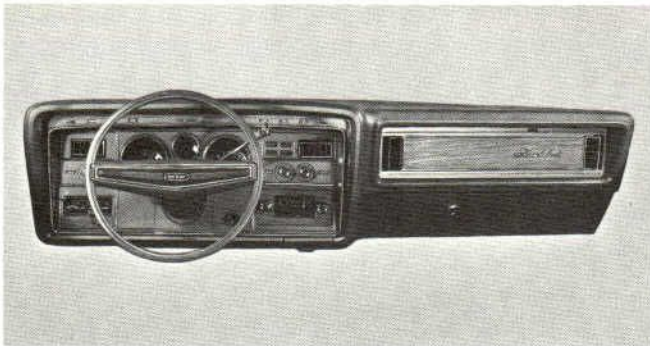

NEW COLOR-KEYED INSTRUMENT PANEL

And elegance has even been designed into the large easy-to-read instrument cluster, color-keyed to complement the interior.

THUNDERBIRD SAFETY FEATURES

- New 3-point seat belt restraint system
- Energy-absorbing steering column
- Energy-absorbing instrument panel
- Energy-absorbing torque box perimeter frame
- Energy-absorbing front and rear bumpers

THUNDERBIRD STANDARD EQUIPMENT

Thunderbird offers as standard, features including . . .

- SelectAire air conditioning with manual controls, four-speed blower and tinted glass
- Standard power side windows with convenient armrest controls . . . driver's controls canted and arranged in the same pattern as the windows
- Two-speed electric windshield wipers with dual-stream electric washers
- Standard automatic parking brake release
- Standard power disc front and power drum rear brakes
- Automatic seat back release
- AM Radio with dual front seat speakers
- WSW steel-belted radial ply tires
- Power steering

THUNDERBIRD group options



EXTERIOR DECOR GROUP

... features wide protective body-side moldings with padded inserts covered in rich Odense grain vinyl, color-keyed to the roof and front cornering lamps with side marker lights.



LIGHT GROUP

... features autolamp ON/OFF Delay System, front "lights-on" warning light and buzzer, low fuel and door ajar warning lights, dual overhead map lights, engine compartment light and lighted visor vanity mirror.



The new Autolamp automatically turns headlamps on at dark and off when daylight returns ... with a special sixty-second time-delay to allow you time to safely enter your home at night.

TURNPIKE CONVENIENCE GROUP ...

This option is ideal for buyers who frequently travel long distances. Included are Fingertip Speed Control, manual reclining passenger seat and trip odometer.

NEW FOR SEVENTY-FOUR

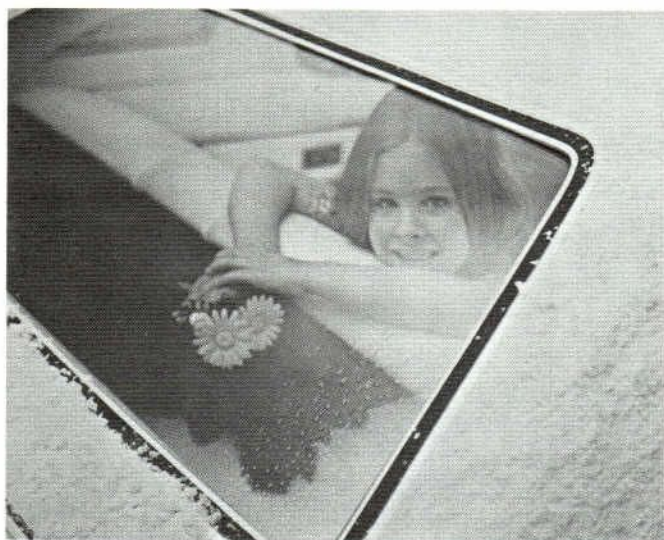

The new Quick Defrost Windshield/Rear Window similar to that used in jet aircraft, employs a conductive gold film laminated between the two layers of glass and when activated will completely clear the windshield and rear window faster than conventional hot air defrosters.



The new Thunderbird Moonroof is a power-operated sliding tinted glass panel that provides the open-air advantages of a convertible . . . the styling features of a hardtop . . . and the privacy of a luxury sedan.

**Some new options
to make Thunder-
bird even more
special . . .**

- Eight new Glamour Paints (Fire & Starfire finishes)
- Anti-Theft Alarm System
- Power Mini-Vent Windows
- Luggage Compartment Dress-up
- Body Stripe and Hood Paint Stripe
- Space-Saver Spare Tire

THUNDERBIRD body and chassis features

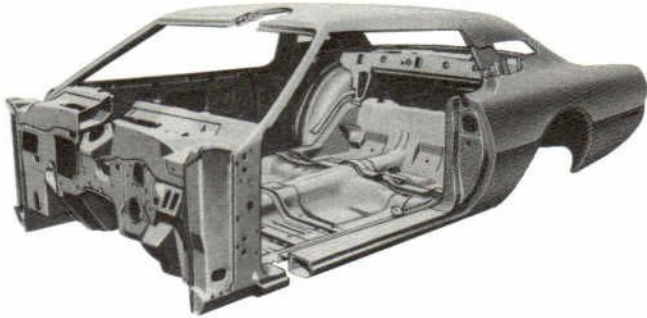

RIGID BODY CONSTRUCTION

Thunderbird's rigid body structure and torque box frame help reduce road shock, noise and vibration for a quiet, comfortable ride.

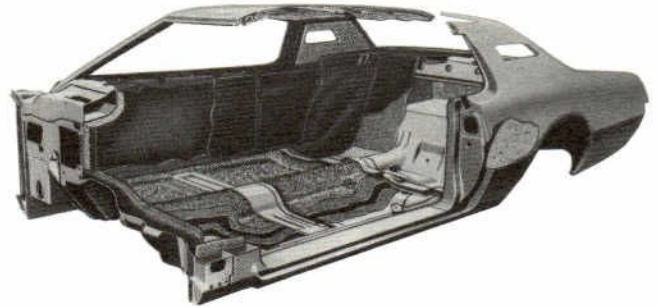

INSULATION AND SOUNDPROOFING

Nine-point insulation and soundproofing effectively reduce engine, transmission, power train and road noises.

THUNDERBIRD SUSPENSION FEATURES

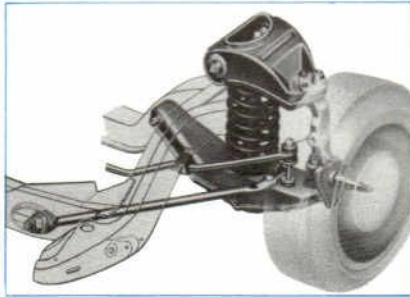

FRONT

Type Independent with Ball Joints and Drag Struts
 Springs Coil, Rubber-insulated
 Shock Absorbers Direct, Double-acting Hydraulic
 Stabilizer Bar Link-type, Rubber-bushed
 Wheel Bearings Taper Roller

REAR

Type Four Trailing Control Arms
 Springs Coil, Rubber-insulated
 Shock Absorbers Direct, Double-acting Hydraulic
 Stabilizer Bar Link-type

SUSPENSION SYSTEM

Thunderbird's "Posi-Ride" rear suspension features a four-link design which provides stability in all recommended conditions of loading. The front suspension features short and long ball-joint arms, plus springs and shock absorbers calibrated to match the weight/ride requirements.

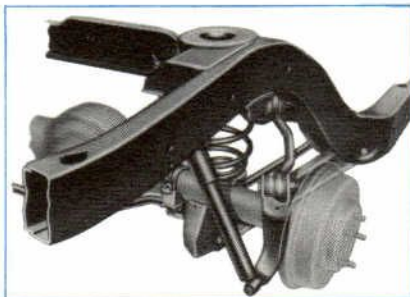

POWER TEAM SELECTIONS

Engine	Cruise-O-Matic Transmission	Rear Axle Ratios		
		Std.	Opt.*	Traction-Lok
460 CID 4V V-8	Standard	2.75 (a)	3.25	2.75 3.25*
460 CID (With Sure-Track)	Standard	2.75 (a)	3.25	2.75 3.25*

ALL RATIOS APPLICABLE TO AIR CONDITIONING

*Only available with trailer towing package (49 states only)
 (a) 3.00 standard California

This year's standard 460 4V V-8 engine features a new Solid-State electronic ignition for stronger spark.



At the time of release, specifications and prices contained herein are believed to be correct. Ford Division reserves the right to discontinue models at any time or change specifications, designs or prices without incurring obligation.

MORE THUNDERBIRD OPTIONS

- AM/FM Stereo Radio
- AM/FM Stereo Radio with Tape Player
- Sure-Track Brake Control System
- Tilt Steering Wheel
- Power Seats
- SelectAire Air Conditioner with Automatic Temperature Control
- Power-Operated Sunroof
- Dual Exhaust System
- Dual Bodyside and Hood Paint Stripes
- Color-keyed Wheel Covers*
- Simulated Wire Wheel Covers
- Deluxe Wheel Covers
- Luggage Compartment Trim

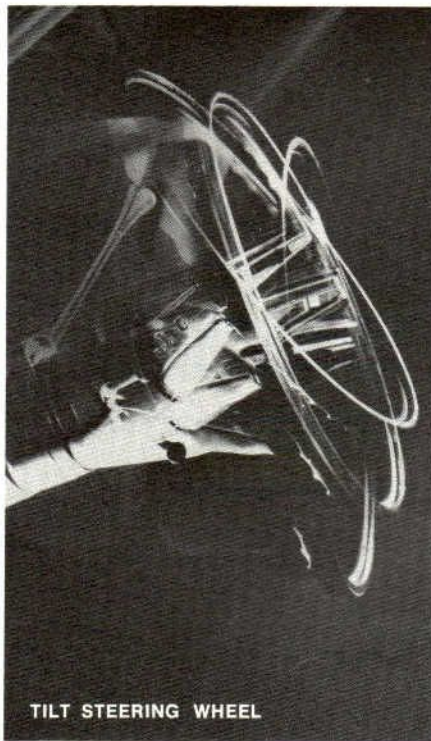
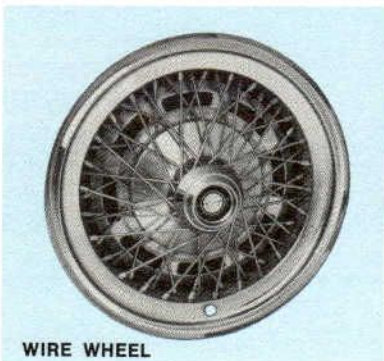

Just a few of the many additional options now available for Thunderbird buyers who want a little something extra.

*Available *only* with Glamour Paint Option



THUNDERBIRD

**Make a little Thunder
of your own.**

Thunderbird for '74. A motorcar of rare distinction with the enduring beauty of a classic from hood ornament to taillamps. Thunderbird . . . for those who want to put a little Thunder in their lives.



THUNDERBIRD INDEX

1974 THUNDERBIRD TWO-DOOR
 HARDTOP1, 3

BODY FEATURES

Body Construction.....6, 7
 Body Mounts.....7
 Body Sealing Material.....7
 Door Handles.....9
 Doors.....8
 Guard Rails, Steel.....See Section A, p. 6
 Headlights/Taillights.....9
 Hood.....8
 Instrument Panel.....9
 Insulation and Soundproofing.....7
 Luggage Compartment.....8
 Moisture Protection.....7
 Mirror, Left-Hand Remote-Control.....9
 Paint Process, Six-Step.....See Section A, p. 5
 Restraint System, 3-Point Occupant See Section A, p. 6
 Rust Prevention.....7
 Seat, Split Bench with Automatic Seat
 Back Release.....10
 SelectAire Air Conditioner.....9
 Starter Interlock & Warning
 Light Buzzer.....See Section A, p. 6
 Ventilation System, Power.....10
 Vinyl Roof & Opera Window.....9
 Windows, Power Side.....8
 Windows.....8
 Windshield Wipers, Concealed.....8

CHASSIS FEATURES

Brakes, Power Front Disc.....6
 Brake System.....See Section A, p. 2
 Bumper System,
 Energy Absorbing.....See Section A, p. 2, 3
 Frame.....5
 Parking Brake Release, Automatic.....6
 Shock Absorbers.....See Section A, p. 4
 Solid State Ignition.....See Section A, p. 5
 Steering Column,
 Energy Absorbing.....See Section A, p. 3
 Steering Column, Locking.....See Section A, p. 1
 Steering, Power.....5
 Steering Wheel.....5
 Suspension, Front.....5
 Suspension, Rear.....6

Suspension, Specifications.....6
 460 CID 4V Engine/Solid State Ignition.....6
 Tires.....See Section A, p. 4
 Wheels.....See Section A, p. 2

COLOR AND TRIM.....16

MARKET DATA.....2

OPTIONS

Complete Listing.....14
 Anti-Theft Alarm System.....11
 Bumper Group, Deluxe.....11
 Convenience Group.....12
 Decor Group, Exterior.....10
 Electric Rear Window Defroster.....12
 Light Group.....10, 11
 Moonroof, Power Operated, Glass.....13
 Paint Option, Glamour.....10
 Power Lock Group.....13
 Power Mini-Vent Windows.....13
 Appearance Protection Group.....11
 Quick Defrost Windshield/Rear Window.....12
 Seat, Manual Passenger Recliner.....13
 Seats, Power.....13
 SelectAire Conditioner with
 Automatic Temperature Control.....13
 Space Saver Spare Tire.....13
 Speed Control, Fingertip.....12, 13
 Steering Wheel, Tilt.....12
 Sunroof, Power Operated.....13
 Sure-Track Brake Control System.....12
 AM/FM Stereo Radio with Tape Player.....11
 AM/FM Stereo Search Radio.....11
 Traction-Lok Differential.....14
 Trailer Towing Package, Heavy-Duty.....14
 Turnpike Group.....11
 Wheel Covers, Color-Keyed.....14
 Wheel Covers, Deluxe.....14
 Wheel Covers, Wire.....14

SPECIFICATIONS

Body Dimensions.....15
 Brake Specifications.....15
 Power Team Selections.....15
 Steering Specifications.....15
 Wheel Specifications.....15

STANDARD EQUIPMENT.....4

THUNDERBIRD . . . ONE MODEL

HARDTOP

	Sales Code No.	Body Code No.
Two-Door	87	65K





THUNDERBIRD

Make a little Thunder of your own.

Thunderbird for '74. A motorcar of rare distinction with the enduring beauty of a classic from hood ornament to taillamps. Thunderbird . . . for those who want to put a little Thunder in their lives.



THUNDERBIRD HARDTOP



MODEL

2-Door Hardtop

Sales
Number
87



MAJOR STANDARD FEATURES

EXTERIOR

- Long 120.4" wheelbase, wide track . . . front 63" . . . rear 63.1" . . . with overall length 224.8"
- Energy-absorbing front and rear bumper systems . . . meet 1974 Federal Standards . . . 5 MPH front and rear impacts . . . 3 MPH corner impacts
- Odense grain vinyl roof available in Black, White, Blue, Green, Brown, Silver Blue, Gold, Tan and Copper
- Opera window in unique trapezoid design . . . Thunderbird emblem in glass . . . bright inside and outside molding
- Front bumper guards with vertical rubber inserts
- Concealed windshield wipers
- Distinctive grille features cross-hatch pattern, extruded aluminum construction and bright, die-cast peripheral molding
- Bright "Thunderbird" block letters over grille . . . bright oval hood ornament with "Thunderbird" emblem
- High-level front parking/turn signal lights on forward edge of front fenders
- Bright windshield and rear window moldings . . . bright drip, belt and rear hood edge molding
- Bodyside protection moldings with black vinyl insert and partial wheelip molding
- New 2-pod, segmented design taillight . . . 4 bulbs in each pod . . . 2 outboard bulbs on each side operate as turn signals . . . large backup light between taillights with die-cast "Thunderbird" emblem in center
- Bright, remote-control, left-hand outside mirror
- Full wheel covers
- Thicker, 3.9-mil, paint finish

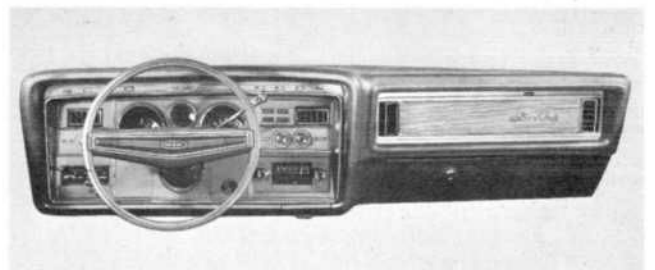

INTERIOR

- Individually adjustable split bench front seat with two fold-down center armrests and head restraints
- Aurora cloth seat trim with Corinthian vinyl facings
- Deep, cut-pile carpeting, front and rear . . . carpeting also included on lower portion of door trim panel
- Color-keyed vinyl-and-cloth door trim panel features a pull strap and courtesy light
- Deluxe color-keyed lap and shoulder belts . . . new 3-point restraint system
- Color-keyed instrument panel and cluster trim covers with thick-padded, energy-absorbing crash pads
- Color-keyed steering wheel and steering column
- Interior courtesy lights and luggage compartment light

FUNCTIONAL

- 460 CID 4V V-8 engine
- New Solid-State electronic ignition (See page G-6)
- SelectAire air conditioning with manual controls . . . 4-speed blower . . . integral heater . . . tinted glass—complete
- Power side windows
- Automatic seat-back release
- AM radio with dual front seat speakers
- SelectShift Cruise-O-Matic transmission
- Long-life, steel-belted radial ply WSW tires
- Two-speed electric windshield wipers with wiper-mounted, dual-stream, electric windshield washers
- Power ventilation system
- Automatic parking brake release
- Inside hood release
- Spare tire lock
- 77-ampere hour battery

See page G-4 for a complete list of standard equipment.

THUNDERBIRD STANDARD EQUIPMENT

The following features are standard on all 1974 Thunderbird models. In addition to the standard features listed, Thunderbird also includes as standard equipment the many Ford Lifeguard Design Safety Features listed on page i.

EXTERIOR

BODY AND FRAME CONSTRUCTION: Fully insulated, rust-resistant

BUMPERS, WRAPAROUND, ENERGY-ABSORBING: Meet 1974 Federal Standards . . . front bumper guards with rub strips

DOORS: Recessed door handles, ventless curved side glass

GALVANIZED ROCKER PANELS AND PRIMARY UNDERBODY COMPONENTS

GRILLE: Distinctive "cross-hatch" pattern and extruded aluminum construction . . . dual exposed headlamps with trim, bright peripheral molding

HOOD: Counterbalanced, front opening . . . inside hood release

KEYS: Reversible type, one-step keyless door locking system

LIGHTS: Backup lights
Integral, high-level park/turn signal lights . . . turn signals with lane-changing feature
Front and rear side marker lights
Hazard Flasher System
Headlamps, dual, horizontal with external adjustment feature
Taillamps, 2-pod design

MIRROR: Outside, left-hand, remote-control, inside rearview day/night, 12 inches long. Vanity mirror on right-hand sun visor

MOLDINGS: Bright drip and belt moldings
Bodyside protection molding with black vinyl insert
Partial wheelip moldings
Rear hood edge molding
Windshield reveal molding, bright finish
Rear window—bright molding all around

OPERA WINDOW: Unique trapezoid design . . . Thunderbird emblem in glass

ORNAMENTATION: Hood ornament with "Thunderbird" emblem . . . mounted with spring-loaded fold-back device
"Thunderbird" emblem in opera window glass
"Thunderbird" script on front quarter panels and rear deck lid
"Thunderbird" block letters over grille
"Thunderbird" ornament on backup light

PAINT: Acrylic enamel, reflow baking process . . . 3.9-mil thickness

TRUNK: Fully lined luggage compartment with light, lid counterbalanced . . . spare tire lock

VINYL ROOF: Odense grain . . . available in nine colors

WHEEL COVERS

INTERIOR

ACCELERATOR: Suspended type

ACCELERATOR AND BRAKE PEDAL PAD: Bright appliqué (brake pad has disc brake identification)

ARMRESTS: Front and rear, integral with door and quarter trim panels
Two front-center, pull-down type armrests integral with split bench seat

ASH TRAYS: Front, in instrument panel (lighted)
Rear, at rear of front-door armrests, includes cigar lighter and light
Front-seat passenger ash tray

BRAKE: Bright pedal trim

CARPETING: Cut-pile . . . front, rear and on lower door panel

CIGARETTE LIGHTER: In instrument panel (lighted) . . . in front-seat passenger and rear-seat ash trays

CLOCK, ELECTRIC: Self-regulating

COAT HOOKS: Two, pliable plastic, safety-type

COURTESY LIGHTS: Under instrument panel light

Ash tray lights
Door courtesy light
Dome light
Glove compartment light
Luggage compartment light
Illuminated air conditioning/heater controls

DOORS: Door checks, 2-stage (2-position checks)
Door handles, inside: Safety-designed, "paddle"-type
Door latches: Safety-yoke type
Door lock push-button: Chrome

GLOVE BOX: Lighted, twist-type knob

HEADLINING: All-vinyl, color-keyed

HEAD RESTRAINTS: For driver and front outboard passenger

IGNITION LIGHT

INSTRUMENT PANEL, COLOR-KEYED: Cluster trim covers, thick color-keyed crash pads

INTERIOR DOOR LOCK: Bright buttons

MIRROR: Inside rearview (day/night) attached to windshield, vinyl backed and framed, arms and bracket are chrome-plated, double-ball swivel, 12-inch length

RESTRAINT SYSTEM: 3-Point, deluxe color-keyed lap and shoulder belts front outboard occupants (single-tongue attachment with retractors)

LAP BELTS: Deluxe color-keyed front center occupant and all rear-seat occupants

SEATS: Individually adjustable split bench front seats . . . 3-passenger with center armrests up, safety-padded, self-locking backs with energy-absorbing structure and 2 center fold-down armrests, cloth with vinyl facings

Rear, bench-type, 3-passenger
Side shields, front with bright moldings

STEERING WHEEL: Color-keyed

WARNING LIGHTS: Brake warning light, "Fasten Belts," oil, alternator, temperature lights

FUNCTIONAL

AIR CONDITIONER: SelectAire manual controls, 4-speed blower with integral heater system

ALTERNATOR: 61-ampere

BATTERY: 77-ampere-hour

BRAKES: Parking brake, foot-applied, automatic vacuum release service brakes
Power disc front/power drum rear
Self-adjusting

ENGINE: 460 CID 4V V-8 with exhaust emission control system, positive crankcase ventilation system (See Power Teams section for details.)

TINTED GLASS: Complete

HOOD RELEASE: Inside

SOLID STATE IGNITION: (See page A-5 for details)

POWER SIDE WINDOWS

RADIO: AM with dual front-seat speakers

AUTOMATIC SEAT-BACK RELEASE

SIDE IMPACT PROTECTION: Steel guard rails in doors

SPARE TIRE LOCK

STEERING: Power

SUSPENSION: Front—coil springs between frame and lower arms, rubber-bushed stabilizer bar and struts
Rear—"Posi-Ride" 4-link coil with stabilizer bar (See pages G-5 and 6 for details)

TIRES: Long-life, steel-belted radial ply WSW

TRANSMISSION: SelectShift Cruise-O-Matic (3-speed automatic)

VENTILATION: Power with one-way valve air outlet

WINDSHIELD WASHERS: Electric pump actuated, dual-stream nozzles

WINDSHIELD WIPERS: Electric 2-speed concealed, articulated driver's side wiper arm

THUNDERBIRD FEATURES

CHASSIS FEATURES

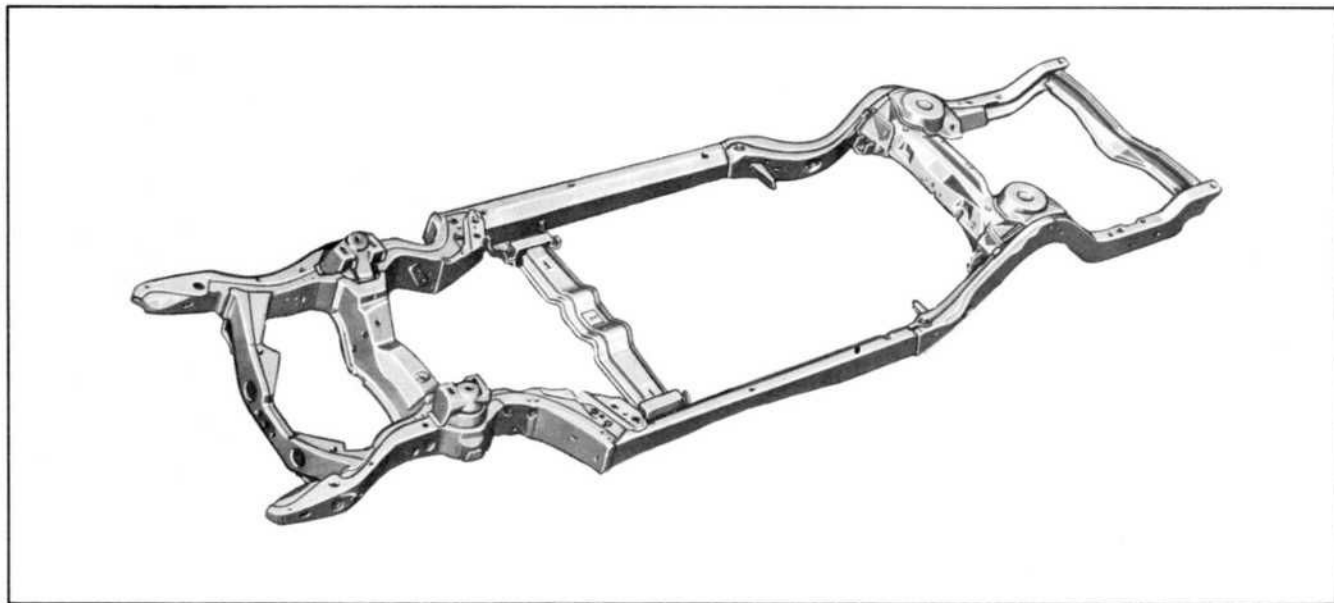

FRAME

Thunderbird for 1974 features a frame incorporating Ford's famous torque box design, which substantially reduces road shock to passengers, providing a smooth, comfortable ride.

The torque box perimeter frame also features an energy-absorbing front and rear section. Features of this design are:

A front frame crossmember composed of two heavy-gauge stampings fused into a solid box structure by an electron beam welding process.

Integral front torque boxes help reduce steering column rearward displacement on impact and help isolate road harshness.

The number three crossmember, which serves as the engine and transmission rear support, is a full-width steel stamping with its ends cushioned in rubber isolators to help reduce transmission of engine vibrations into the passenger compartment.

The number four crossmember is a massive formed steel plate, designed for maximum strength in minimum space. Upper seats for the rear coil springs and mountings for the rear shock absorbers are welded to this crossmember and the side rails. Upper links of the rear suspension attach to this crossmember.

Body mounts positioned by Ford's "bridging" principle—ahead of and behind the passengers—to isolate the body from the frame and minimize noise and vibrations.

STEERING WHEEL

For 1974, Thunderbird features a color-keyed steering wheel. The semi-oval rim design eases entrance and exit.

POWER STEERING

Thunderbird's steering system is a parallelogram linkage-type. Features of the system include:

A belt-driven hydraulic pump supplies the power for the control unit.

An integral control valve and steering gear design provide instant response to wheel movement.

A built-in low restriction feature of the control valve allows

the wheels to quickly return to center position after making a turn.

The torsion bar element of the steering shaft provides the driver with "feel" of road.

21.76 to 1 overall steering ratio provides fast, responsive steering.

See page G-15 for power steering specifications.

FRONT SUSPENSION

Thunderbird uses a short and long arm ball-joint front suspension. Springs and shock absorbers are calibrated to match the weight/ride requirements. Front suspension features include:

Single lower axial strut stabilizer arms, mounted to the frame through rubber bushings, which eliminate metal-to-metal contact and reduce the amount of vibration and noise transmitted to the passenger area.

The axial struts are anchored to the frame in large rubber bushings, allowing the wheels to move slightly longitudinally when hitting a bump. This controlled movement helps reduce the initial road shock before it reaches the passenger area.

A link-type, rubber-bushed stabilizer bar connects the right- and left-hand lower suspension arms to help control body roll when cornering. The front suspension provides a significant contribution to ride that customers associate with Thunderbird.

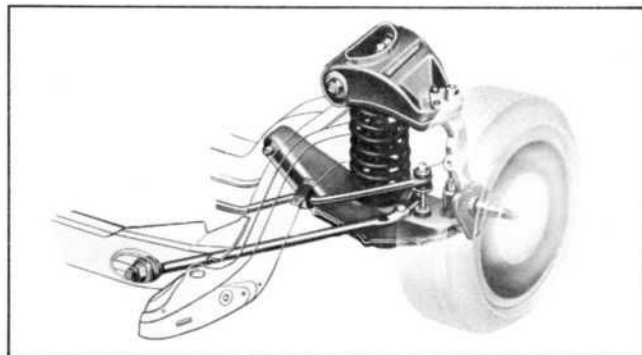

THUNDERBIRD FEATURES

Chassis Features (Cont'd)

REAR SUSPENSION

For 1974, Thunderbird continues to feature a "Posi-Ride" rear suspension system. The design features a four-link system which provides stability to the car in all recommended conditions of loading. The coil springs, as in the front suspension, are computer selected to help provide the exceptionally smooth ride. Features of the system include:

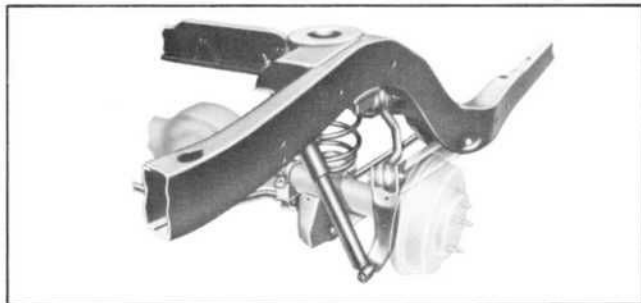

Four diagonally splayed arms control the position of the rear axle assembly and absorb braking and accelerating forces.

The lateral location of the axle is maintained due to the interaction of the arms. The lower arms are splayed inward from their attachment at the frame, and the shorter upper arms are splayed outward from their attachment at the frame. This arrangement gives the car directional stability and roll control.

Coil springs are seated on the axle and in deep rubber-insulated caps in the frame.

The arrangement of the control arms helps stabilize the vehicle in roll; however, additional stability is assured by a link-mounted rear stabilizer bar.

Shock absorbers are mounted at a 50° angle to help provide a smooth, flat ride with good lateral damping. Shock absorbers also feature a freon-filled bag in each fluid reservoir, designed to prevent foaming under high velocity shock absorber motions and to improve shock absorber damping

ability under these conditions. Double-acting compression control valves are used to provide a "boulevard" ride and also to cushion the shock of harsh impacts.

THUNDERBIRD SUSPENSION SPECIFICATIONS

FRONT

Type.....	Independent with Ball Joints and Drag Struts
Springs.....	Coil, Rubber-Insulated
Shock Absorbers.....	Direct, Double-Acting Hydraulic
Stabilizer Bar.....	Link-Type, Rubber-Bushed
Wheel Bearings.....	Taper Roller

REAR

Type.....	Four Trailing Control Arms
Springs.....	Coil, Rubber-Insulated
Shock Absorbers.....	Direct, Double-Acting Hydraulic
Stabilizer Bar.....	Link-Type

POWER BRAKES

All 1974 Thunderbirds have dual-hydraulic power brakes with front discs and rear drum brakes as standard equipment. Ford-developed brakes are designed to provide long lining life, easy servicing and excellent fade resistance. (See Section A, page 2 for additional details.)

AUTOMATIC PARKING BRAKE RELEASE

To avoid inadvertently driving with the parking brake fully or partially on, the 1974 Thunderbird incorporates, as standard equipment, an automatic release for the brakes. When the transmission is shifted out of Park or Neutral with the engine running, a vacuum piston within the parking brake system is actuated to disengage the parking brake.

460 CID 4V ENGINE WITH SOLID-STATE ELECTRONIC IGNITION

All 1974 Thunderbirds have the powerful 460 4V engine as standard equipment. (See Power Teams Section for additional details.) The 460 will feature Ford's new Solid-State electronic ignition that provides stronger spark for better starting and reduced hydrocarbon emissions. (See Section A, page 5 for details.)

BODY FEATURES

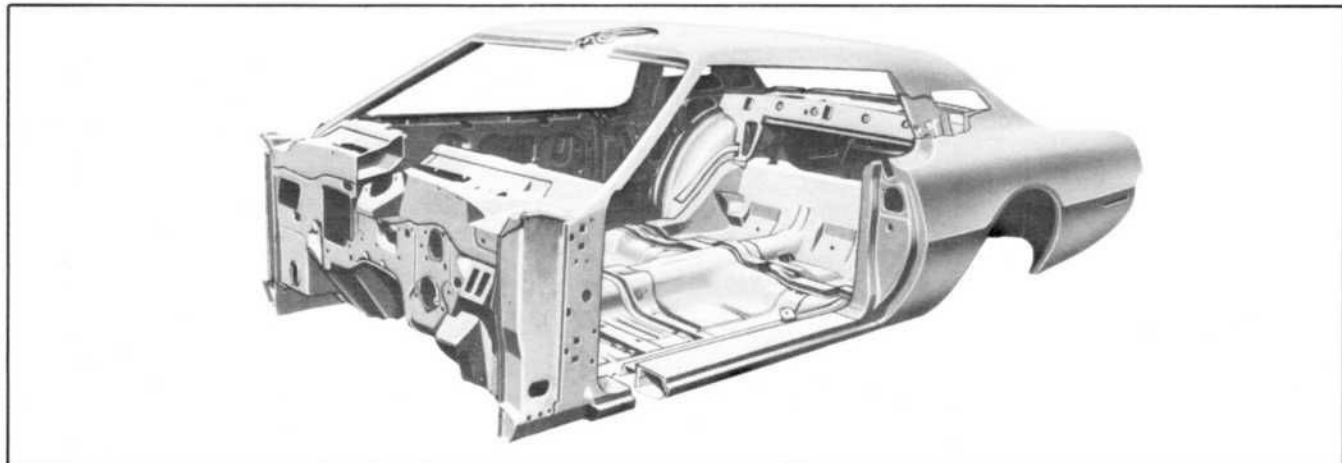

BODY CONSTRUCTION

Thunderbird's rigid body structure and the unique torque box frame work together to reduce road shock, noise and

vibration and reduce the amount being transmitted to the passenger compartment. Features that help make Thunderbird strong and quiet are:

THUNDERBIRD FEATURES

Body Features (Cont'd)

Rigid body construction, coupled with the use of computer-located body mounts in mounting the body to the torque box frame, results, in substantial insulation of the passengers from noise, vibration and harshness.

Heavy sheet metal crossmembers are used in front seat and rear seat areas. Stamped-in stiffeners add strength to the floor panel.

Reinforced double-panel construction of the rocker panels is further strengthened by a U-channel section which acts as a secondary bridge support to the body. Center and corner pillars are a box section constructed of heavy-gauge sheet metal.

The roof construction features rigid box section rails at the front, side and rear window headers with reinforcement bows under the roof panel. The Thunderbird roof meets or exceeds the Federal requirements for roll-over tests.

See page A-6 for details.

MOISTURE PROTECTION

Thunderbird's body design incorporates drain gutters to direct moisture away from where it is harmful. The body structure contains several applications of this design feature, one being the luggage compartment opening drain trough, which forms the perimeter of the trunk opening. The trough size is extra-large to provide greater water run-off and help prevent moisture from entering the trunk.

Less noticeable is a trough beneath each back window which extends out over the wheelhouse to drain any leakage from the backlite seal away from the luggage compartment. Another trough is formed into the rear floor components to drain any unforeseen leakage from taillamp openings away from the luggage area.

All structural joints are also "shingled" in the most effective direction of overlap with relation to the expected direction of water flow.

BODY MOUNTS

Fourteen special rubber body mounts are "computer-tuned" to specific mounting locations to help isolate the passenger compartment from the frame. The tapered design of the mounts helps reduce road vibrations and provide a quiet ride.

RUST PREVENTION

To protect the bodies of all Thunderbird models against corrosion, galvanized steel is used in key body areas and a zinc-rich primer is also sprayed on critical body areas. Features of this anti-corrosion protection include:

The use of one-piece, molded-plastic, front fender aprons over the wheels to help eliminate apron corrosion.

Use of concentrated zinc-rich primer.

Galvanized steel is used for the rocker panel and side sills.

Use of weld studs and adhesive eliminates drilled holes in body panels.

One-way drain valves used as sealing devices to provide adequate drainage and prevent dust and dirt from entering between the body paneling.

In addition, the Thunderbird body is subjected to a thorough sheet metal cleansing and paint preparation process. The process includes cleansing of the sheet metal by a hot alkali solution, a complete spraying with zinc phosphate, and washing with chromic and phosphoric acid. This cleansing process contributes materially to the remarkable finish on the car.

Selected areas of the underbody are also given heavy coats of high-quality undercoating to complete the protection treatment.

BODY SEALING MATERIAL

The following joint sealers and special anti-squeak and sealing devices are used in the Thunderbird to help assure a comfortable, quiet ride:

Plastic sealing material applied to exposed spot-welded body panel seams and joints.

Vinyl-plastic seals on the drip rails and rear deck trough.

Windshields and backlites sealed with butyl tape.

Special pads, grommets, seals and plug buttons guard against water, dust and drafts.

Heat-curing sealer applied to all other panel seams and joints.

Large diameter, tubular weatherstripping provides tight seals around all doors.

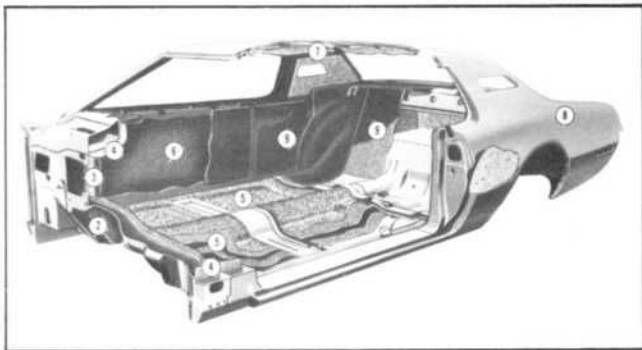

INSULATION AND SOUNDPROOFING

Thunderbird's insulation and soundproofing effectively reduce engine, transmission, power train and road noises . . . and also provide increased protection against heat and cold.

- (1) The hood has mastic adhesive spotted between the inner and outer panels, and glass fiber pads are cemented to the underside of the hood to absorb and deaden engine noises.
- (2) Selected portions of the underbody are sprayed with sound-deadener coating.
- (3) Molded textile-fiber insulator pads with plastisol coating on the rear side are used on the dash-panel inner surface.
- (4) One-half-inch fiberglass pads are cemented to the cowl sides, and the underside of the cowl top panel is covered with a heavy fiber pad, serving as both a heat insulator and sound-deadener.
- (5) The front floor pan and tunnel sides are covered with a new semi-septum type material, consisting of crepe kraft-coated heavy mastic combined with one-quarter-inch fiber batting. In addition, the entire tunnel top is covered with fiberglass and aluminum foil pads. The rear passenger floor area, floor side risers and floor rear risers are covered with a layer of crepe kraft-coated heavy mastic. Both the front and rear floor carpeting is padded with a thick jute pad.
- (6) Spray-on sound-deadener coating is applied to the inner surfaces of the door and quarter panels and an Amberlite deadener pad is placed between the trim panel and the water shield.
- (7) Sound-deadener felt strips are placed between the roof crossmembers and the underside of the roof panel. One-half-inch thick, high-density fiber pads cover the roof sections between the crossmembers, and thick glass fiber covers the inside of the roof rear pillars.
- (8) The deck lid has inner and outer panel construction, with mastic adhesive spotted between the panels. The luggage compartment floor is covered with a felt mat. Side panels are lined with heavy fiber panels.
- (9) The rear wheelhousings and seat-back strainer are covered with a 3/8" fiber pad with polyethylene film. Quarter inner panels are covered with 3/8" fiber pad.

THUNDERBIRD FEATURES

Body Features (Cont'd)



HOOD

A hood ornament is standard on the Thunderbird for '74. The oval ornament features a "Thunderbird" emblem and is spring-mounted to fold back upon impact.

The hood features double-panel construction with the inner panel formed into channel-type reinforcing sections. The inner and outer panels are welded at the outer edges of both panels, and the reinforcing channels are bonded to the outer panels with a special heat-cured adhesive. The power-dome section of the hood forms a deep channel from front to rear that gives added strength and rigidity.

Fiberglass padding bonded to the underside of the hood panel reduces engine noise. A full-width cowl seal and adjustable, molded rubber pads at the fender line help seal and align the hood with the fender line. Counterbalancing coil springs and double-link hinges provide for easy raising and lowering of the hood. An inside hood release, conveniently located under the instrument panel to the left of the steering column, provides increased protection against theft.

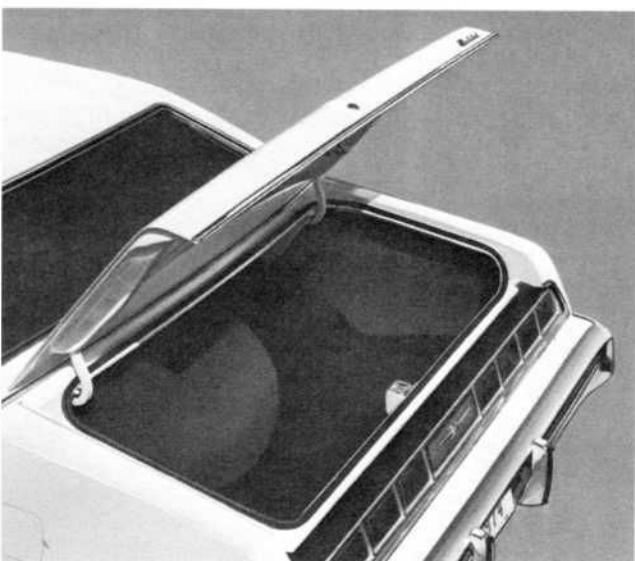

LUGGAGE COMPARTMENT

The 1974 Thunderbird offers 13.4 cubic feet of usable luggage compartment capacity. The entire luggage compartment area is lined with a mat to help prevent scuffing of cargo.

The spare tire is mounted on a raised area over the rear axle,

providing a large unobstructed area for stowage. A spare tire lock is included.

Built-in torsion bars assist in raising the deck lid and holding it open. Compression-type, neoprene rubber weatherstripping provides a seal against dirt and moisture.

A new luggage compartment trim option (shown) with 10½-oz. carpeting is available as an option.

CONCEALED WINDSHIELD WIPERS

Windshield wipers on the Thunderbird are recessed below the line of sight on the cowl. Windshield glass extends downward into the hidden wiper slot so that wiper blades are never required to rest off the glass.

WINDOWS

Thunderbird's tinted side and backlite windows are high-strength impact-resistant, heat-tempered glass. The windshield is constructed of two sheets of glass which are sandwiched to a 30-mil thick plastic sheet and heat-laminated together. This type of windshield construction provides exceptional strength and pliability, which enables the windshield to take "more stretch and impact" without injury-producing penetration.

The ventless, front side-windows complement Thunderbird's clean styling lines. A side-glass regulator bracket features bolts that pass through holes near the bottom of the glass to mechanically retain the side glass.



POWER SIDE WINDOWS

All 1974 Thunderbirds feature power side windows as standard equipment. The power window controls are conveniently located in the "control console" on the driver's door armrest to let the driver adjust all windows as desired. A master over-riding lock feature can be used to lock out operation of individual passenger controls which are located on the passenger door armrest and rear quarter trim panels. A new mini-vent window is available as an option, see page G-13 for additional details.

DOORS

The Thunderbird doors are formed into a warp-free, sturdy box unit through the use of double-panel, welded construction. Bronze-bushed hinges provide long wear and easy opening and closing. All doors incorporate check straps to hold the doors in the full open position. The check straps also provide an intermediate door check position to aid entry and exit when parked in close quarters. Compression-type weather

THUNDERBIRD FEATURES

Body Features (Cont'd)

sealing provides a tight seal and low resistance to door closing. Strong bear-hug door latches are enclosed in the door sheet metal. The latches provide secure closing, easy opening, rattle-resistance and help protect against accidental opening on impact. Steel Guard Rails are also featured. See Section A, page 6 for details.

DOOR HANDLES

Thunderbird's exterior handles are pull-out type, recessed in the door. They are encased in a bright metal frame.

Keyless one-step locking is also featured. The doors may be locked from the outside by simply depressing the inside door lock control knob, and then closing the door. With the incorporation of the outside recessed door handles, the need to depress an exterior push-button for locking is no longer required.

The inside door handle is recessed in the side of the full-length armrest. The handle is paddle-shaped and actuates the door latch when pulled with the fingertips. The handle overrides the locking mechanism, eliminating the need to raise the door lock button from its locked position.

A convenient pull strap is mounted in the center of the door above the armrest for pulling the door closed from the extended position.

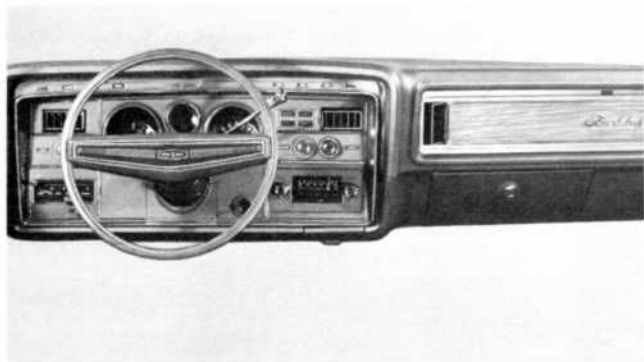

INSTRUMENT PANEL

Thunderbird's instrument panel is a color-keyed steel/plastic design. The upper portion of the panel features padding over sheet metal, while the lower portion is molded plastic with a textured leather-like surface. The color-keyed instrument cluster and controls are enclosed in a large hooded rectangle directly in front of the driver. The clock, fuel gauge and speedometer/odometer are located in the center of the cluster. To the left are air register, light switch, or optional auto lamp and air conditioning/heater, controls.

In the right portion of the cluster are an air register, windshield wiper/washer controls, cigarette lighter, radio and a lighted pull-out ash tray. A narrow strip above the cluster contains the turn signal, brake light, high-beam light, seat belt reminder, engine temperature, alternator and oil lights. The inside hood release is located under the instrument panel, left of the steering column, and the optional remote-control, right-hand mirror control is to the right of the steering column on the lower portion of the instrument panel.

The passenger side of the panel is highlighted by a simulated woodgrain rectangular appliqué and includes two air registers. The glove box door has a twist-type lockable knob to facilitate opening.

HEADLIGHTS/TAILLIGHTS

The 1974 Thunderbird has exposed, dual headlights. Provision for external headlamp adjustment permits precise headlamp alignment in minutes, without removing the headlight trim rings.

The new taillights feature two pods in place of the full-width design used in 1973. Each pod has four bulbs, with the two outboard bulbs, on each side, serving as stop lights and turn signals. A new large backup light, with two bulbs, is positioned between the two taillights.

LEFT-HAND REMOTE-CONTROL MIRROR

A bright, left-hand, remote-control mirror is standard. The mirror control is on the driver's armrest control panel for easy, quick adjustment.

SELECTAIRE AIR CONDITIONER

All 1974 Thunderbirds feature a heater/air conditioning system as standard equipment. This system features a fast initial cool-down rate and utilizes a suction throttling valve to regulate the evaporator temperature. A magnetic clutch constantly drives the compressor, instead of cycling it to regulate the cooling. As a result, the evaporator is always cold, permitting uniform temperatures out of registers and faster response to temperature control changes. All air passes through the evaporator, providing maximum dehumidification. The system features a four-speed blower, air conditioning position, heat and vent positions, and defrost and intermediate defrost/heat positions. A Hi/Lo position directs air through both the instrument panel vents and floor vents.

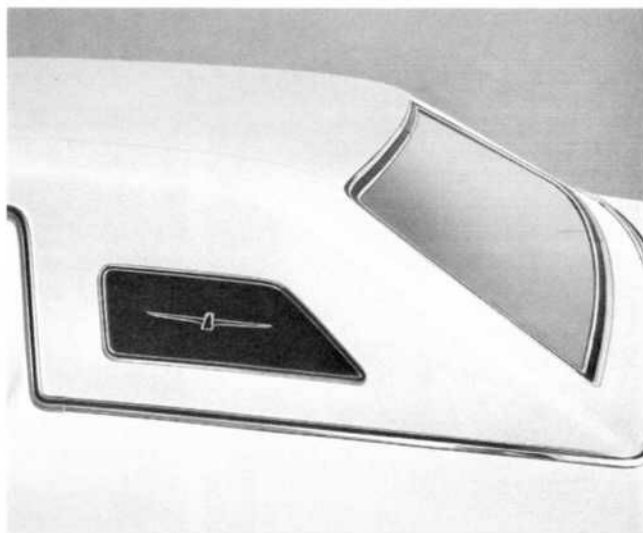

VINYL ROOF AND OPERA WINDOWS

All Thunderbirds have an added touch of elegance with the distinctive vinyl roof and opera windows, both standard for 1974.

The vinyl roof covering in a deeply textured Odense grain is available in Black, White, Blue, Green, Brown, Silver Blue, Gold, Tan and Copper.

The unique trapezoid shape of the standard opera windows complements the profile of the rear pillars.

The addition of the opera window also increases visibility for driver and passengers. A Thunderbird emblem is imprinted in the laminate between two layers of glass and bright inside and outside moldings accent the window.

THUNDERBIRD FEATURES

Body Features (Cont'd)



SPLIT BENCH FRONT SEAT WITH AUTOMATIC SEAT-BACK RELEASES

Thunderbird features split bench seats with independent adjustment of each section and two fold-down armrests. Seating is provided for three persons with the center armrests up. Adjustable head restraints are low for maximum rearward visibility. Standard seat trim features Aurora bodycloth with vinyl facings. A manual reclining passenger seat continues as an option.

For added convenience, an automatic seat-back release has been added as standard equipment. The seat-back release automatically releases both front seat-back latches when either door is opened to facilitate entry into the rear seat, especially when carrying a brief case or packages. A manual release is also provided in the event of an electrical failure or other malfunction.

POWER VENTILATION SYSTEM

A power ventilation system is standard on all Thunderbirds. The system is integrated with the air conditioning/heating system and permits a continuous flow of fresh air into the passenger compartment through registers in the instrument panel.

Air intake is provided by the ram air effect of the car in motion and the four-speed blower. The blower fan operates whenever the heater control selector is in the "Vent" position, providing air flow when the vehicle is temporarily stopped. Air flow can be increased by using higher fan speeds. Moving the heater control selector to the "OFF" position turns the fan off.

The fresh air is distributed throughout the passenger area through adjustable registers. Stale air is routed through the trunk compartment and inner body quarter panels and out through one-way pressure-relief valves in the door lock pillar.

THUNDERBIRD OPTIONS



LIGHT GROUP

This option group provides for both driver and passenger convenience and safety. Included are the Autolamp On/Off Delay System (automatic headlamps on and off), front "lights on" warning light and buzzer, low fuel and door-ajar warning lights, dual overhead map lights integral with dome lamp, engine compartment light and a lighted visor-vanity mirror. Two lights on both sides of the visor-vanity mirror light up when the hinged cover of the mirror is opened.

The new Autolamp automatically turns the headlamps on as darkness approaches and off when daylight returns. The Autolamp unit is activated by positioning the control flag,



THUNDERBIRD OPTIONS

located concentric with the instrument panel light switch, at any position other than Off. In addition to turning the headlamps off and on, the Autolamp also provides for keeping the headlamps and one cornering lamp on for up to 90 seconds, after the ignition has been turned off, and then turning them off. The length of delay can be varied by the Autolamp controls. This added feature should provide enough "safety lighting" to exit the vehicle and enter a residence or building.

GLAMOUR PAINT OPTION

The Glamour Paint option features new colors of the Fire and Starfire deepcluster paint finishes. The special paint creates the illusion of extra depth due to the control and size of aluminum particles in the paint formula. The clarity and transparent characteristics of the highly durable surface is achieved by a final hand-polishing process. Glamour paint finishes are available in Burgundy Fire, Blue Starfire, Silver Blue Fire, Green Starfire, Cinnamon Starfire, Autumn Fire, Gold Fire and Mahogany Starfire. Color-keyed wheel covers are available as a separate option, but only with the Glamour Paint colors.



EXTERIOR DECOR GROUP

This option includes wide protective molding with padded inserts covered in Odense-grain vinyl and color-keyed to the vinyl roof. Also featured are front cornering lamps that provide side illumination when cornering. The cornering lights are integral with the side marker light and cast a beam to the front and side when cornering with headlights on. The light is activated with the turn signal lever and remains on until the turn signal lever returns to its center position. Cornering lamps are also available as a separate option.

TURNPIKE GROUP

This option group is ideally suited for buyers who frequently travel long distances. Included in the option are fingertip speed control, manual reclining passenger seat and trip odometer.

AM/FM STEREO RADIO WITH TAPE PLAYER

This entertainment/sound system provides maximum versatility with three modes of operation—AM, FM and eight-track stereo tape.

The system also features push buttons in the center which can be pre-set to select five AM or five FM stations. Dual front and rear seat speakers are also included, along with controls for manual tuning, front-to-rear balance, volume and tone.

ANTI-THEFT ALARM SYSTEM

A major deterrent to vehicle theft and theft of vehicle contents is the new Anti-Theft Alarm System. The system is armed by locking either door with the key. When armed, the system senses any entry to the passenger or luggage compartment and sounds the horn intermittently for five to seven minutes. NOTE: The system must be disarmed before the trunk lid is opened or the alarm will be activated. Unlocking either door with the key will disarm the system. Once the alarm has been triggered, the system can be deactivated by inserting the key in the ignition and turning it to "on" or "accessory" position. The horn will continue to sound unless deactivated in this manner.

The power for the alarm is supplied by the battery. A locking hood release is included in this option to help prevent tampering with the battery. Two decals, reading "Equipped with Anti-Theft Alarm System," are supplied, and may be affixed at the owner's convenience.

For customer convenience, there is a time delay of approximately ten seconds after arming until the alarm system is activated. This time delay allows sufficient time for all occupants to exit the vehicle.

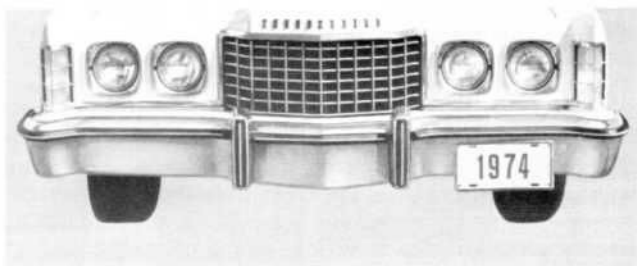

DELUXE BUMPER GROUP

Attractive and functional, Thunderbird's Deluxe Bumper Group is designed to help prevent minor bumper dents and scratches. The option includes a full-width rub strip for the front bumper and rear bumper guards with rubber inserts. New luxury white inserts are included for the bumper and bumper guard rub strips.

APPEARANCE PROTECTION GROUP

The Appearance Protection Group features attractive front and rear color-keyed floor mats with carpet inserts, front and rear license plate frames, bright door-edge guards (deleted when ordered with the Exterior Decor Group), a spare tire cover and bright rocker panel moldings.

THUNDERBIRD OPTIONS

CONVENIENCE GROUP

This new option group combines two driver convenience features: interval windshield wipers and a right-hand remote-control mirror. The interval windshield wipers can be adjusted to provide a pause between each wiping from two to ten seconds, depending on the amount of precipitation, car speed or traffic congestion. The right-hand remote-control mirror can be adjusted by the driver while driving. The control knob is conveniently located on the lower instrument panel to the right of the steering column.



QUICK DEFROST WINDSHIELD/REAR WINDOW

This new option combines an electric rear window defroster and electric-heated windshield that clears the entire front and rear glass area of frost and ice. The heating unit is a specially processed gold film laminate between the two layers of glass for the windshield and backlite. There are no heating circuit wires required, resulting in a transparent laminate with a light gold cast. The unit is controlled by a two-state timer and/or a manual control with a "reminder" light. The two-stage timer reduces the initial heating intensity to one-half the voltage after approximately five minutes, and will run at this new level until the ignition is turned off or the manual switch is switched to off.

SURE-TRACK BRAKE CONTROL SYSTEM

Thunderbird's Sure-Track Brake Control System improves braking stability during maximum braking effort by helping to prevent sustained rear wheel lockup, even on ice or snow. The system becomes important when you remember that sliding or skidding rear wheels may allow the car to spin causing total loss of control, especially if dry pavement is encountered when the car is sliding sideways. During normal braking the majority of the car's weight transfers to the front wheels, unloading the rear wheels and making them prone to locking and skidding. The system has three major components: sensor, control module and an actuator, all of which function to release braking pressure to the skid-prone rear wheels.

The sensor transmits the wheel speed to the control module. The control module analyzes the speed and "commands" the actuator to release brake pressure. The actuator regulates the brake fluid pressure on the rear wheel brakes in a manner to resist wheel lockup. By keeping the rear wheels rolling, directional stability is maintained.

ELECTRIC REAR-WINDOW DEFROSTER

This option helps keep the backlite frost-free and will melt snow, frost, and up to 1/8-inch of ice in a short time. The

heating unit consists of a silver-filled ceramic, high-resistance, printed electrical circuit, silk-screened onto the inside of the backlite. While visible as a series of 1/32-inch wide lines across the full width of the backlite, the unit does not interfere with the driver's rear vision due to the wide spacing between the lines and a subdued, less conspicuous dark red color.

A switch for operating the unit is integral with the heater controls on the instrument panel. Included with this option is a 70-amp alternator and a "reminder" light.

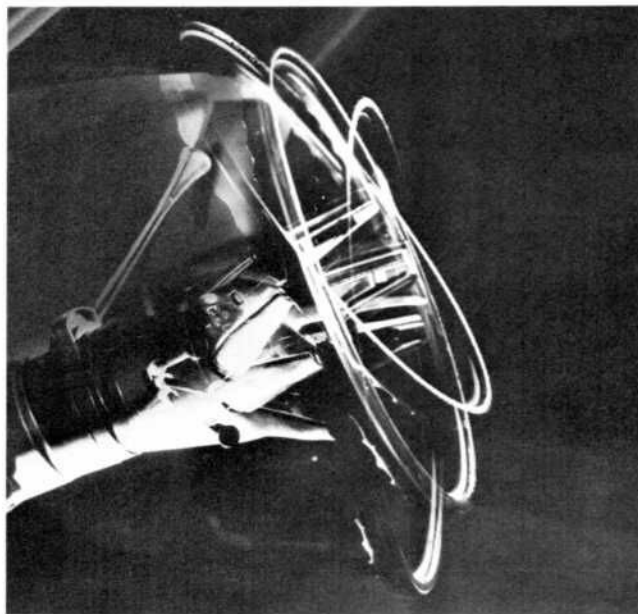

TILT STEERING WHEEL

Thunderbird's Tilt Steering Wheel allows the driver to select any one of five steering wheel angles by pushing forward on the turn signal lever. In entering or exiting the vehicle, it is only necessary to press on the turn signal lever and the wheel "pops" out of the way.

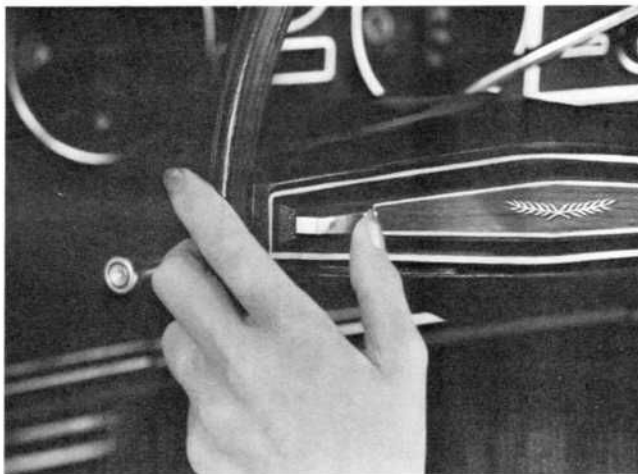

FINGERTIP SPEED CONTROL

The Fingertip Speed Control regulates vehicle speed automatically and maintains a set speed at a desired level, until reset or turned off. The controls are conveniently located in the spokes of the two-spoke steering wheel. Two outboard, spoke-mounted, rocker-type control switches are used to operate this option.

THUNDERBIRD OPTIONS

The left spoke contains the "On-Off" rocker switch. The right spoke contains the "Set-Accel, Coast" rocker switch. By depressing the "On" side of the rocker switch, the system is activated. The driver can accelerate to the desired speed, and by momentarily depressing and releasing the "Set-Accel" switch (left side of the right rocker), the Automatic Speed control will take over at speeds above 30 mph.

The car speed can also be increased by depressing the "Set-Accel" switch and holding it until the desired speed is reached. Release the switch and the control will resume automatic operation at the higher speed.

To lower the speed at which automatic control is desired, the "Coast" switch (right side of right rocker) is pressed and held. When this is done, the car gradually slows down. When a lower speed is reached, the switch is released, and the lower road speed is maintained.

The "Off" switch (left half of left rocker) deactivates the speed control system. This system can also be cancelled by slightly depressing either the brake pedal or by turning the ignition key to "Off." The option includes the "Rim-Blow" deluxe two-spoke steering wheel.

POWER LOCK GROUP

This option combines an electric trunk lid release that is activated by a switch inside the glove compartment and electric power door locks. The electric power door locks are controlled by a convenient switch on each front door armrest eliminating the need to lower or raise the lock button to activate the door locks. Door locks continue to use all-electric operation.

POWER MINI-VENT WINDOWS

This option is all-new for 1974 Thunderbirds. The small, triangular-shaped mini-vent is at the front of the door glass and moves vertically. This design provides a practical venting arrangement without the air noise associated with a conventional pivoting vent window.

To operate the mini-vent, the driver or passenger activates the front power side-window switch. The mini-vent lowers first and can be stopped in any position. When the vent is fully lowered and the switch is held in position, the main window lowers.

POWER SEATS

Six-way power seat controls are located in the driver's "control console" on the driver's door armrest. This luxury option permits easy selection of the most comfortable driving position and the armrest location allows changing position easily while driving. The six-way seat moves up and down—forward and back—and tilts fore and aft. With split bench seats, power can be ordered on driver's seat only or for the driver and passenger's seats. The passenger's control is conveniently located on the right side of the seat.

SELECTAIRE AIR CONDITIONER WITH AUTOMATIC TEMPERATURE CONTROL

SelectAire air conditioning with Automatic Temperature Control allows the Thunderbird owner to control interior comfort during all seasons by setting one control and forgetting it. In warm weather, cooling action begins as soon as the engine is started; in cold weather, heat is delayed until the engine is warm enough to provide good heating action.

When window fogging or icing conditions are encountered, the SelectAire selector is moved manually to the "Defog" or "De-ice" position. Once the glass is clear, the lever may be turned to the automatic position and automatic temperature control takes over again.

The option also includes high and low blower performance levels. Low has five blower speeds and high provides three additional blower speeds to give increased performance for cooling or heating.



POWER-OPERATED GLASS MOONROOF

The new Thunderbird Moonroof is a power-operated sliding glass panel that has the open-air advantages of a convertible . . . the styling features of a hardtop . . . and the privacy of a luxury sedan. When opened, the Moonroof slides down, back, and out of sight on a hidden track between the headliner and roof. When closed, the Moonroof matches the roof-line, and seals tightly in position. The sliding glass panel is unique in that it is made of one-way glass. Passengers can see out even when the panel is in the closed position. To provide complete occupant privacy, an interior manually operated shade is located on a separate track below the glass on the headlining. The glass is available in either a gold or silver tint.

POWER-OPERATED SUNROOF

This popular option allows the Thunderbird owner to achieve the open-air advantages of the convertible and the styling features of a hardtop. The sunroof is powered by an electric motor actuated by a fingertip control above the window. When closed, the sunroof matches the roof line and seals tightly in position. When opened, the sunroof slides down, back, and out of sight on a hidden track between the headliner and the roof.

MANUAL RECLINING PASSENGER SEAT

A reclining passenger seat is available with split bench seats and includes a convenient seat-side control lever. The reclining seat feature is also included in the Turnpike Convenience Group.

SPACE-SAVER SPARE TIRE

This new optional tire is in addition to the standard spare tire. The standard spare tire may be removed and replaced with the space-saver, resulting in additional, usable luggage space. The space-saver spare inflates quickly with the inflation bottle that is included with the option. While the tire is not designed for extended mileage, it does allow for driving at reduced speeds to the nearest service facility for tire repairs.

THUNDERBIRD OPTIONS

"TRACTION-LOK" DIFFERENTIAL

Ford's "Traction-Lok" differential is designed to lock the rear wheels to help eliminate rear wheel spin. The "Traction-Lok" differential provides extra traction on ice, mud or snow, and maximum accelerating power. (See the Power Teams section for more information.)

HEAVY-DUTY TRAILER TOWING PACKAGE

Thunderbird for '74 offers a heavy-duty trailer towing package for Class II and Class III towing (up to 6,000 pounds trailer weight with a maximum tongue load of 700 pounds). The Heavy-Duty Package includes heavy-duty suspension, 70-ampere alternator, transmission oil cooler, extra-cooling package with coolant recovery system, wiring harness, trailer towing plaque and high ratio axle.

(See options listing on page G-14 for component description. See Trailer Towing Warranty Statement on page ii.)

COLOR-KEYED WHEEL COVERS ①

These attractive wheel covers are available in deep-luster Glamour Paint finishes. They are available on Thunderbirds when the Glamour Paint option is ordered.

DELUXE WHEEL COVERS ②

The Thunderbirds feature wheel covers as standard equipment. This deluxe wheel cover is offered as optional and features a finely detailed die-cast, "turbine insert" with a Thunderbird medallion inset at the center.

WIRE WHEEL COVERS ③

New for 1974, these simulated wire wheel covers add an extra touch of glamour to the classic lines of the Thunderbird.

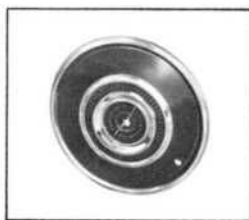

①



②

③

THUNDERBIRD OPTIONS AVAILABILITY

APPEARANCE/PROTECTION EQUIPMENT

Appearance/Protection Group (includes front and rear color-keyed floor mats with carpet inserts, license plate frames, door-edge guards, spare tire cover and rocker panel moldings.) (Door-edge guards deleted when ordered with Exterior Decor Group.)

Alarm System, Anti-Theft (Includes alarm, lockable inside hood release and decals.)

Bumper Group, Deluxe (Includes full-width horizontal rub strip on front and rear bumper; rear bumper guards with rubber inserts.)

Cornering Lamps, Front (Standard with Exterior Decor Group.)

Decor Group, Exterior (Includes unique, wide, lower bodyside protection moldings with padded Odense-grain vinyl insert, partial wheelip moldings, and front cornering lamps.)

Glamour Paint Option

Luggage Compartment Dress-up (Includes carpeting on floor, side lining boards and spare tire cover.)

Paint Stripes, Dual Bodyside and Hood

AUDIO EQUIPMENT

Radio, AM/FM Stereo (Includes two front door-mounted speakers and dual rear seat speakers.)

Radio With Tape Player, AM/FM Stereo (Includes two front door-mounted speakers and dual rear seat speakers.)

COMFORT/CONVENIENCE EQUIPMENT

Air Conditioner—SelectAire with Automatic Temperature Control.

Convenience Group (Includes right-hand outside remote-control mirror and interval windshield wipers.)

Electric Rear Window Defroster (Includes instrument panel indicator light and 70-ampere alternator.)

Light Group (Includes automatic headlamps on and off ("Autolamp"), illuminated vanity-visor mirror, low fuel and door-ajar warning lights, headlamps "on" warning buzzer, dual overhead map lights (integral with dome light, and underhood light.)

Moonroof, Power Operated, Glass

Quick Defrost Windshield/Rear Window

Seat, Manual Reclining Passenger (Standard with Turnpike Convenience Group.)

Space-Saver Spare Tire

Speed Control, Fingertip (Includes rim-blow—deluxe 2-spoke steering wheel.) (Standard with Turnpike Convenience Group.)

Steering Wheel, Tilt

Steering Wheel, Rim-Blow Deluxe 3-Spoke (NA with Fingertip Speed Control.)

Sunroof, Power Operated

Trim, Leather

Trim, Picardy Velour

Trim, Vinyl Seat

Turnpike Group, (Includes fingertip speed control, manual reclining passenger seat, and trip odometer.)

Wheel Covers, Color-Keyed (Available only with Glamour Paint Option.)

Wheel Covers, Deluxe

Wire Wheel Cover, Simulated

POWER ASSISTS

Power Antenna

Power Lock Group (Includes electric power door locks and electric trunk lid release.)

Power Mini-Vent Windows

Power Seat—6-Way Driver Only

Power Seats—6-Way Driver and Passenger

TRAILER TOWING/SPECIAL AND HEAVY-DUTY EQUIPMENT

Axle, Traction-Lock Differential

Battery, Maintenance-Free

Brake Control System, Sure-Track

Dual Exhaust (Includes Sound Package)

Suspension, Heavy-Duty (Includes heavy-duty front and rear springs and heavy-duty front and rear shock absorbers.) (Standard with heavy-duty trailer towing package.)

Trailer Towing Package—Heavy-Duty (Includes heavy-duty suspension, heavy-duty alternator, transmission oil cooler, extra-cooling package with coolant recovery system, wiring harness, trailer towing plaque, and high ratio axle.) (High ratio axle NA California.)

THUNDERBIRD GENERAL SPECIFICATIONS

BRAKE SPECIFICATIONS

Type	Power Front Disc/Rear Drum
Brake Rotor Diameter (Disc)	11.80
Outer Working Surface Diameter	11.80
Inner Working Surface Diameter	6.40
Front Swept Area*	240 sq. in.
Drum Diameter Width	11.03/2.50
Rear Swept Area*	173 sq. in.
Total Front and Rear Swept Area*	413 sq. in.
Lining Material	Molded Asbestos
Lining Attachment	Riveted
Parking Brake-Type	Foot-Actuation of Rear Service Brake, Automatic Vacuum Release

*Swept Area is the effective working surface.

WHEEL SPECIFICATIONS

Type	Stamped Steel, Ventilated Disc with Safety-Type Rim
Number of Studs	5
Diameter and Rim Size (inches)	15 x 6.0

POWER TEAM SELECTIONS

Engine	Cruise-O-Matic Transmission	Rear Axle Ratios		
		Std.	Opt.*	Traction-Lok
460-CID 4V V-8	Standard	2.75 (a)	3.25	2.75 3.25*
460-CID (With Sure-Track)	Standard	2.75 (a)	3.25	2.75 3.25*

ALL RATIOS APPLICABLE TO AIR CONDITIONING.

*Only available with trailer towing package (49 states only).

(a) 3.00 standard California

STEERING SPECIFICATIONS

Linkage Type	Parallelogram with Cross-Link and Idler Arm
Gear Type	Recirculating Ball and Nut with Integral Power Unit
Overall Steering Ratio	21.7 to 1
Steering Gear Ratio	17 to 1
Steering Wheel Turns (lock-to-lock)	4.0
Turning Diameter (curb-to-curb)	43 feet
Steering Wheel Diameter (semi-oval)	15.5 x 15.0 inches

BODY DIMENSIONS

All dimensions in inches unless otherwise noted.

2-Door
Hardtop

GENERAL

Wheelbase	120.4
Tread—Front	63.0
—Rear	63.1
Height—Overall	53.0
Length—Overall	224.8
Width—Overall	79.7
—At center pillar	79.2

FRONT SEAT ROOM

Head room (effective)	37.5
Maximum leg room to accelerator	42.0
Hip room	60.6
Shoulder room	60.4
Cushion depth	15.0
Steering wheel to seat cushion	5.1

REAR SEAT ROOM

Head room (effective)	36.8
Minimum leg room (effective)	36.4
Hip room	54.3
Shoulder room	59.6
Cushion depth	15.2

LUGGAGE COMPARTMENT

Usable luggage capacity (cubic feet)	13.4
--------------------------------------	------

GLASS AREA

Side glass exposed surface area	1413.2
Windshield glass exposed surface area	1326.2
Blacklight glass exposed surface area	815.0
Total glass exposed surface area	3554.4

CURB WEIGHT (pounds)	5068
----------------------	------

THUNDERBIRD COLOR AND TRIM

The charts shown here reflect the many interior and exterior color and trim combinations available for 1974, including Thunderbird's exclusive hand-polished glamour paints. All color names and codes referenced are the same as those shown in the 1974 Color and Trim Book.

EXTERIOR COLORS AND CODE			
Color	Code	Color	Code
Black	1C	Medium Ivy Yellow	6N
Pearl White	9C	EXTRA COST	
Silver Cloud Metallic	1E	GLAMOUR PAINT	
Dark Blue Metallic	3G	OPTION GROUP	
Med. Blue Metallic	3D	Burgundy Fire	2G
Pastel Blue	3A	Silver Blue Fire	3L
Pastel Lime	4A	Blue Starfire	3P
Dark Brown Metallic	5Q	Green Starfire	4Y
Medium Beige	5S	Cinnamon Starfire	51
Buff	5V	Mahogany Starfire	52
Dark Olive Gold Met.	6M	Autumn Fire	5R
Med. Gold Metallic	6L	Gold Fire	6G

STANDARD CLOTH-AND-VINYL		
Interior Trim		Exterior Color Availability Codes
Color	Code	
Black	HA	9C, 1C, 1E, 2G, 3A, 3L, 4A, 4Y, 5R, 5S, 5V, 6G, 6L, 6M, 6N, 52
Med. Blue	HB	9C, 1E, 3A, 3D, 3G, 3L, 3P
Dk. Red	HD	9C, 1C, 1E, 2G
Med. Green	HR	9C, 4A, 4Y
Med. Lt. Tan	HU	9C, 1C, 4Y, 5Q, 5R, 5S, 5V, 51, 52
Med. Saddle	HZ	9C, 5Q, 5R, 5S, 5V, 6G, 51, 52

CLOTH-AND-VINYL OPTION		
Interior Trim		Exterior Color Availability Codes
Color	Code	
Med. Blue	FB	9C, 1E, 3A, 3D, 3G, 3L, 3P
Lt. Tan	FU	9C, 1C, 4Y, 5Q, 5R, 5S, 5V, 51, 52
Lt. Gold	FY	9C, 1C, 4A, 6G, 6L, 6M, 6N

ALL VINYL OPTION		
Interior Trim		Exterior Color Availability Codes
Color	Code	
Black	JA	9C, 1C, 1E, 2G, 3A, 3L, 4A, 4Y, 5R, 5S, 5V, 6G, 6L, 6M, 6N, 52
Med. Blue	JB	9C, 1E, 3A, 3D, 3G, 3L, 3P
Dark Red	HD	9C, 1C, 1E, 2G
Med. Green	JR	9C, 4A, 4Y
Lt. Tan	JU	9C, 1C, 4Y, 5Q, 5R, 5S, 5V, 51, 52
Med. Saddle	JZ	9C, 5Q, 5R, 5S, 5V, 6G, 51, 52
White with Black	JW	9C, 1C, 1E
White with Blue	JQ	9C, 3A, 3D, 3G, 3L, 3P
White with Green	J5	9C, 4A, 4Y
White with Saddle	J9	9C, 5Q, 5R, 5S, 5V, 51, 52
White with Red	JN	9C, 2G
White with Gold	J8	9C, 6G, 6L, 6M, 6N

NATURAL GRAIN LEATHER AND VINYL SEAT TRIM OPTION		
Interior Trim		Exterior Color Availability Codes
Color	Code	
Black	KA	9C, 1C, 1E, 2G, 3A, 3L, 4A, 4Y, 5R, 5S, 5V, 6G, 6L, 6M, 6N, 52
Med. Blue	KB	9C, 1E, 3A, 3D, 3G, 3L, 3P
Dark Red	KD	9C, 1C, 1E, 2G
Med. Green	KR	9C, 4A, 4Y
Lt. Tan	KU	9C, 1C, 4Y, 5Q, 5R, 5S, 5V, 51, 52
Med. Saddle	KZ	9C, 5Q, 5R, 5S, 5V, 6G, 51, 52
White with Black	KW	9C, 1C, 1E
White with Blue	KQ	9C, 3A, 3D, 3G, 3L, 3P
White with Green	K5	9C, 4A, 4Y
White with Saddle	K9	9C, 5Q, 5R, 5S, 5V, 51, 52
White with Red	KN	9C, 2G
White with Gold	K8	9C, 6G, 6L, 6M, 6N

ODENSE GRAIN VINYL ROOF		
Color	Code	Exterior Color Availability Codes
Black*	OA	9C, 1C, 1E, 2G, 3A, 3L, 4A, 4Y, 5R, 5S, 5V, 6G, 6L, 6M, 6N, 52
White	OW	All
Blue	OB	9C, 3A, 3D, 3G, 3L, 3P
Green	OR	9C, 4A, 4Y
Brown	OT	9C, 5Q, 5R, 5S, 5V, 6G, 51, 52
Med. Silver Blue	OE	9C, 3A, 3L
Gold	OY	9C, 4A, 6G, 6L, 6M, 6N
Copper (1974½)	OK	9C, 52
Red (1974½)	OD	2G, 9C, 1C, 1E

*Black NA with Exterior Decor Group.

DUAL PAINT STRIPE OPTION		
Color	Code	Exterior Color Availability Codes
Black	A	9C, 1E, 2G, 3A, 3D, 3L, 3P, 4A, 4Y, 5R, 5S, 5V, 6G, 6L, 6N, 51, 52
Blue	B	9C, 1E, 3A, 3D, 3L, 3P
Red	D	9C, 1C, 1E, 2G, 3A
Gold	G	9C, 1C, 2G, 3G, 3P, 4A, 4Y, 5Q, 6M, 6N, 51, 52
Silver	P	9C, 1C, 3D, 3G, 3P, 4Y
Green	R	9C, 4A
Brown	T	9C, 5R, 5S, 5V, 6G, 6L, 6N, 51, 52
White	W	1C, 1E, 2G, 3D, 3E, 3L, 3P, 4Y, 5Q, 5R, 5S, 5V, 6G, 6L, 6M, 6N, 51, 52
Tan	U	9C, 1C, 2G, 4Y, 5Q, 51, 52

THUNDERBIRD body and chassis features

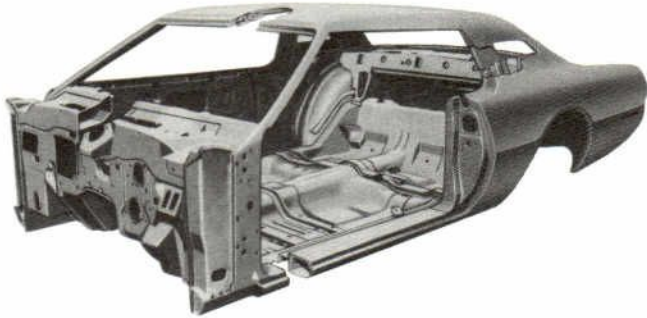

RIGID BODY CONSTRUCTION

Thunderbird's rigid body structure and torque box frame help reduce road shock, noise and vibration for a quiet, comfortable ride.

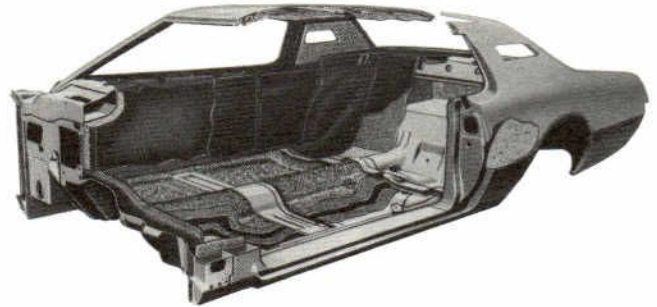

INSULATION AND SOUNDPROOFING

Nine-point insulation and soundproofing effectively reduce engine, transmission, power train and road noises.

THUNDERBIRD SUSPENSION FEATURES

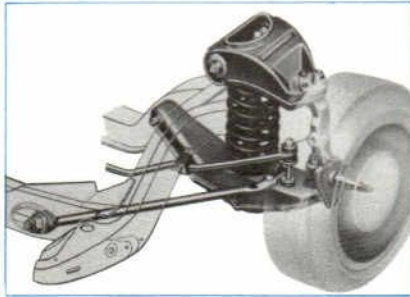

FRONT

Type Independent with Ball Joints and Drag Struts
 Springs Coil, Rubber-insulated
 Shock Absorbers Direct, Double-acting Hydraulic
 Stabilizer Bar Link-type, Rubber-bushed
 Wheel Bearings Taper Roller

REAR

Type Four Trailing Control Arms
 Springs Coil, Rubber-insulated
 Shock Absorbers Direct, Double-acting Hydraulic
 Stabilizer Bar Link-type

SUSPENSION SYSTEM

Thunderbird's "Posi-Ride" rear suspension features a four-link design which provides stability in all recommended conditions of loading. The front suspension features short and long ball-joint arms, plus springs and shock absorbers calibrated to match the weight/ride requirements.

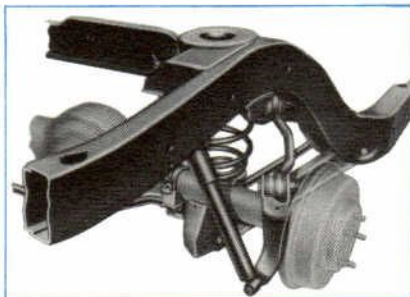

POWER TEAM SELECTIONS

Engine	Cruise-O-Matic Transmission	Rear Axle Ratios		
		Std.	Opt.*	Traction-Lok
460 CID 4V V-8	Standard	2.75 (a)	3.25	2.75 3.25*
460 CID (With Sure-Track)	Standard	2.75 (a)	3.25	2.75 3.25*

ALL RATIOS APPLICABLE TO AIR CONDITIONING

*Only available with trailer towing package (49 states only)
 (a) 3.00 standard California

This year's standard 460 4V V-8 engine features a new Solid-State electronic ignition for stronger spark.



At the time of release, specifications and prices contained herein are believed to be correct. Ford Division reserves the right to discontinue models at any time or change specifications, designs or prices without incurring obligation.

MORE THUNDERBIRD OPTIONS

- AM/FM Stereo Radio
- AM/FM Stereo Radio with Tape Player
- Sure-Track Brake Control System
- Tilt Steering Wheel
- Power Seats
- SelectAire Air Conditioner with Automatic Temperature Control
- Power-Operated Sunroof
- Dual Exhaust System
- Dual Bodyside and Hood Paint Stripes
- Color-keyed Wheel Covers*
- Simulated Wire Wheel Covers
- Deluxe Wheel Covers
- Luggage Compartment Trim

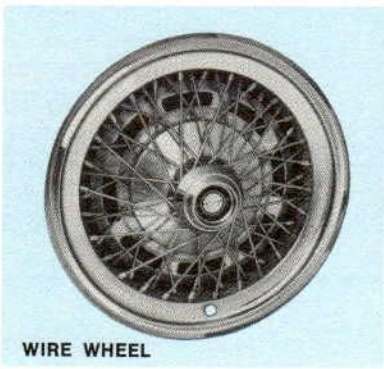
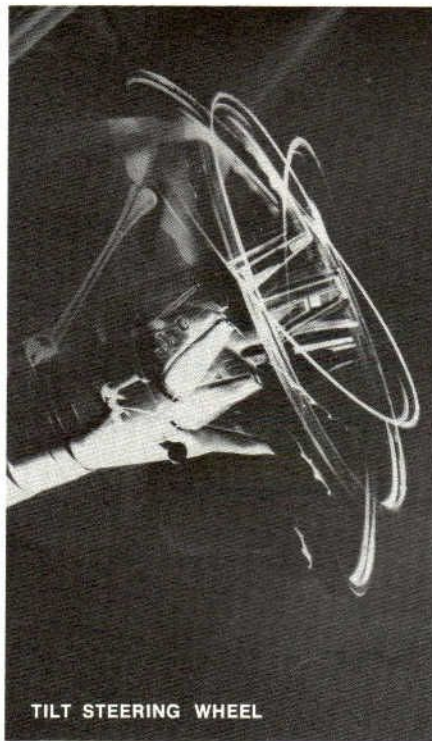

Just a few of the many additional options now available for Thunderbird buyers who want a little something extra.

*Available *only* with Glamour Paint Option