



TORINO . . . The Solid Mid-Size

- Many new standard equipment items for all Torino models! Including:
 - A 351-2V eight-cylinder engine for power and economical operation
 - Solid-State Ignition for improved starting performance and reduced maintenance costs
 - Steel-belted radial ply tires designed for long wear
 - Power steering for easier handling and parking
 - Power front disc/rear drum brakes result in consistent stopping performance
 - Wiper-mounted washer jets

- New Standard equipment on the Gran Torino Sport! Including:
 - Automatic seat back release for easy entry and exit for rear seat passengers

- Torino offers more models — 10 — than any other Ford Division car line!
 - Exceptionally long cruising range is provided by the Torino passenger car 26-1/2 gallon fuel tanks!
 - Torino is an excellent family vehicle because of its rugged perimeter frame, its four-link rear suspension and its wide selection of available engines (351-2V, 400-2V and 460-4V).

TORINO

TORINO INDEX

1975 TORINO MODELS

| | |
|---------------------------------|---|
| MODEL LINE-UP | 2 |
| TORINO | 4 |
| GRAN TORINO | 5 |
| GRAN TORINO BROUGHAM | 6 |
| GRAN TORINO SPORT | 7 |
| TORINO STATION WAGON | 8 |
| GRAN TORINO STATION WAGON | 8 |
| GRAN TORINO SQUIRE WAGON | 9 |

BODY FEATURES

| | |
|---|----------------------|
| Body Construction | 14 |
| Body Insulation | 15 |
| Body Sealing Material | 15 |
| Bumper Jack System | 17 |
| Doors | 16 |
| Doors Handles and Armrests | 16 |
| Fuse Panel | 17 |
| Grille | 17 |
| Guard Rails, Steel | See Section A, p. 10 |
| Heating | 16 |
| Hood | 17 |
| Instrument Panel | 16 |
| Luggage Compartment | 15 |
| Paint Process, Six-Step | See Section A, p. 9 |
| Restraint System, 3-Point Occupant | See Section A, p. 10 |
| Roof, Reinforced | See Section A, p. 10 |
| Rust Protection | 14 |
| Seats | 17 |
| Seat Belt Reminder System | See Section A, p. 10 |
| Ventilation | 17 |
| Windows | 16 |
| Windshield Wipers/Washers | 16 |

CHASSIS FEATURES

| | |
|---|---------------------|
| Brakes, Front Disc/Rear Drum | 14 |
| Brake System | See Section A, p. 6 |
| Bumpers, Energy-Absorbing | See Section A, p. 7 |
| Catalytic Converter | See Section A, p. 9 |
| Frame | 12 |
| SelectShift Cruise-O-Matic | 13 |
| Solid-State Ignition | See Section A, p. 9 |
| Steering Column, Energy- Absorbing | See Section A, p. 6 |
| Steering Column, Locking | See Section A, p. 6 |
| Steering, Power | 13 |
| Front Suspension | 13 |

| | |
|---------------------------------|---------------------|
| Suspension, Rear | 13 |
| Suspension Specifications | 14 |
| Tires | See Section A, p. 8 |
| COLOR AND TRIM | 26,27 |
| MARKET DATA | 3 |

OPTIONS

| | |
|--|-------------------------|
| Complete Listing | 22,23 |
| Anti-Theft Alarm System | 20 |
| Bumper Group, Deluxe | 18 |
| Convenience Group | 20 |
| Door Locks, Electric Power | 18 |
| Defroster, Electric Rear Window | 18 |
| Fuel Monitor Warning Light | 20 |
| Fuel Sentry Vacuum Gauge | 20 |
| Light Group | 21 |
| Manual Passenger Recliner | 19 |
| Metallic Glow Paint | 19 |
| Opera Windows | 21 |
| Radio, AM | 19 |
| Radio, AM/FM Stereo | 19 |
| Radio, AM/FM Stereo with Tape Player | 19 |
| Safety Carrier, Infant | See Section A, p. 14 |
| SelectAire Air Conditioner | 19 |
| SelectAire Air Conditioner With Automatic Temperature Control | 19 |
| Speed Control, Fingertip | 18 |
| Steering Wheel, Tilt | 18 |
| Sunroof, Power Operated | 21 |
| Tot Guard | See Section A, p. 14 |
| Trailer Towing Packages | See Section A, p. 11—13 |
| Vinyl Roof | 19 |
| Vinyl Insert Bodyside Molding | 20 |
| Visor Vanity Mirror, Illuminated | 20 |
| Wheel Cover | 21 |
| Wheel Cover, Deluxe | 21 |
| Wheel Cover, Luxury | 21 |
| Wheel, Magnum 500 Wheel/Trim Rings | 21 |

SPECIFICATIONS

| | |
|-----------------------------------|-------|
| Body Dimensions | 25 |
| Brake Specifications | 24 |
| Power Team Selections | 24 |
| Steering Specifications | 24 |
| Curb Weights | 24 |
| Tire Availability, Standard | 23 |
| Tire Availability, Optional | 23 |
| Wheel Specifications | 24 |
| STANDARD EQUIPMENT | 11,12 |
| STATION WAGON FEATURES | 10 |

TORINO 10 MODELS

TWO-DOOR HARDTOPS (3)

| | Sales Code No. | Body Code No. |
|----------------------|----------------------|---------------------|
| Torino | 25 | 65B |
| Gran Torino | 30 | 65D |
| Gran Torino Brougham | 32 | 65K |



FOUR-DOOR PILLARED HARDTOPS (3)

| | Sales Code No. | Body Code No. |
|----------------------|----------------------|---------------------|
| Torino | 27 | 53B |
| Gran Torino | 31 | 53D |
| Gran Torino Brougham | 33 | 53K |



TWO-DOOR HARDTOP SPORT SERIES (1)

| | Sales Code No. | Body Code No. |
|-------------------|----------------------|---------------------|
| Gran Torino Sport | 38 | 65R |



STATION WAGONS (3)

| | Sales Code No. | Body Code No. |
|-----------------------|----------------------|---------------------|
| Torino | 40 | 71B |
| Gran Torino | 42 | 71D |
| Gran Torino Squire .. | 43 | 71K |





TORINO ... The Solid Mid-Size

- Many new standard equipment items for all Torino models! Including:
 - A 351-2V eight-cylinder engine for power and economical operation
 - Solid-State Ignition for improved starting performance and reduced maintenance costs
 - Steel-belted radial ply tires designed for long wear
 - Power steering for easier handling and parking
 - Power front disc/rear drum brakes result in consistent stopping performance
 - Wiper-mounted washer jets

- New Standard equipment on the Gran Torino Sport! Including:
 - Automatic seat back release for easy entry and exit for rear seat passengers

- Torino offers more models — 10 — than any other Ford Division car line!
 - Exceptionally long cruising range is provided by the Torino passenger car 26-1/2 gallon fuel tanks!
 - Torino is an excellent family vehicle because of its rugged perimeter frame, its four-link rear suspension and its wide selection of available engines (351-2V, 400-2V and 460-4V).

TORINO

TORINO SERIES



MODELS

2-DOOR HARDTOP
4-DOOR PILLARED HARDTOP

SALES NUMBER

25
27



Major Standard Features

EXTERIOR

- High series corrosion-resistant grille with bright and argent segmented design... bright leading edges framed with chrome-plated molding... bright molding around the grille
- Bright headlamp doors
- 114" wheelbase... 2-door models with 213.6" overall length
- Long 118" wheelbase... 4-door models with 217.6" overall length
- Torino ornament on fuel door cover
- Distinctive, dual horizontal headlights
- Energy-absorbing bumper system... 5 MPH front, 5 MPH rear, and 3 MPH corner impact
- Recessed door handles with one-step keyless locking
- 60° windshield and bright reveal moldings around windshield and rear window
- Rear taillights with integral side marker lights
- Frameless, ventless curved side glass
- Bright drip and window moldings
- Bright "Ford" block letters over center of grille and lower deck lid
- Bright "Torino" block letters on front fenders
- Bright hub caps
- Hatch hood



INTERIOR

- Comfortable front bench seats with adjustable head restraints and seat-back locks on folding seat backs
- Attractive, durable all-vinyl seat trim with all-vinyl color-keyed door trim panels
- 12-oz. color-keyed cut-pile carpeting
- Instrument panel with modern, easy-reading instruments... textured metal lower instrument panel color-keyed to interior
- Two-spoke color-keyed energy-absorbing steering wheel
- Glove box with twist lock
- Turn signals with lane-changing feature
- Dome light in center of roof
- Day/Night rearview mirror, vinyl backed and framed
- Illuminated wiper/washer controls
- Luggage compartment mat
- Energy-absorbing armrests
- Sun visor safety padded, left and right
- Suspended accelerator and brake pedals
- Inside hood release

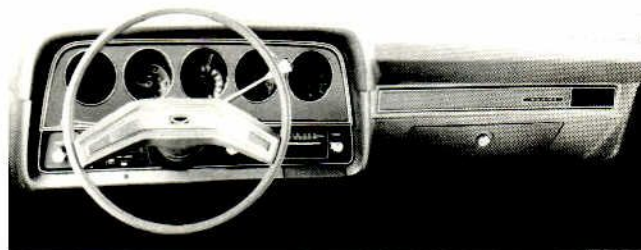

FUNCTIONAL

- 351 CID 2V V-8 engine
- Power front disc/rear drum brakes
- Power Steering
- "DirectAire" ventilation system in all models
- Solid-State Ignition
- Energy-absorbing frame construction
- Recessed windshield wipers, 2-speed electric, with new wiper-mounted washer jets
- HR78x14 steel-belted radial ply BSW tires
- Convenient pin-and-slot bumper jack system
- Heater and defroster with 3-speed blower... illuminated controls
- Body/Frame construction

See page D-11 for a complete list of standard equipment.

GRAN TORINO SERIES



MODELS

2-DOOR HARDTOP
4-DOOR PILLARED HARDTOP

SALES
NUMBER

30
31

Major Standard Features

EXTERIOR

In addition to or in place of features on the Torino Series:

- Gran Torino grille ornament
- Bright wheelip moldings
- Bright rocker panel and rear quarter extension moldings
- Bright "Gran Torino" block letters on front fender
- Gran Torino emblem, with surround wreath, on fuel door cover
- Black paint-filled moldings on lower back panel

INTERIOR

In addition to or in place of features on the Torino Series:

- Plush, deep-pleated cloth-and-vinyl seat trim
- Rear armrests on 2-door models
- High series sound package
- Color-keyed deluxe seat and shoulder belts
- Self-regulating electric clock

FUNCTIONAL

The Gran Torino Series shares many features with the Torino Series. Mutual features include:

- 351 CID 2V V-8 engine
- SelectShift Cruise-O-Matic transmission
- Power front disc/rear drum brakes
- Power steering
- Solid-State Ignition
- Recessed windshield wipers, 2-speed electric, with wiper-mounted washer jets

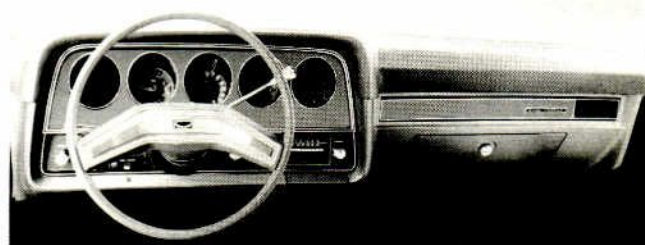

- Heater and defroster with 3-speed blower . . . illuminated controls
- "DirectAire" ventilation system in all models
- HR78 x 14 steel-belted radial ply BSW tires

Additional Features Include:

- Tinted glass — complete

See page D-11 for a complete list of standard equipment.

GRAN TORINO BROUGHAM



MODELS

2-DOOR HARDTOP
4-DOOR PILLARED HARDTOP

SALES
NUMBER
32
33

Major Standard Features

EXTERIOR

The Gran Torino Brougham shares many features with the Gran Torino. Mutual features include:

- High series corrosion-resistant grille with bright and argent segmented design...bright leading edges with chrome-plated molding...bright molding around the grille
- Bright headlamp doors
- Bright wheelip moldings
- Bright "Ford" letters over center of grille and right rear deck lid
- Bright "Gran Torino" block letters on front fenders
- Bright rocker panel and rear quarter extension moldings...front fender extension moldings added for Brougham models
- Black paint-filled moldings lower back panel

Additional features include:

- Brougham stand-up hood ornament
- Opera window...distinctive trapezoid design (2-door models)
- "Brougham" identification on rear pillars (on opera window...2-door models)
- Red reflector lower back panel insert with "Torino" script on die-cast bar
- Wide bright belt moldings (2-door models)
- Full-vinyl roof in: White, Blue, Green, Brown, Tan and Black
- Wide vinyl insert bodyside molding color-keyed to vinyl roof
- Deluxe wheel covers

INTERIOR

In addition to or in place of features on the Gran Torino:

- Split bench front seat
- Luxury Westminster cloth seat trim or no-cost optional super-soft all-vinyl trim
- Dual fold-down center armrests
- Luxury Westminster cloth door trim panels
- Woodtone applique on instrument panel
- Shag carpeting
- Deluxe 2-spoke steering wheel
- Dual note horn
- Soft fiber carpeting in luggage compartment

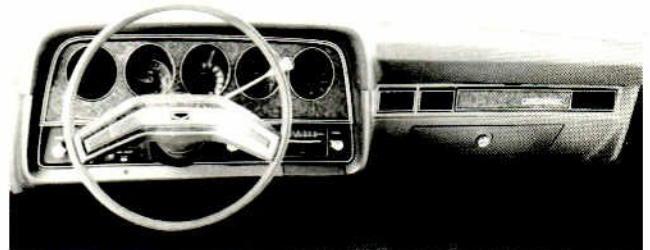

FUNCTIONAL

The Gran Torino Brougham shares many features with the Gran Torino. Mutual features include:

- 351 CID 2V V-8 engine
- SelectShift Cruise-O-Matic transmission
- Power brakes
- Self-adjusting brakes
- Power steering
- "DirectAir" ventilation system
- Recessed windshield wipers, 2-speed electric with new wiper-mounted washer jets
- Solid-State Ignition
- Tinted glass — complete

Additional features include:

- Deluxe sound package
- WSW Steel-belted radial ply tires

See page D-11 for a complete list of standard equipment.

GRAN TORINO SPORT



MODEL

2-DOOR HARDTOP

SALES NUMBER

38



Major Standard Features

EXTERIOR

In addition to or in place of features on the Gran Torino Series:

- "Sport" grille ornament
- Dual fender peak paint stripes
- "Sport" script and crest on rear pillar
- Dual outside color-keyed left-and right-hand remote-control mirrors
- "Sport" ornament on fuel door cover
- "Turbine" wheel covers
- Front fender lower molding
- Wide bright belt moldings
- Full vinyl roof
- Opera windows . . . distinctive trapezoid design

INTERIOR

In addition to or in place of features on the Gran Torino Series:

- Instrumentation group consisting of: tachometer, trip odometer, engine gauges (Oil, Ampere, Temp., Fuel) and electric clock
- Comfortable bucket seats (flight bench seat in lieu of bucket seats . . . no charge RPO)
- Pleated vinyl seat trim
- Plush shag carpeting
- Super-soft vinyl door trim
- "Engine turned" black applique on instrumentation cluster and right-hand panel
- Deluxe 2-spoke steering wheel with woodtone applique
- Automatic seat-back release

FUNCTIONAL

The Gran Torino Sport shares many features with the Gran Torino. Mutual features include:

- 351 CID 2V V-8 engine
- SelectShift Cruise-O-Matic transmission
- Power front disc brakes
- Heater and defroster with 3-speed blower . . . illuminated controls

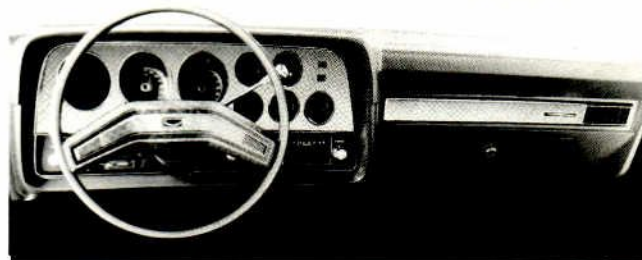

- "DirectAire" ventilation system
- Concealed windshield wipers, 2-speed electric with wiper-mounted washer jets
- High-series sound package
- Power steering
- Solid-State Ignition
- Tinted glass — complete

Additional features include:

- WSW steel-belted radial ply tires

See page D-11 for a complete list of standard equipment.

TORINO AND GRAN TORINO STATION WAGONS



GRAN TORINO



TORINO

MODELS

TORINO 4-DOOR
GRAN TORINO 4-DOOR

SALES
NUMBER

40
42

Major Standard Features

TORINO WAGON

EXTERIOR

- High series corrosion-resistant grille with bright and argent segmented design... bright leading edges framed with bright chrome-plated molding
- Bright headlamp doors
- Long 222.6" overall length
- Bright drip moldings
- Bright quarter window and tailgate window moldings
- Bright "Torino" block letters on lower right corner of tailgate
- Vertical taillamp design with integral backup lights
- Bright "Ford" block letters on black tailgate molding
- Rear bumper guards with rubber inserts

INTERIOR

- Wide 48.2" load space between wheelhousings
- Fold-down second seat for a long load floor length of 87.5" with tailgate up... 109.5" with tailgate down... 84.9 cubic feet cargo volume
- Carpeted load floor area
- Lockable storage compartment under load floor adds 8.1 cubic feet of storage space

FUNCTIONAL

- 351 CID 2V V-8 engine
- Power Steering
- SelectShift Cruise-O-Matic transmission
- Three-Way "Magic Doorgate" — opens horizontally like a door with window up or down... or swings down like an ordinary tailgate
- Manual roll-down tailgate window
- Power front disc brakes
- HR78x14 steel-belted radial ply BSW tires

See page D-11 for a complete list of standard equipment.

GRAN TORINO WAGON

In addition to or in place of features on the Torino Wagon, the Gran Torino offers:

EXTERIOR

- Gran Torino grille ornament
- Bright wheelip moldings
- Bright rocker panel and rear fender extension moldings

INTERIOR

- Self-regulating electric clock
- Plush, deep-pleated vinyl seat trim
- Color-keyed deluxe seat and shoulder belts

FUNCTIONAL

- High series sound package
- Tinted glass — complete

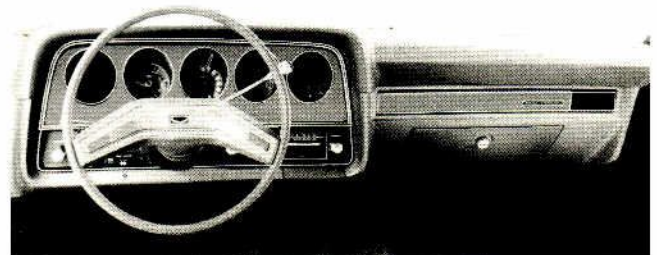

GRAN TORINO SQUIRE STATION WAGON



MODEL

GRAN TORINO SQUIRE 4-DOOR 43

SALES
NUMBER

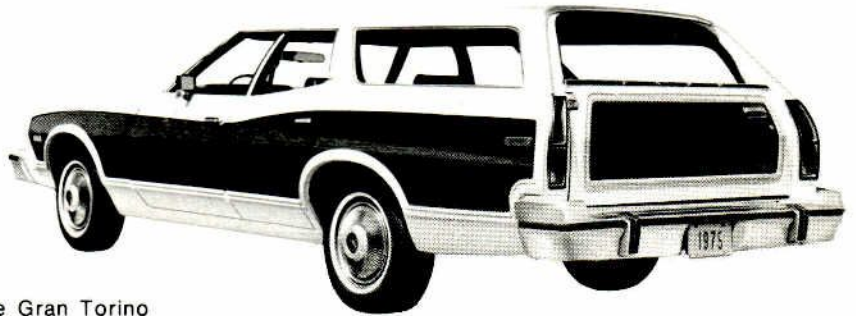

Major Standard Features

GRAN TORINO SQUIRE WAGON

In addition to or in place of features on the Gran Torino Wagon, the Gran Torino Squire offers:

EXTERIOR

- "Color-Match" simulated woodgrain paneling applique on bodyside and tailgate
- Simulated limed-oak woodgrain vinyl-clad aluminum side rails frame "Color-Match" paneling
- Bright "Squire" script on front quarter panels
- Full wheel covers

INTERIOR

- Luxurious vinyl seat trim... color coordinated door trim features with woodtone applique
- Deluxe 2-spoke steering wheel with woodtone applique
- Woodtone applique on instrument panel

FUNCTIONAL

The Gran Torino Squire shares many features with the Gran Torino Wagon. Mutual features include:

- 351 CID 2V V-8 engine
- SelectShift Cruise-O-Matic transmission
- Power front disc brakes
- Power Steering
- Solid-State Ignition
- Tinted glass — complete

Additional features include:

- WSW steel-belted radial-ply tires
- Power tailgate window
- Dual note horn

See page D-11 for a complete list of standard equipment.

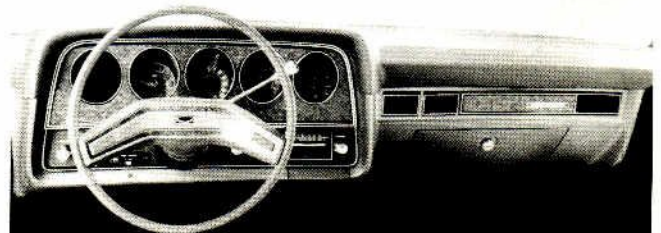
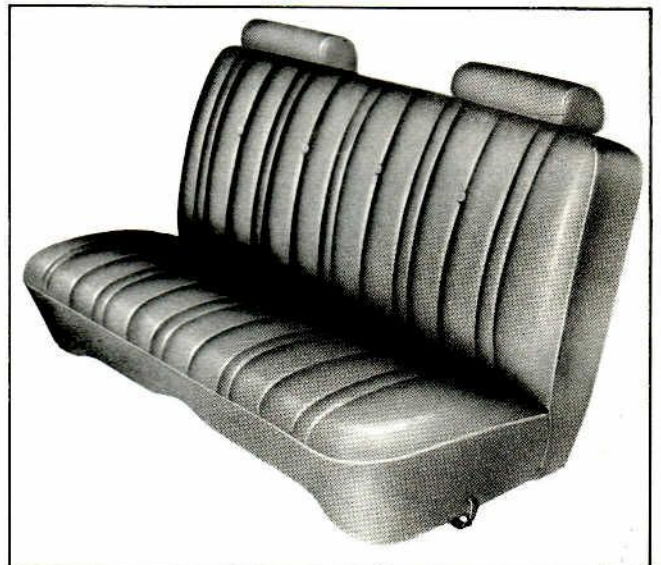

TORINO STATION WAGONS

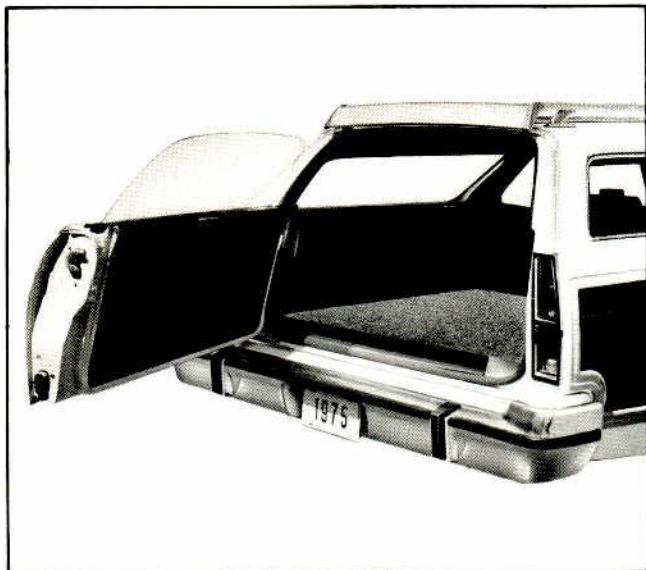

THREE-WAY MAGIC DOORGATE

Torino wagons feature the Three-Way Magic Doorgate that folds down like a tailgate or swings open like a door. When used as a door, the glass can be up or down. A safety interlock system requires that the glass be lowered before the door can be used as a tailgate, and a safety lock button prevents accidental opening of the doorgate. When the button is depressed, the door can be opened only with the key or the optional electric power door locks which include the tailgate lock. All locks are controlled by the lock buttons on the driver and front passenger doors. A power-operated tailgate window is standard on the Gran Torino Squire and optional on the Torino and Gran Torino Wagons.

On all wagons, one easy motion folds the second seat into the floor to provide an 87.5-inch long floor area with the tailgate up.

All load floor panels, including the second seat back, are coated with a special vinyl base paint that resists scuffing and scratching. The floor is covered with color-keyed carpeting.



UNDER-FLOOR STORAGE COMPARTMENT

All Torino Wagons include an extra storage compartment hidden beneath the load floor. This handy compartment is lockable and provides an additional 8.1 cubic feet (5.9 with third seat) of storage space.



SQUIRE BROUGHAM OPTION

For 1975, the Squire Brougham Option adds the touch of luxury to the Gran Torino Squire. Included in this luxury option are: a split bench seat with dual fold-down center armrests, super-soft vinyl inserts and door trim, plush shag carpeting in the passenger compartment, and cut-pile carpet on the load floor. The generous exterior appointments include: deluxe wheel covers and stand-up "Brougham" hood ornament.

DELUXE LUGGAGE RACK OPTION

Torino's deluxe luggage rack features wide, strong, steel side rails highlighted by a glass bead texture finish. The rear crossbar, which is fully adjustable, is attached by brackets to slots in the side rails; it can be moved forward and locked in position when less than full loads are carried. The deluxe rack includes a built-in air deflector with glass bead finish which directs an air stream over the rear window to help prevent the accumulation of dirt deposits.

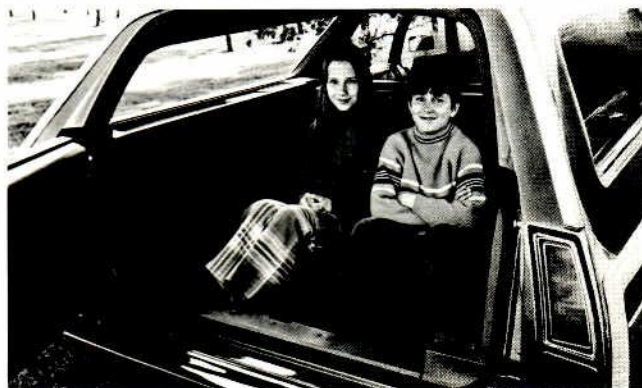

OPTIONAL REAR-FACING THIRD SEAT

The rear-facing third seat provides additional passenger room in the Gran Torino and Squire Wagons. When raised, the seat back locks into an upright position. When closed, the panel may be locked to provide secure storage space.

ELECTRIC REAR WINDOW DEFROSTER

This station wagon convenience option is ideal for cold weather driving, since it is designed to remove small accumulations of ice and snow in minutes. Similar to the rear window electric defroster on other Torino models, it consists of high-resistance electric elements which are silk-screened on the inside of the window. A switch for operating the unit is integrated with the heater controls, and a reminder light indicates when the unit is on. A heavy-duty alternator is included with this option.

TORINO STANDARD EQUIPMENT

| In addition to the standard features listed Torino includes as standard equipment the many Ford Lifeguard Design Safety Features listed on Page A-1. | | | | | | | |
|--|--------|-------------|----------------------|-------------------|--------------|-------------------|--------------------------|
| EXTERIOR | Torino | Gran Torino | Gran Torino Brougham | Gran Torino Sport | Torino Wagon | Gran Torino Wagon | Gran Torino Squire Wagon |
| BUMPERS: Energy-absorbing, front and rear | X | X | X | X | X | X | X |
| CONCEALED WINDSHIELD WIPERS | X | X | X | X | X | X | X |
| HOOD: Counterbalanced, front opening hatch panel | X | X | X | X | X | X | X |
| TAILLIGHTS: Horizontal sec., integral side marker lights, backups center | X | X | X | X | - | - | - |
| Vertical with backups in lower section | - | - | - | - | X | X | X |
| MOLDINGS: Bright drip moldings | X | X | X | X | X | X | X |
| Wheelip moldings | - | X | X | X | - | X | - |
| Door belt moldings | X | X | X | X | X | X | X |
| Rear window bright reveal moldings | X | X | X | X | X | X | X |
| Windshield reveal moldings | X | X | X | X | X | X | X |
| Rocker panel and fender extension molding | - | X | X | X | - | X | - |
| Vinyl insert bodyside molding, color-keyed | - | - | X | - | - | - | - |
| Black tailgate molding | - | - | - | - | X | X | X |
| MIRROR: outside (left-hand) | X | X | X | - | X | X | X |
| Outside, color-keyed left- and right-hand remote-control | - | - | - | X | - | - | - |
| ORNAMENTATION: "FORD" block letters front over center of grille | X | X | X | X | X | X | X |
| "TORINO" block letters on front fenders | X | - | - | - | X | - | - |
| "GRAN TORINO" block letters on front fenders | - | X | X | X | - | X | X |
| "BROUGHAM" identification rear pillar (opera window 2-dr.) | - | - | X | - | - | - | - |
| "SPORT" script and emblem on rear pillar | - | - | - | X | - | - | - |
| "TORINO" block letters lower right tailgate | - | - | - | - | X | X | X |
| "FORD" block letters rear deck lid | X | X | X | X | - | - | - |
| Fuel door cover ornament | X | X | - | X | - | - | - |
| Lower back panel red reflector insert with "TORINO" script | - | - | X | - | - | - | - |
| "SQUIRE" script on front quarter panels | - | - | - | - | - | - | X |
| Stand-up hood ornament | - | - | X | - | - | - | X(a) |
| GRILLE: Bright and argent high-series segmented design | X | X | X | X | X | X | X |
| Identification ornament on grille | - | X | - | X | - | X | X |
| HUB CAPS: stainless steel | X | X | - | - | X | X | - |
| TURBINE WHEEL COVERS | - | - | - | X | - | - | - |
| WHEEL COVERS: full | - | - | - | - | - | - | X |
| WHEEL COVERS DELUXE | - | - | X | - | - | - | X(a) |
| VINYL ROOF | - | - | X | X | - | - | - |
| OPERA WINDOW (2-door) | - | - | X | X | - | - | - |
| PAINT STRIPES: dual fender peak | - | - | - | X | - | - | - |
| SIMULATED WOODGRAIN TRIM ON TAILGATE AND BODYSIDES | - | - | - | - | - | - | X |

INTERIOR

| | | | | | | | |
|---|---|---|---|---|------|------|------|
| ARMRESTS: Energy-absorbing, front and rear on 4-door models. | X | X | X | X | X | X | X |
| Fold-down center armrest (No charge RPO) | - | - | - | X | - | - | - |
| Dual fold-down center armrests | - | - | X | - | - | - | X(a) |
| ASHTRAY: front (not lighted) | X | X | X | X | X | X | X |
| CIGAR LIGHTER: In instrument panel | X | X | X | X | X | X | X |
| CLOCK, ELECTRIC | - | X | X | X | - | X | X |
| COURTESY LIGHTS | X | X | X | X | X | X | X |
| DOOR HANDLES: Inside, Safety design | X | X | X | X | X | X | X |
| Outside, Recessed | X | X | X | X | X | X | X |
| DOOR LATCHES: Safety-yoke type | X | X | X | X | X | X | X |
| BUCKET SEATS | - | - | - | X | - | - | - |
| Split bench front seat | - | - | X | - | - | - | X(a) |
| FLOOR COVERING: Carpet, cut-pile color-keyed | X | X | X | X | X | X | X |
| GLOVE BOX WITH TWIST LOCK | X | X | X | X | X | X | X |
| HEAD RESTRAINTS: Front adjustable | X | X | X | X | X | X | X |
| INSIDE HOOD RELEASE | X | X | X | X | X | X | X |
| INSTRUMENT PANEL: Energy-absorbing, printed instrument cluster circuitry | X | X | X | X | X | X | X |
| Woodtone applique | - | - | X | - | - | - | X |
| MIRROR, INSIDE DAY/NITE REARVIEW | X | X | X | X | X | X | X |
| INSTRUMENTATION GROUP: tachometer, trip odometer (Fuel, Amp., Temp., Oil) black applique | - | - | - | X | - | - | - |
| SCUFF PLATES: aluminum | X | X | X | X | X | X | X |
| SEAT BACK LOCKS: (all folding seats) | X | X | X | X | X(b) | X(b) | X(b) |
| AUTOMATIC SEAT-BACK RELEASE | - | - | - | X | - | - | - |
| LAP BELTS: Front (center passenger) & rear | X | X | X | X | X | X | X |
| RESTRAINT SYSTEM: Driver - front outboard passenger with integral lap and shoulder belts | X | X | X | X | X | X | X |
| COLOR-KEYED SEAT AND SHOULDER BELTS | - | X | X | X | - | X | X |
| STEERING WHEEL: 2-spoke energy-absorbing | X | X | - | - | X | X | X |
| Woodtone 2-spoke energy-absorbing | - | - | X | X | - | - | X |
| STORAGE COMPARTMENT: Below floor with lock | - | - | - | - | X | X | X |
| SUN VISORS: padded | X | X | X | X | X | X | X |
| SUSPENDED PEDALS | X | X | X | X | X | X | X |
| TURN SIGNALS: Lane-change feature | X | X | X | X | X | X | X |

(a)Squire Brougham Option (b)Rear folding seats on stations wagons

Continued on next page

TORINO STANDARD EQUIPMENT (Cont'd)

| In addition to the standard features listed, Torino includes as standard equipment the many Ford Lifeguard Design Safety Features listed on page A-1. | | | | | | | |
|---|--------|-------------|----------------------|-------------------|--------------|-------------------|--------------------------|
| FUNCTIONAL | Torino | Gran Torino | Gran Torino Brougham | Gran Torino Sport | Torino Wagon | Gran Torino Wagon | Gran Torino Squire Wagon |
| BRAKES: Self-adjusting | X | X | X | X | X | X | X |
| Foot-applied emergency brake hand-released | X | X | X | X | X | X | X |
| Power front disc brakes | X | X | X | X | X | X | X |
| ENGINE: | | | | | | | |
| 351 CID 2V V-8 | X | X | X | X | X | X | X |
| DIRECT-AIRE VENTILATION | X | X | X | X | X | X | X |
| HEATER: blend-air type, 3-speed blower | X | X | X | X | X | X | X |
| KEYS: reversible type and keyless door locking | X | X | X | X | X | X | X |
| MUFFLER: aluminized and stainless components | X | X | X | X | X | X | X |
| STEERING, POWER | X | X | X | X | X | X | X |
| TAILGATE: Three-way Magic Doorgate | - | - | - | - | X | X | X |
| TAILGATE POWER WINDOW | - | - | - | - | - | - | X |
| TRANSMISSION: SelectShift Cruise-O-Matic | X | X | X | X | X | X | X |
| WINDSHIELD WIPERS: two-speed electric wiper-mounted washer jets | X | X | X | X | X | X | X |
| DUAL NOTE HORN | - | - | X | - | - | - | X |
| SOLID-STATE IGNITION | X | X | X | X | X | X | X |
| TINTED GLASS — COMPLETE | - | X | X | X | - | X | X |

TORINO FEATURES

Chassis Features

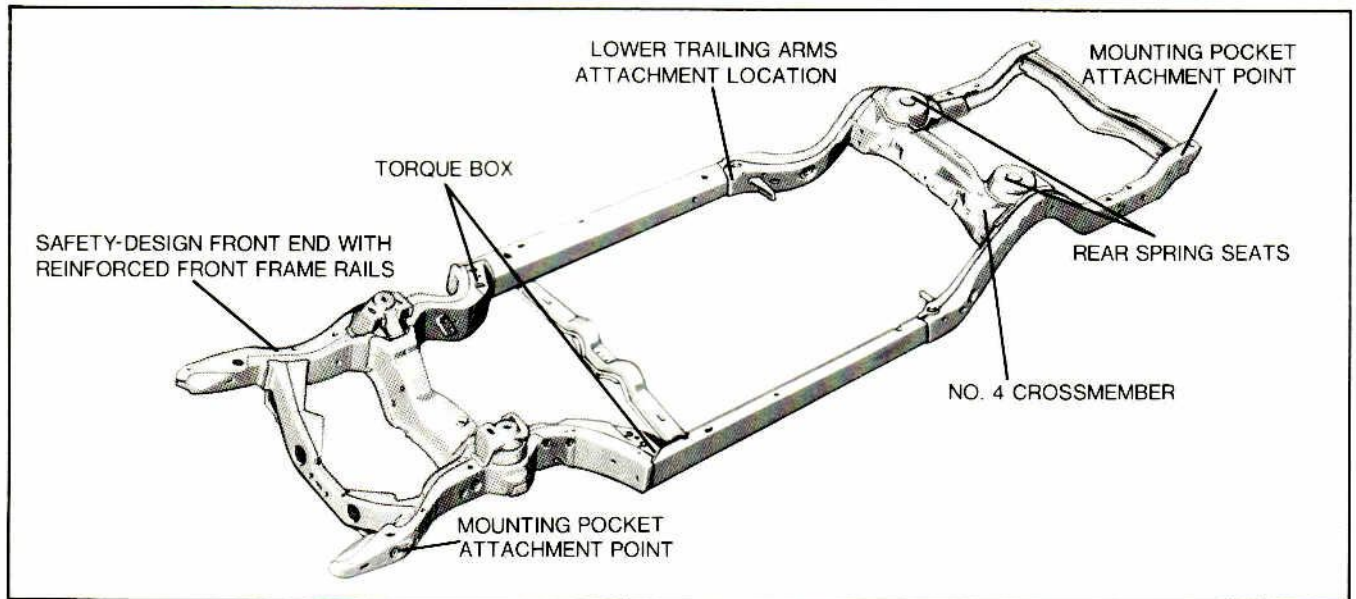

FRAME

The Torino torque box frame is designed to reduce road shocks, thereby providing a smooth, comfortable ride.

Major damageability features of the frame are the reinforced front frame rails and energy-absorbing mechanism of the bumper system.

Features of the design are:

Reinforced outer frame bracing from the front spring pockets to localize the front rail collapse forward of the steering gear and front body mounts.

Reinforced front torque boxes to further localize energy absorption.

The front and rear energy-absorbing bumpers are attached to the frame through mounting pockets, allowing the bumper, impact beam and absorbers to work as a system. This system is capable of sustaining 5 mph front and rear barrier impacts and 3 mph corner impacts without damage to safety-related components. See Section A, page 7, for additional information on energy-absorbing bumper system.

A rugged number four crossmember contains the spring pocket for the coil springs, the mounting holes for the shock absorbers and mounting anchors for the upper two trailing arms.

The frame is reinforced in the kick-up area ahead of the rear axle to anchor the lower trailing arms. The frame construction lends itself to the easy application of trailer hitches.

TORINO FEATURES

SELECTSHIFT CRUISE-O-MATIC

For 1975, all Torino models feature Ford's SelectShift Cruise-O-Matic as standard equipment. This versatile transmission features a choice of automatic or three-speed manual . . . with isolated second gear for use on ice or snow. (See Power Teams section for additional information.)

POWER STEERING

Ford's power steering with power applied directly to the "Magic Circle" gear is standard on all Torino models for 1975. This is similar to the system used in the Thunderbird car line.

Ford Motor Company's power steering pump with "fluidic control" supplies extra power when you need it and coasts at highway speeds. Other features of this power steering system include:

An integral control valve and steering gear design provide instant response to wheel movement. A built-in low restriction control valve allows the wheels to quickly return to center position after making a turn.

A torsion bar element in the steering shaft provides driver "feel" of the road.

A 21.8 to 1 overall steering ratio provides responsive handling with light steering effort.

(See page D-24 for steering specifications.)

FRONT SUSPENSION

For 1975 Torino's suspension continues to be a short and long arm type with the coil springs mounted on the lower arm. This clears the engine compartment of space-robbing spring towers. The "30,000-mile lub." ball joints are continued. Springs and shock absorbers are tuned to match the weight/ride requirements of each application depending on the car model, engine selection and optional equipment. Front suspension features include:

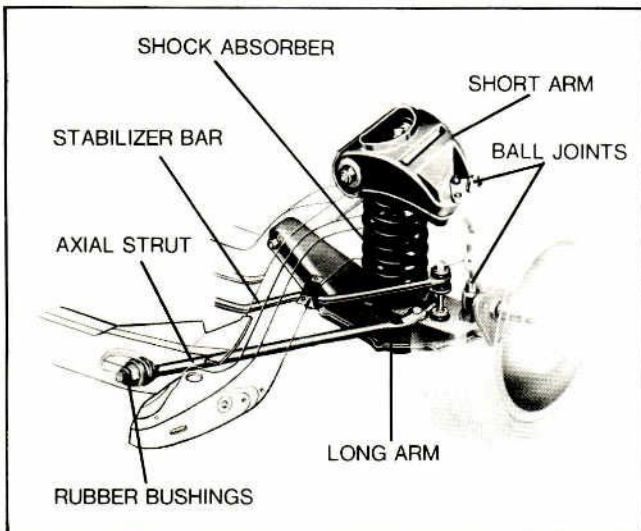

Left and right axial struts stabilize the lower arms and are attached to the frame through rubber bushings to eliminate metal-to-metal contact. The compliant rubber bushings reduce the amount of road disturbance transmitted to the passenger area and allow the wheels to move slightly toward the rear when hitting a bump. This controlled rear movement soaks up part of the initial road shock before it reaches the passenger area.

A link-type, rubber-bushed stabilizer bar connects the right-and left-hand lower suspension arms to help prevent excessive lean when cornering.

REAR SUSPENSION

Torino uses a four-link "Stabil" rear suspension system which improves stability of the car in either loaded or unloaded conditions. The coil springs, as in the front suspension, help provide an exceptionally smooth ride. Features of the system include:

Four longitudinal arms control the position of the rear axle assembly and absorb braking and accelerating forces.

The lateral location of the axle is maintained due to the arrangement of the arms. The lower arms are splayed inward from their attachment and the short upper arms are splayed outward placing the assembly under tension laterally. This arrangement gives the car strong directional stability and resistance to side-to-side body shake on rough roads.

Coil springs ride in deep rubber-insulated caps in the frame and are seated on the axle.

The arrangement of the control arms tends to help stabilize the vehicle in roll.

Shock absorbers are mounted at an angle to provide as wide a base of control as possible.

An optional heavy-duty/handling suspension is available. See options, page D-23.

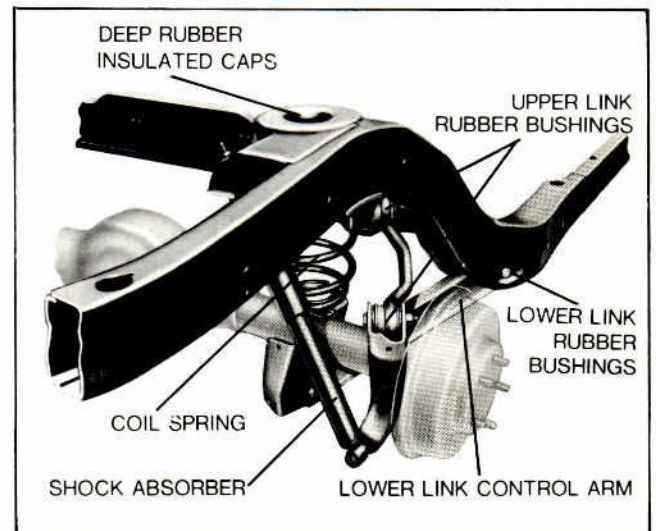

TORINO FEATURES

TORINO SUSPENSION SPECIFICATIONS

FRONT

| | |
|----------------------|--|
| Type | Independent with Ball Joints and Drag Struts |
| Springs | Coil, Rubber-Insulated |
| Stabilizer | Link-Type, Rubber-Bushed |
| Wheel Bearings | Taper Roller |

REAR

| | |
|-----------------------|---------------------------------|
| Type | Four Trailing Control Arms |
| Springs | Coil, Rubber-Insulated |
| Shock Absorbers | Direct, Double-Acting Hydraulic |

POWER FRONT DISC/REAR DRUM BRAKES

Power front disc brakes and rear drum brakes are standard on all Torino models. See Page A-6 for additional description of disc brakes. All sedans, excluding station wagons, have 10 x 2-1/2-inch rear brakes, while on station wagons, the rear brake size is 11 x 2-1/4-inch.

Torino's brakes are self-adjusting. Self-adjustment for rear brakes is accomplished, if needed, when the brake is applied when the car is moving in reverse. Front disc brake pad adjustment is maintained by the piston "O"-ring.

Torino's parking brake is mechanically applied by a convenient foot pedal and is released by a handle below the instrument panel.

BODY FEATURES

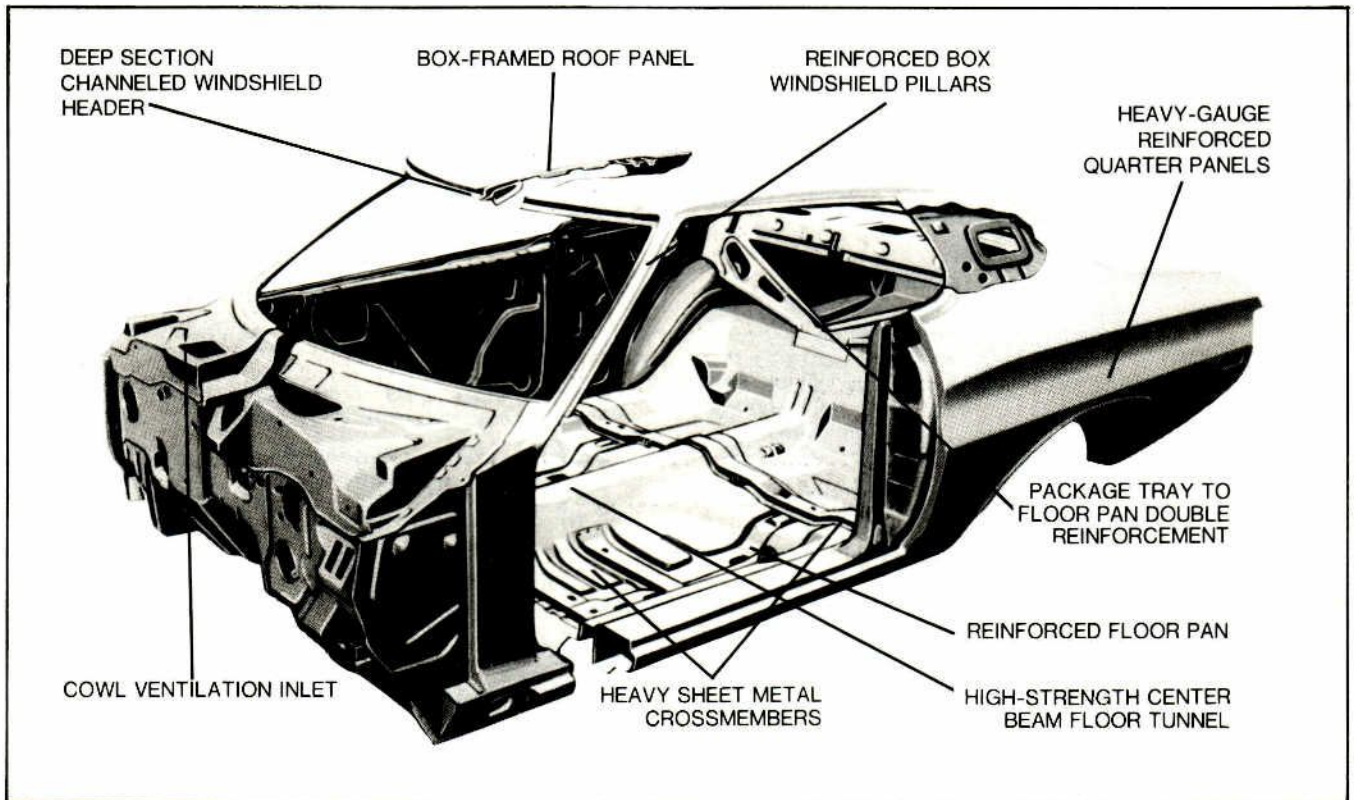

BODY CONSTRUCTION

The 1975 Torino bodies and the torque box frames are designed to work together to help reduce road shock, noise and vibration, and the amount being transmitted to the passenger compartment. Features of the Torino body construction are:

A rigid body construction coupled with the compliant mounting to the torque box frame results in effective insulation of the passengers from noise, vibration and harshness.

A reinforced, double-panel construction rocker panel which is further strengthened by a U-channel section acts as a secondary frame support to the body.

Cowl ventilation air inlets at the top sides — directly below the windshield — permit structural continuity to be built into the cowl top and down the side pillars. All center pillars are manufactured from heavy gauge steel.

Additional body reinforcements in station wagon bodies provide added rigidity.

RUST PROTECTION

All vital underbody parts of Torinos have been processed to resist corrosion. Door outer panel inner surfaces are coated with a zinc-rich primer and inner panels are stamped out of Zincrometal 34 Aluminum wax is sprayed in the bottom of the door assemblies. The quarter panel and fender interior surfaces are sprayed with zinc-rich primer. Rocker panels are made of zinc-clad steel and have one-way drain valves to reduce moisture accumulation. Separate front wheelhouse panels help protect fender areas. Both quarter panel and wheelhouse are treated with aluminum wax along the lower periphery. The trunk lid has a 4" band of zinc-rich primer along its trailing edge. Front, middle and rear pillars have expanding sealer in their weld joints

Sheet metal with zinc coating.

TORINO FEATURES

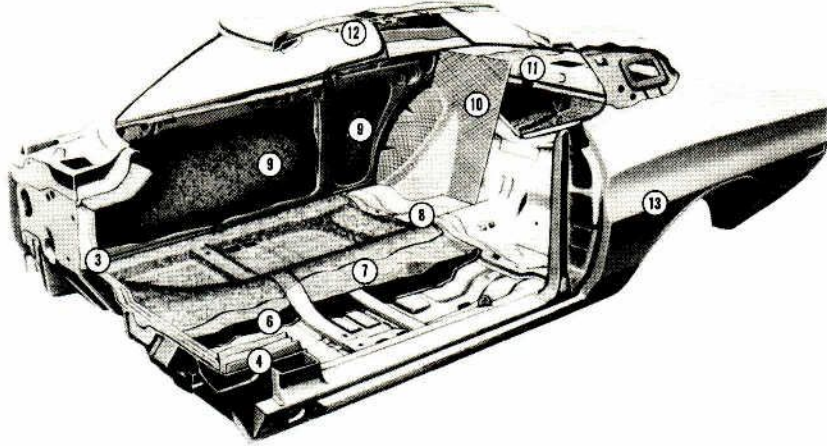

BODY INSULATION

The insulation and soundproofing package in the 1975 Torino provides an effective sound barrier to reduce road and engine noise.

- (1) The hood has mastic adhesive spotted between the inner and outer panel construction. Gran Torino, Gran Torino Brougham and Squire models have a one-inch fiberglass pad on the underside of the hood.
- (2) Front fenders have a sound-deadening coating sprayed on inner housings, including fender openings. Side seals have been added between the front fender inner reinforcement and the cowl sides.
- (3) The dash absorber construction on the Torino consists of a 1/2" thick fiber pad, a one-pound mastic barrier and a 1/2" thick fiber pad covered with a polyethylene skin.
- (4) Cowl side panels consist of a one-pound mastic sheet and a 1/4" fiber pad with crepe side cemented to sheet metal on Gran Torino, Brougham and Squire models. A 1" 3-pound fiberglass absorber with 16-gram neoprene coating is attached from the fender to cowl side baffles. Cowl top is insulated with a 3/4" fiber pad.
- (5) The cowl top panel on the Gran Torino, Brougham and Squire models has a 1/2" fiber pad.
- (6) The front floor area on all Gran Torinos, Gran Torino Broughams and Gran Torino Squires has two layers of one-and-a-half-pound mastic sandwiching a layer of 42-gram fiber pad. A thick jute pad is also bonded to the floor covering. All other models have a layer of one-pound mastic plus the jute pad.
- (7) The insulation used on the rear floor is the same as that used on the front floor.
- (8) Under the rear seat is 1/4" thick fiber pad and one-pound mastic sound-deadener on Gran Torinos, Gran Torino Broughams and Gran Torino Squire models.
- (9) Door and quarter panels have sprayed-on sound deadener on the inner surface of the outer panels.
- (10) All two-door and four-door Hardtops use a two-ply felt pad back of the rear seat.
- (11) The package tray is insulated with a foam absorber.
- (12) Roof panels and rear pillars are insulated with 3/8" fiber pads. Rear pillar insulation consists of 3/16" fiber pad, a chip board barrier and another 3/16" fiber pad covered with a polyethylene skin.

- (13) Rear wheelhouse splash areas are sprayed with sound-deadener coating.

Station Wagons also have insulation over the quarter wheelhouses, rear floor over axle, rear floor sides and deep well.

BODY SEALING MATERIAL

Following are some of the joint sealers and special anti-squeak sealing devices used in the Torino to help assure a comfortable, quiet ride.

Special plastic sealing material applied to exposed spot-welded panel seams and joints.

Vinyl-plastic sealer used at the drip rails and rear deck trough.

Windshields are sealed with butyl tape.

A special non-drying plastic seal is used in conjunction with the weatherstrip on all backlites.

Special pads, grommets, seals and plug buttons guard against water, dust and drafts.

Heat-curing sealer applied to all other panel seams and joints.

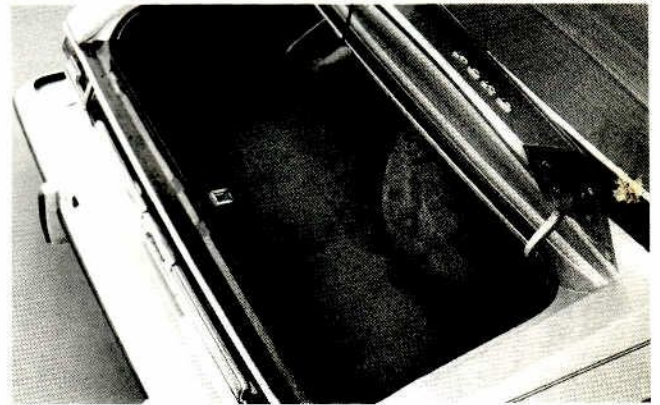

LUGGAGE COMPARTMENT

The usable luggage capacity in Torino Pillared Hardtops and two-door Hardtops is 16.5 cubic feet. Neoprene rubber weatherstripping helps provide protection against dirt and moisture. Optional luggage compartment trim is available for all Torino passenger cars. Included in this option is carpeting, side lining boards and a spare tire cover.

TORINO FEATURES

WINDSHIELD WIPERS/WASHERS

Concealed windshield wipers are standard on all Torino models. The hood panel extends rearward and upward to cover the wiper blades and arms in the parked position. The bottom edge of the windshield extends downward for wiper blade parking.

The left wiper arm is articulated to improve the wiper pattern. The wipers are driven by a powerful two-speed electric motor.

Windshield washer jets are mounted to the wiper arm. The washer nozzle is located halfway up the wiper arm and sprays the washer fluid behind the blade on the up-stroke and ahead of the blade on the down-stroke, enabling the last wiper stroke to wipe away the previous application of fluid. This design helps reduce the problems of overshoot and undershoot, and disperses the fluid over the entire sweep area of the blade.

WINDOWS

Side and backlite windows, on all 1975 Torino models, are high-strength, impact-resistant, heat-tempered glass. The windshield is constructed of two sheets of glass which are sandwiched to a 30-mil thick plastic sheet and heat-laminated together. This type of windshield construction provides strength and pliability, which enables the windshield to take "stretch under impact" minimizing injury-producing penetration.



DOORS

Torino doors are formed into a sturdy box unit by using a double-panel welded construction. Bronze-bushed hinges are used for long wear and easy opening and closing. The lower hinges incorporate assist springs to aid in opening the door and to retard slamming when closing. All front doors incorporate check straps to provide an intermediate door check position to aid entry and exit when the car is parked in close quarters.

Bear-hug door latches increase rattle resistance and provide easy opening and secure closing operation. They also help protect against accidental opening on impact. All side doors also feature a steel "Guard Rail." See Side Impact Protection System, page A-10.

DOOR HANDLES AND ARMRESTS

Torino's exterior handles are pull-out type, recessed in the door surface. An unframed depression in the door panel provides finger room.

One-step locking is standard on all side doors. The doors may be locked from the outside by simply depressing the inside door lock control button, and then closing the door.

The inside door pull handle is formed as an integral part of the armrest. The operating handle is a "paddle-shape" and actuates the door latch when pulled outward with the fingertips. The design provides protection against accidental opening by passengers.

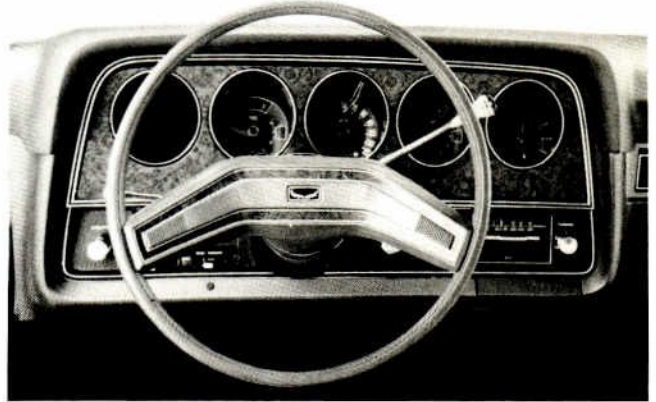

INSTRUMENT PANEL

The 1975 Torino Instrument Panel construction utilizes both steel and plastic to provide energy-absorbing capability. Plastic is framed on sheet metal and covered by a one-piece injection molded energy-absorbing facing with a leather-like vinyl texture. The vinyl pad is color-keyed to the trim selection. A large glove box with a molded door and safety-type twist open latch is placed on the right side.

The control panel in front of the driver contains a row of pods which house the following:

The center pod is the speedometer. The next left pod contains the fuel gauge, left turn signal, high beam and alternator warning light. The pod to the right of center houses the temperature gauge, brake warning system light, the oil pressure warning light and the right-hand turn signal. The extreme left-hand pod is the DirectAire ventilating duct and the right-hand pod is a provision for the standard electric clock on the Brougham models or an optional electric clock on other models.

On Gran Torino Sport models an instrumentation group is standard. This feature includes a tachometer, trip odometer and the following engine gauges: FUEL, AMPERE, TEMP. and OIL. An electric clock is also included.

The section of the panel on the left of the steering-column contains the light switch and heater controls. The illuminated windshield wiper/washer switch and radio are to the right. The ashtray with cigar lighter is below the radio.

HEATING

Torino's high-capacity heater uses the blend-air principle of temperature control. Temperature is controlled by regulating the amount of air that passes through the heater core.

Heat, defrost, and temperature controls, and the three-speed blower switch are located under the front edge of the instrument cluster within easy reach of the driver. The defroster lever ducts air to slit-type openings on the instrument panel to defog the windshield.

TORINO FEATURES

DIRECTAIRE VENTILATION

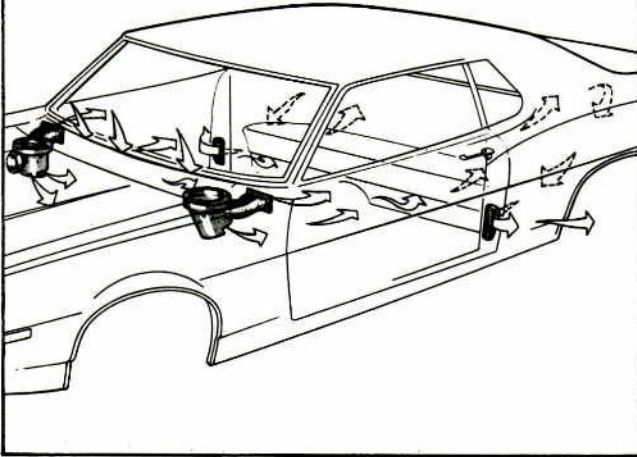

VENTILATION

Standard in all Torinos is DirectAire ventilation. This system provides air flow through the vehicle with the windows closed. The DirectAire system provides for both high and low outlets in the front compartment and Flow-Thru pressure relief one-way exhaust valves in the door lock pillars.

With "DirectAire," two fully adjustable air registers, one in each end of the instrument panel, are used. Also there are two outlets directed toward the toe board. These are the same registers as are used with the optional SelectAire air conditioning system. Air flow from the registers can be adjusted by rotating the barrel on the left or by moving the louvers on the right side of the instrument panel, or by directing the register up or down. The air can be shut off by moving the louver control to the extreme right. The distribution of air can also be controlled between the panel registers and the floor directed outlets by a pull rod.

With this ventilation system, air can enter from the concealed front intakes . . . circulate throughout the interior . . . and exit, carrying away stale or smoke-laden air . . . without any need to open a window.

FUSE PANEL

A fuse panel, located on the passenger compartment firewall to the right of the brake support, is designed to hold eleven fuses. This permits the maximum number of circuits used per fuse to be two, increasing overall electrical system reliability. The extra fuse location also simplifies diagnostic testing of the electrical system.

HOOD

All Torinos feature a hatch-type hood that is designed at the front to blend into the new sheet metal over the grille. Counterbalanced double-link hinges make the hood easy to open and close. Heavy coil springs assist in raising the hood and holding it open.

Rubber bumpers provide cushioning against squeaks and rattles. The bumpers are adjustable for leveling the hood with the front fenders and sheet metal over the grille.

As an anti-theft measure, all Torino models feature an inside hood release as standard equipment. The release handle is below the left side of the instrument panel. Pulling the handle partially opens the hood which then permits access to an outside safety latch which must be released before the hood can be fully opened.

BUMPER JACK SYSTEM

The 1975 Torinos are equipped with a pin-and-slot bumper jack system. The design eliminates the hook that normally connects to the bottom of the bumper. Instead, a flat pin, integral with the ratchet mechanism, fits into slots pierced into the bumper. The system provides faster, simpler operation with more positive retention.

GRILLE

The grille used on all Torino models is bright and dark argent and features an oval, eight segmented design with an inner eggcrate pattern.

Parking/turn signal lamps are behind the grille at the far outboard edges. The Gran Torino and Gran Torino Sport ornament is located left of the center of the grille. On Gran Torino Brougham and Gran Torino Squire (with Squire Brougham option) models, the Brougham ornament is located on the hood and is mounted with a spring-loaded fold-back device.

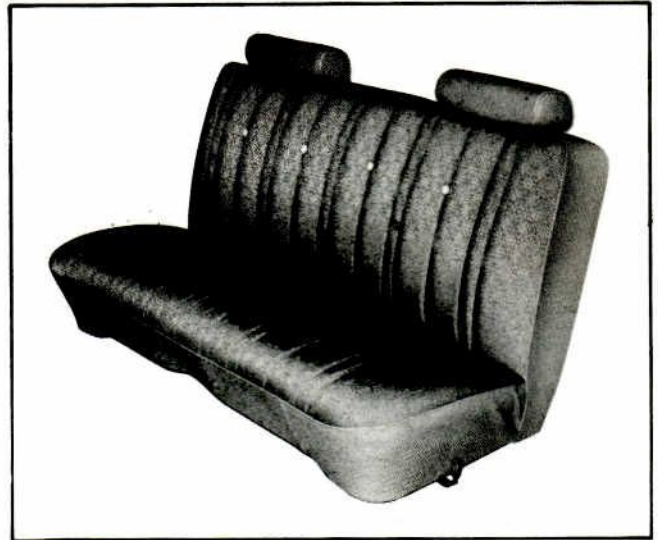

SEATS

Gran Torino Brougham models feature comfortable individually adjustable split bench seats with dual fold-down center armrests. These style seats include full-width head restraints. On Torino and Gran Torino models, seats are the low-back bench design with low-profile head restraints. Gran Torino Sport features bucket seats with full-width head restraints as standard while flight bench seats are available at no extra cost.

Seat springs are attached to a rugged welded frame foundation. A burlap pad with interwoven wires is placed over the springs to provide a strong, yet smooth base for the seat padding. Front seats are covered with a molded urethane foam pad and rear seat cushions are constructed of extra heavy layers of cotton, except station wagons, which have a cotton and foam padding combination.

TORINO OPTIONS

Torino offers a wide variety of factory-installed options which are described here in detail and/or listed on pages D-22,23. Owners can select from these items to equip their cars to suit their personal tastes.

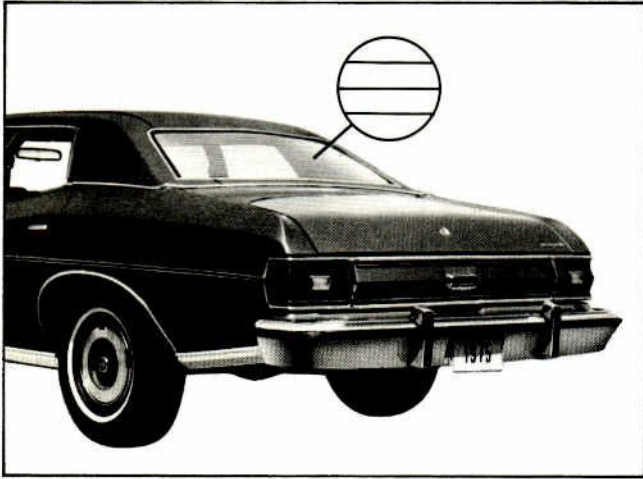

ELECTRIC REAR WINDOW DEFROSTER

Optional on all Torino models, the heated backlite quickly defogs the glass and melts ice and snow. The heating unit consists of a silver-filled ceramic, high resistance printed electrical circuit, silk-screened onto the inside of the backlite. While visible as a series of 1/32-inch wide, horizontal lines across the backlite, the unit does not interfere with the driver's rear vision due to the wide spacing between the lines.

An "Accessory" switch for operating the unit is located with the heater controls on the instrument panel. The option includes a "reminder" light which indicates when the unit is "on." A heavy-duty, higher output alternator is also included.

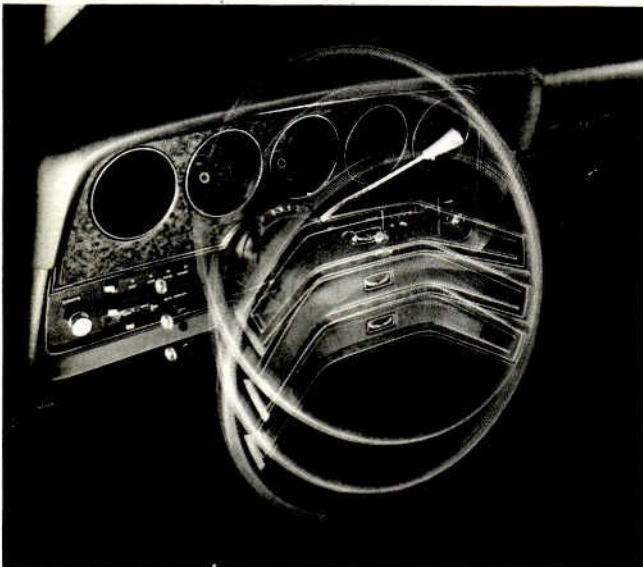

TILT STEERING WHEEL

Torino's optional Tilt Steering Wheel allows the driver to select any one of five steering wheel angles by pushing forward on the turn signal lever. The wheel can be placed in the maximum "up" position for easy entry/exit.

ELECTRIC POWER DOOR LOCKS

This convenience option features all-electric operation. The front door lock buttons actuate switches connected to electric motor-driven servos in the doors. Raising either button unlocks all doors and lowering either button locks all doors. On station wagons, this option also includes a power lock for the doorgate.

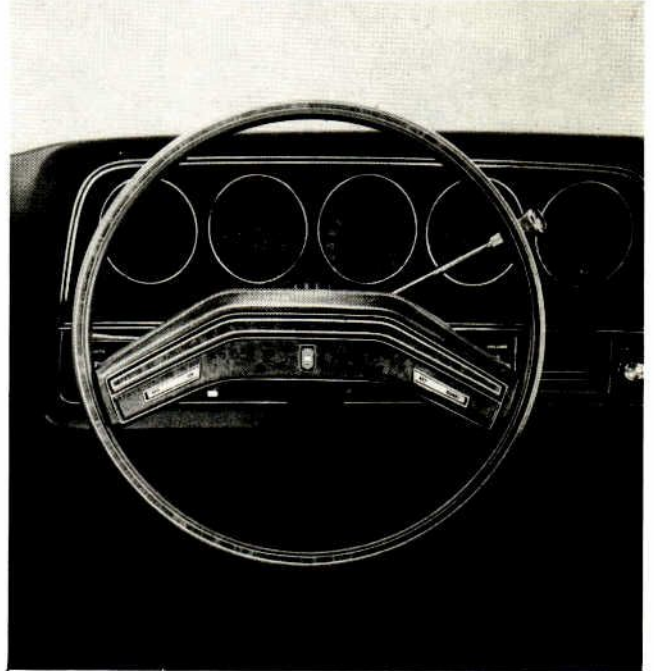

FINGERTIP SPEED CONTROL

The Fingertip Speed Control option regulates vehicle speed automatically and maintains a set speed at a desired level, until reset or turned off. The controls are conveniently located in the spokes of the two-spoke steering wheel.

The left spoke contains the "On-Off" rocker switch. The right spoke contains the "Set-Accel, Coast" rocker switch.

By depressing the "On" side of the rocker switch the system is activated. The driver can accelerate to the desired speed and by momentarily depressing and releasing the "Set-Accel" switch, the Automatic Speed control will take over at speeds above 30 mph. The car speed can also be increased by depressing the "Set-Accel" switch and holding it until the desired speed is reached. Release the switch and the control will resume automatic operation at the higher speed.

To lower the speed to which automatic control is desired, the "Coast" switch (right side of right rocker) is pressed and held. When this is done, the car gradually slows down. When a lower speed is reached, the switch is released, and the lower road speed is maintained.

The "Off" switch (left half of left rocker) deactivates the speed control system. This system can also be cancelled by slightly depressing the brake pedal or by turning the ignition key to "Off."

DELUXE BUMPER GROUP

Attractive and functional, Torino's optional Deluxe Bumper Group helps prevent minor dents and scrapes to front and rear bumpers. The option includes full-width rub strip on the front and rear bumpers and durable scratch-resistant front and rear bumper guards with vertical rub strips (rear bumper guards standard on wagon models). Two additional bumper guard options are also available.

TORINO OPTIONS



AUTOMATIC TEMPERATURE CONTROL AIR CONDITIONING

Automatic Temperature Control with SelectAire air conditioning is available on all models except 2- and 4-door Torino models and the Torino station wagon. This option allows the Torino owner to control interior comfort during all seasons, by setting one control and forgetting it. In warm weather, cooling action begins as soon as the engine is started; in cold weather, heat is delayed until the engine is warm enough to provide good heating action, except on "defrost."

When window fogging or icing conditions are encountered, the SelectAire selector is moved manually to the "Defog" or "Defrost" position. Once the glass is clear, the lever may be turned to the automatic position and automatic temperature control takes over again.

A separate fan switch selects one of two automatic speed ranges: a high and low range, and a maximum blower (fan) speed. There are eight fan speeds used to maintain automatic temperature control. LOW has four speed ranges, which are generally used when the outside air is moderate. HI provides four additional fan speeds, which might be required when the outside air is considerably colder or warmer than the temperature selected for the car interior. In both LOW and HI, the best fan speed for the temperature condition is selected automatically. The maximum fan speed (MAX) is only for extreme heating and cooling requirements.

SELECTAIRE AIR CONDITIONING

The Torino SelectAire air conditioning unit, including controls, is fully integrated into the instrument panel and provides temperature and humidity controlled comfort with all windows closed.

The four-speed blower motor and two air conditioning positions give this unit maximum versatility. By placing the select lever on "A/C," air is circulated through vents in the instrument panel. A "HI/LO" position directs air through both the instrument panel vents and floor vents. A temperature control lever enables the operator to select the desired temperature.

AM RADIO

Torino's solid-state AM Radio option features reliable circuitry and excellent reception. Included is a whip antenna that resists breakage.

AM/FM STEREO RADIO

Torino's AM/FM stereo radio includes a circuitry with high sensitivity for retaining weak signals. The AM/FM stereo radio allows a choice of AM or FM stereo reception merely

by moving the function selector switch. Stereo multiplex operation is indicated by an amber light on the radio faceplate. A "5 x 10" push button feature allows the five push buttons to be preset to provide five AM and five FM stations. Balance and fader controls allow exact blending of sound from the four-speaker system. Two front speakers (one in each front door) and two package-tray-mounted rear speakers are included with the AM/FM stereo radio.

AM/FM STEREO RADIO WITH TAPE PLAYER

A complete entertainment/sound system, the AM/FM stereo radio with tape player, offers three modes of operation, AM, FM and tape. Four speakers provide true stereo reproduction and excellent sound clarity and tonal range. The tape segment of the unit accepts the popular eight-track cartridges. Insertion of the tape cartridge automatically shuts off the radio. Controls are provided for manual tuning, front-to-rear balance, volume, tone, and push-button radio selection.

METALLIC GLOW PAINT

Four optional "Metallic Glow" paints are available on the 1975 Torino in Green Glow, Ginger Glow, Tan Glow and Silver Blue Glow. These paints create the illusion of extra depth due to the control and size of the aluminum particles in the special paint formula. The clarity and transparency of the highly durable surface also contribute to the distinctive characteristics of these glamorous finishes.

VINYL ROOF

This option adds to the luxury appearance of Torino and provides a "customized" color-keyed accent to interior and exterior color and trim combinations. Standard on the Gran Torino Brougham, the vinyl roof is available in six colors on all other models except wagons. (See page D-26 for vinyl roof trim combinations.)

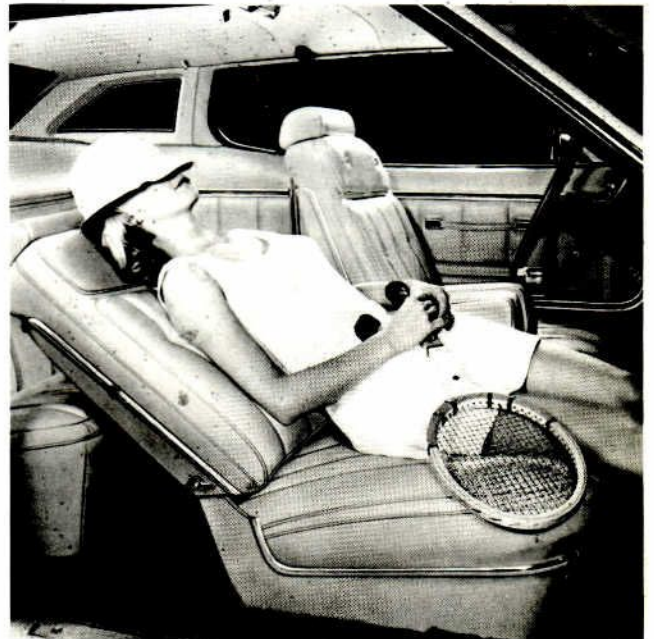

MANUAL PASSENGER RECLINER

This option provides the ultimate in seating comfort. It is available with the Gran Torino Brougham, and Gran Torino Squire with the Squire Brougham option. The seats are individually adjustable and the passenger seat has a recliner that can be adjusted to any desired position.

TORINO OPTIONS

ANTI-THEFT ALARM SYSTEM

A major deterrent to vehicle theft and theft to vehicle contents is the optional Anti-Theft Alarm, available on all Torino models.

The system utilizes a solid-state electronic device, and when armed, senses any entry to the passenger or luggage compartment.

A switch attached to the front door lock-tumbler provides the method of arming and the electronic device provides the functions of sensing voltage differentials, activation, sounding the horn, timing, automatic shut-down and deactivation.

The system can be armed by locking either front door with the appropriate key. Once the system has been armed, opening any of the doors, trunk lid or station wagon doorgate will activate the alarm. NOTE: The system must be disarmed before the trunk lid or doorgate can be opened or the alarm will be activated. Unlocking either front door, with the proper key, will disarm the alarm. Once the alarm has been triggered, the system can be deactivated by inserting the key in either front door and turning to the unlock position. It can also be deactivated by inserting the key into the ignition and turning it to the "on" or "accessory" position. The system will continue sounding the horn intermittently for five to seven minutes unless it is deactivated in this manner.

Also included is a lockable inside hood release and a spare tire lock. These items are included in the Security Lock Group which is also available as a separate option.



ILLUMINATED VISOR VANITY MIRROR

This new option is available on all models. When the hinged cover of the mirror is opened, two lights on either side of the visor vanity mirror light up, thus providing added passenger convenience.

VINYL INSERT BODYSIDE MOLDING

Attractive and functional, this option is designed to help protect bodyside sheet metal from scratches and minor dents. Vinyl inserts are black. When ordered in combination with the Squire Brougham option, vinyl inserts are brown. Gran Torino Brougham models feature bodyside moldings with wide, color-keyed vinyl inserts as standard equipment.

CONVENIENCE GROUP

This group option combines popular features for driver and passenger comfort and convenience. Included are: left and right-hand remote-control mirrors that allow easy adjustment of either mirror from the driver's seat. The front visor vanity mirror offers special passenger convenience. Interval windshield wipers reduce smearing and dry-wiping in periods of light rain, mist or car spray. They can be adjusted to wipe at intervals up to ten seconds.

For station wagon owners, a Spare Tire Extractor is included. It provides a convenient method of removing the spare tire from the wheel well in the right rear quarter panel. The extractor consists of a plastic sling, which is underneath the tire and fastened at the front of the spare tire well with a handle at the rear. Pulling up and to the left on the handle lifts the tire out of the well and onto the load floor.

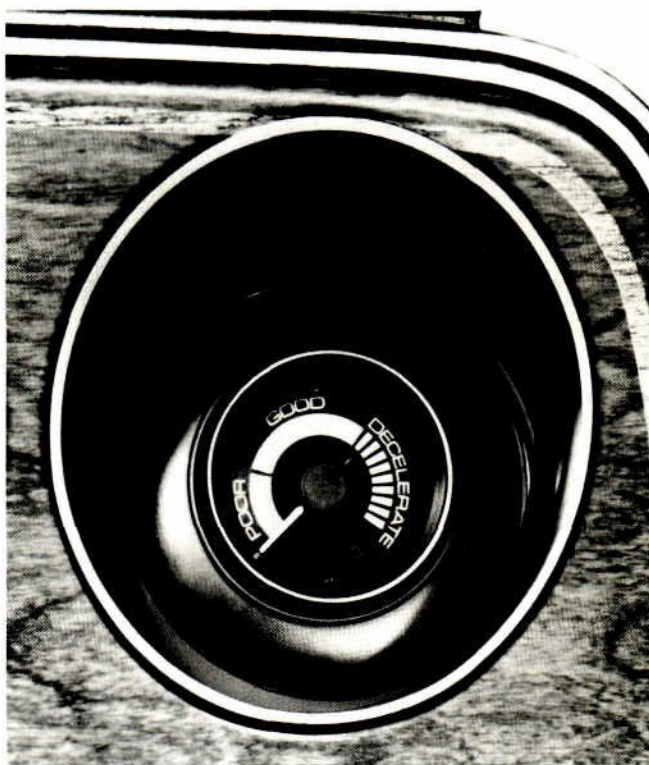

FUEL SENTRY VACUUM GAUGE

The Fuel Sentry Vacuum Gauge is available as a factory installed option on all Torino models with the 351 CID 2V engine except Gran Torino Sport.

The Fuel Sentry Vacuum Gauge monitors the engine vacuum inside the intake manifold and transmits this data to the dial on the gauge face. The face of the gauge is divided into red and green bands (Excellent and Good - green; Poor - red). By keeping the needle in the green (Good or Excellent), the driver can alter his driving habits and begin obtaining the best gas mileage possible.

Fuel Sentry is mounted in the clock cluster housing. When installed on the Gran Torino Brougham or the Gran Torino Squire, with the Squire Brougham option, the electric clock is deleted and a credit is issued on the purchase of the Fuel Sentry.

FUEL MONITOR WARNING LIGHT

The Fuel Monitor Low Vacuum Warning Light has been designed to help the driver achieve improved gasoline economy by visually signaling when excessive fuel is being used. It is available on all Torino models with all engine applications. The Fuel Monitor Warning Light is connected to a device which monitors engine vacuum in the intake manifold. When engine vacuum is low, the amber warning light is illuminated, indicating excessive fuel consumption. The warning light will go "out" when the driver reduces pressure on the accelerator pedal.

Through the use of the Fuel Monitor Warning Light, the driver can change his driving habits and avoid "jack-rabbit starts" and excessive high-speed mileage.

TORINO OPTIONS

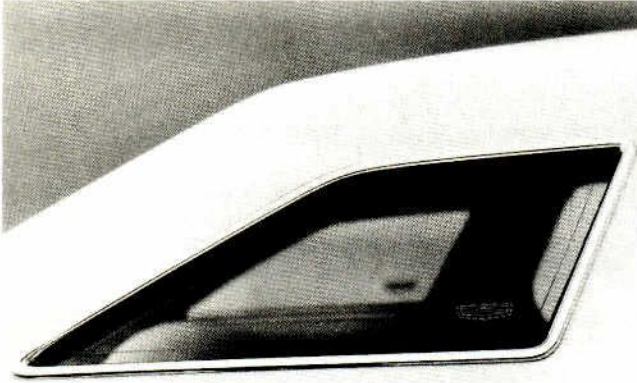

OPERA WINDOWS

This trapezoid-shaped window is standard on the 2-door Gran Torino Brougham and available on the Gran Torino Sport and the 2-door Gran Torino. The addition of the opera window increases visibility for drivers and passengers and helps complement the profile of the rear pillar.

LIGHT GROUP

Torino's Light Group includes a convenient dual beam map light unit in the roof. Two individually activated miniature map lights on either side of the dome light shine over the shoulders of driver and front seat passenger. Other features of the Light Group include ashtray light, glove compartment light, luggage compartment light (cargo light on station wagons), instrument panel courtesy light, engine compartment light, rear door courtesy light switches (4-door models), headlights "lights on" warning buzzer, parking brake warning light, and headlight switch illumination.



POWER-OPERATED SUNROOF

A power-operated sunroof, located over the front compartment, is available on all 2-door Torino models with the optional vinyl roof and provides the open-air advantages of a convertible with the styling and security of a hardtop. The sunroof is powered by an electric motor which is actuated by a finger tip control in the roof and slides back out of sight above the headliner. When closed, the sunroof matches the roofline and seals tightly in position, keeping the weather and noise outside.

BASE WHEEL COVER

This rust-resistant full wheel cover is standard on Gran Torino Squire. It is available as an option on all other models except Gran Torino Sport and the Gran Torino Brougham.



DELUXE WHEEL COVER

The deluxe wheel cover is standard on the 1975 Gran Torino Brougham models, and with the Squire Brougham option. It is available as an option on all other models, except Gran Torino Sport.



LUXURY WHEEL COVER

The luxury wheel cover is available as an option on all models.



MAGNUM 500 WHEEL/TRIM RINGS

The 14" Magnum 500 wheel with chrome trim rings is available as an option on all models except station wagons, and models equipped with fender skirts.



TORINO OPTIONS AVAILABILITY

APPEARANCE/PROTECTION EQUIPMENT

ACCENT GROUP, TORINO - includes wheelip moldings and dual accent paint stripes. Available only on Torino series 2-door and 4-door models.

ALARM SYSTEM, ANTI-THEFT - includes door, hood and trunk alarm, spare tire and inside hood release lock.

BELTS, DELUXE COLOR-KEYED - available only on Torino Series Models - standard elsewhere

BUMPER, GROUP, DELUXE — includes front and rear bumper guards with rubber inserts and full width horizontal rub strips on bumpers.

BUMPER GUARDS, FRONT - includes rubber inserts. Required in states of California, Maryland, Georgia and North Carolina, except when deluxe bumper group is ordered.

BUMPER GUARDS, REAR - includes rubber inserts. Standard on station wagon models.

FENDER SKIRTS - available only on Gran Torino, Gran Torino Brougham, and Gran Torino Sport hardtop and pillared hardtop models. Not available with magnum 500 wheel/trim rings.

LUGGAGE COMPARTMENT TRIM - includes carpeting, side and rear lining boards and spare tire cover. Not available on station wagon models.

MOLDINGS, VINYL INSERT BODYSIDE - includes black vinyl insert (brown vinyl insert on Gran Torino Squire). Wide color-keyed molding standard on Gran Torino Brougham models.

PAINT, METALLIC GLOW - available in silver blue glow, green glow, ginger glow, and tan glow.

PAINT STRIPES, DUAL ACCENT - standard on Gran Torino Sport model and with accent group. Not available on station wagon models.

PROTECTION GROUP - includes front color-keyed floor mats, door edge guards, and bright license plate frames. Door edge guards are deleted when ordered on Gran Torino Squire model.

ROOF, VINYL - standard on Gran Torino Sport and Gran Torino Brougham models. Not available on station wagon models.

SECURITY LOCK GROUP - includes lockable inside hood release, spare tire lock, and locking gas cap.

SQUIRE BROUGHAM OPTION - includes deluxe wheel covers, stand-up hood ornament, split bench front seat, super-soft vinyl seat/door trim, and shag carpeting. Available only on Gran Torino Squire model.

STEERING WHEEL, LEATHER-WRAPPED - not available with fingertip speed control.

WHEEL COVERS - standard on Gran Torino Squire model. Not available on Gran Torino Sport and Gran Torino Brougham models, or with Squire Brougham Option or Exterior Decor Group.

WHEEL COVERS, DELUXE - standard on Gran Torino Brougham model, and with Squire Brougham Option.

STEERING WHEEL, LUXURY - standard with fingertip speed control.

WHEEL/TRIM RINGS, FIVE MAGNUM 500 - not available on station wagon or with fender skirt option.

WINDOWS, OPERA standard on Gran Torino Sport and Gran Torino Brougham 2-door hardtop model. Available only on 2-door Gran Torino. Requires vinyl roof at extra cost.

AUDIO EQUIPMENT

RADIO, AM

RADIO, AM/FM STEREO - includes two front door-mounted speakers and dual rear seat speakers.

RADIO, WITH TAPE PLAYER, AM/FM STEREO - includes two front door-mounted speakers and dual rear seat speakers.

SPEAKERS, DUAL REAR SEAT - standard with AM/FM stereo radio with or without tape player. Available only with AM radio.

COMFORT/CONVENIENCE EQUIPMENT

AIR CONDITIONER, SELECTAIRE - tinted glass-complete recommended.

AIR CONDITIONER, SELECTAIRE WITH AUTOMATIC TEMPERATURE CONTROL - not available on Torino series. Tinted glass - complete recommended.

CLOCK, ELECTRIC - available only on Torino Series - standard elsewhere.

CONSOLE - available only on Gran Torino Sport model equipped with bucket seats. Includes floor shift except when ordered with tilt wheel.

CONVENIENCE GROUP - includes left-hand and right-hand chrome outside remote-control mirrors, visor vanity mirrors and interval windshield wipers. Station wagon models also include spare tire extractor. Left- and right-hand chrome outside remote-control mirrors deleted when this option ordered with outside color-keyed remote-control mirrors.

ELECTRIC REAR WINDOW DEFROSTER - required in state of New York (except on station wagon models).

GLASS, TINTED — COMPLETE - available only on Torino Series - standard elsewhere.

LIGHT GROUP - includes ashtray light, dual beam map light, glove compartment light, luggage compartment light, cargo light on station wagons, instrument panel courtesy light, engine compartment light, rear door, courtesy light switches on 4-door models, headlights "lights-on" warning buzzer, headlight switch illumination, and parking brake warning light.

LUGGAGE RACK, DELUXE - includes integral rear window air deflector and adjustable rear crossbar. Available only on station wagon models.

MIRROR, ILLUMINATED VISOR VANITY

MIRRORS, OUTSIDE COLOR-KEYED REMOTE-CONTROL - includes left-hand and right-hand remote-control mirrors. Standard on Gran Torino Sport model. Not available with special paint (DSO or PTO).

MIRROR, OUTSIDE LEFT-HAND CHROME REMOTE-CONTROL - not available on Gran Torino Sport model or models with outside color-keyed remote-control mirrors. Standard in Convenience Group.

SEAT-BACK RELEASE, AUTOMATIC - standard on Gran Torino Sport model. Available only on 2-door models.

SEAT, MANUAL RECLINING PASSENGER - available on Gran Torino Brougham, and Gran Torino Squire model with Squire Brougham Option.

SEAT, REAR-FACING THIRD - available only on Gran Torino and Gran Torino Squire station wagon models.

SPEED CONTROL, FINGERTIP - includes luxury two-spoke steering wheel.

STEERING WHEEL, TILT

SUNROOF, POWER-OPERATED - available only on 2-door models. Requires vinyl roof at extra cost.

TRIM, DURAWEAWE VINYL - available on Gran Torino and Gran Torino Squire station wagon models. Not available with Squire Brougham Option. Available in tan, blue and green.

TRIM, PLEATED VINYL BENCH SEAT - standard on Gran Torino and Gran Torino Squire Station Wagon models. Available only on Gran Torino hardtop or pillared hardtop models.

TRIM, SUPER-SOFT VINYL - standard with Squire Brougham Option. Available only on Gran Torino Brougham models at no extra charge.

TORINO OPTIONS AVAILABILITY

ENGINES

400 CID 2V 8-CYLINDER — includes 68 amp. heavy-duty battery

460 CID 4V 8-CYLINDER — includes 68-ampere heavy-duty battery.

EMISSION EQUIPMENT, CALIFORNIA — required in state of California.

WARNING LIGHT, FUEL MONITOR

VACUUM GAUGE, FUEL SENTRY—available only with 351 CID 2V engine. N.A. Gran Torino Sport.

SPECIAL HEAVY-DUTY EQUIPMENT

AXLE, OPTIONAL RATIO

AXLE, TRACTION-LOK DIFFERENTIAL

SUSPENSION, HEAVY-DUTY HANDLING — wagons include heavy-duty rear springs. Hardtops and pillared hardtops include heavy-duty rear springs, larger front stabilizer bar and rear stabilizer bar. Standard with trailer towing packages.

TRAILER TOWING PACKAGE, CLASS II—includes heavy-duty handling suspension, high ratio axle (except with 460 CID engine) extra-cooling package, wiring harness, and rear

bumper trailer towing identification plaque. Station wagons require HR78 x 14 6-ply rated tires at extra cost.

TRAILER TOWING PACKAGE, CLASS III — includes heavy-duty alternator, heavy-duty frame (except station wagon models), wiring harness, heavy-duty handling suspension, extra-cooling package, coolant recovery system, trailer towing identification plaque, and external transmission oil cooler. Requires 460 CID 4V engine at extra cost. Station wagons require HR78 x 14 6-ply rated tires at extra cost.

POWER ASSISTS

POWER DOOR LOCKS, ELECTRICAL — includes power tailgate lock on wagons.

POWER SEAT, 6-WAY DRIVER ONLY — available only with Gran Torino Brougham, and the Gran Torino Squire with the Squire Brougham Option.

POWER SEAT, 6-WAY FULL WIDTH — not available on Gran Torino Brougham models.

POWER SIDE WINDOWS — includes front windows only on 2-door models.

POWER TAILGATE WINDOW — standard on Gran Torino Squire model. Available only on station wagon models.

TORINO GENERAL SPECIFICATIONS

1975 TORINO STANDARD TIRE AVAILABILITY

| MODEL AND ENGINE APPLICATION | 351 CID 2V 8-CYLINDER | 400 CID 2V 8-CYLINDER | 460 CID 4V 8-CYLINDER |
|-----------------------------------|--------------------------|--------------------------|--------------------------|
| TORINO | | | |
| 2-Door Hardtop | HR78 x 14 BSW | HR78 x 14 BSW | HR78 x 14 BSW |
| 4-Door Pillared Hardtop | HR78 x 14 BSW | HR78 x 14 BSW | HR78 x 14 BSW |
| 4-Door Station Wagon | HR78 x 14 BSW | HR78 x 14 BSW | HR78 x 14 BSW |
| GRAN TORINO | | | |
| 2-Door Hardtop | HR78 x 14 BSW | HR78 x 14 BSW | HR78 x 14 BSW |
| 4-Door Pillared Hardtop | HR78 x 14 BSW | HR78 x 14 BSW | HR78 x 14 BSW |
| 4-Door Station Wagon | HR78 x 14 BSW | HR78 x 14 BSW | HR78 x 14 BSW |
| GRAN TORINO BROUGHAM | | | |
| 2-Door Hardtop | HR78 x 14 WSW | HR78 x 14 WSW | HR78 x 14 WSW |
| 4-Door Pillared Hardtop | HR78 x 14 WSW | HR78 x 14 WSW | HR78 x 14 WSW |
| GRAN TORINO SQUIRE | | | |
| 4-Door Squire Station Wagon | HR78 x 14 WSW | HR78 x 14 WSW | HR78 x 14 WSW |
| GRAN TORINO SPORT | | | |
| 2-Door Hardtop | HR78 x 14 WSW | HR78 x 14 WSW | HR78 x 14 WSW |

HR — Steel-belted radial ply tires.

OPTIONAL TIRE AVAILABILITY

| STANDARD TIRE | OPTIONAL TIRE | | | | | | |
|---------------------|-----------------|-----------------|------------------|------------------|------------------|----------------------------------|----------------------------------|
| | H78 x 14 BSW | H78 x 14 WSW | HR78 x 14 WSW | JR78 x 14 BSW | JR78 x 14 WSW | HR78 x 14 BSW 6-ply rated (b) | HR78 x 14 WSW 6-ply rated (b) |
| HR78 x 14 BSW | X | X | X | X (a) | X(a) | X | X |
| HR78 x 14 WSW | | X | | | X(a) | | X |

(a) Except Wagons.

(b) 6-ply rated HR78 x 14 available only on station wagons; all other tires 4-ply rated.

NOTE: See General Product Features for additional tire information.

TORINO GENERAL SPECIFICATIONS

ENGINE/AXLE RATIO SELECTIONS

| ENGINES | REAR AXLE RATIOS | | |
|----------------------|----------------------------|----------|------------------|
| | SELECTSHIFT CRUISE-O-MATIC | | |
| | STANDARD | OPTIONAL | TRACTION-LOK |
| 351 CID 2V V-8 | 3.00 | 3.25 | 3.00 3.25 |
| 400 CID 2V V-8 | 3.00 | 3.25 | 3.00 3.25 |
| 460 CID 2V V-8 | 2.75 | 3.00 | 2.75 (a) 3.00 |

(a) 3.00 standard in California. **NOTE:** Axle ratios are being revised throughout the year to improve fuel economy; to determine ratio from vehicle warranty label see page A-2.

WHEEL SPECIFICATIONS

| | |
|--|--|
| Type | Stamped Steel Ventilated Disc with Safety-Type Rims |
| Number of Studs | 5 |
| Diameter and Rim Width | |
| Standard Models | 14" x 5.5" |
| Models using JR78 x 14 (NA Wagons) | 14" x 6.0" |
| Optional 14" x 7.0" Magnum Wheels | all models, except Station Wagons. (NA with fender skirts.) |

STEERING SPECIFICATIONS

| | |
|--|--|
| Linkage Type | Parallelogram with Cross-Link and Idler Arm |
| Gear Type-Power, Recirculating Ball and Nut-Type | |
| Overall Steering Ratio-Power | 21.8:1 |
| Turning Diameter (Curb-to-Curb) | |
| -2-Door) | 41.3 ft. |
| -4-Door) | 41.3 ft. |
| Steering Wheel Diameter | 15.0-inch |
| Steering Wheel Turns (Lock-to-Lock) | |
| -Power) | 3.99 |

BRAKE SPECIFICATIONS (IN INCHES)

| FRONT DISC/REAR DRUM | ALL SEDANS | ALL STATION WAGONS |
|------------------------------------|--|-----------------------|
| Brake Rotor | | |
| Dia. (Disc) | 10.72 | 10.72 |
| Outer Working | | |
| Surface Dia. | 10.72 | 10.72 |
| Inner Working | | |
| Surface Dia. | 6.785 | 6.785 |
| Front Swept Area * | 211.9 sq.in. | 211.9 sq.in. |
| Drum Diameter/ Width | 10 x 2.5 | 11 x 2.25 |
| Rear Swept Area | 157 sq.in. | 155 sq.in. |
| Total Front and Rear Swept Area | 368.9 sq.in. | 366.9 sq.in. |
| Lining Material | Molded Asbestos | |
| Lining Attachment | Riveted | |
| Parking Brake— Type | Mechanical Actuation of Rear Brakes | |

* Swept Area is the effective working surface

CURB WEIGHTS

| MODEL | CURB* WEIGHT |
|------------------------------------|-----------------|
| TWO-DOOR HARDTOPS | |
| Torino | 4241 |
| Gran Torino | 4250 |
| Gran Torino Brougham | 4331 |
| Gran Torino Sport | 4286 |
| FOUR-DOOR PILLARED HARDTOPS | |
| Torino | 4315 |
| Gran Torino | 4335 |
| Gran Torino Brougham | 4372 |
| STATION WAGONS | |
| Torino | 4608 |
| Gran Torino | 4609 |
| Gran Torino Squire | 4634 |

* Weight of vehicle with oil, water and a full tank of gas.

TORINO GENERAL SPECIFICATIONS

BODY DIMENSIONS

| TORINO MODEL | 4-Door Pillared Hardtops | | | 2-Door Hardtops | | | | Station Wagons | | |
|--|--------------------------|-------------|----------------------|-----------------|-------------|----------------------|-------------------|----------------|-------------|--------------------|
| | Torino | Gran Torino | Gran Torino Brougham | Torino | Gran Torino | Gran Torino Brougham | Gran Torino Sport | Torino | Gran Torino | Gran Torino Squire |
| All dimensions in inches unless otherwise specified. | | | | | | | | | | |
| GENERAL | | | | | | | | | | |
| Wheelbase | 118 | 118 | 118 | 114 | 114 | 114 | 114 | 118 | 118 | 118 |
| Tread – Front | 63.4 | 63.4 | 63.4 | 63.4 | 63.4 | 63.4 | 63.4 | 63.4 | 63.4 | 63.4 |
| – Rear | 63.5 | 63.5 | 63.5 | 63.5 | 63.5 | 63.5 | 63.5 | 63.1 | 63.1 | 63.1 |
| Height – Overall | 53.2 | 53.2 | 53.2 | 52.5 | 52.5 | 52.5 | 52.5 | 54.8 | 54.8 | 54.8 |
| Length – Overall | 217.6 | 217.6 | 217.6 | 213.6 | 213.6 | 213.6 | 213.6 | 222.6 | 222.6 | 222.6 |
| Width – Overall | 79.3 | 79.3 | 79.3 | 79.3 | 79.3 | 79.3 | 79.3 | 79.0 | 79.0 | 79.0 |
| FRONT SEAT ROOM | | | | | | | | | | |
| Head room(effective) | 38.3 | 37.8 | 37.8 | 37.3 | 37.3 | 37.2 | 37.2 | 38.4 | 38.1 | 38.0 |
| Maximum leg room to accelerator | 42.5 | 41.9 | 41.9 | 41.9 | 42.1 | 41.9 | 42.1 | 42.5 | 42.1 | 41.9 |
| Hip room | 59.2 | 59.2 | 59.2 | 59.2 | 59.2 | 59.2 | 58.9 | 58.9 | 58.9 | 58.9 |
| Shoulder room | 58.6 | 58.5 | 58.5 | 58.5 | 58.5 | 58.5 | 58.5 | 58.5 | 58.5 | 58.5 |
| Steering wheel to thigh clearance | 4.0 | 3.4 | 3.4 | 4.0 | 3.6 | 3.4 | 3.4 | 4.0 | 3.6 | 3.4 |
| REAR SEAT (OR WAGON 2ND SEAT) | | | | | | | | | | |
| Head room(effective) | 36.9 | 36.9 | 36.9 | 36.2 | 36.3 | 36.2 | 36.1 | 38.4 | 38.4 | 38.3 |
| Minimum effective leg room | 37.8 | 37.5 | 37.5 | 33.2 | 33.0 | 33.0 | 33.0 | 37.3 | 37.1 | 37.0 |
| Hip room | 59.2 | 59.2 | 59.2 | 57.8 | 57.8 | 57.8 | 57.8 | 59.2 | 59.2 | 59.2 |
| Shoulder room | 58.5 | 58.5 | 58.5 | 56.9 | 56.9 | 56.9 | 56.9 | 58.5 | 58.5 | 58.5 |
| 3RD SEAT ROOM | | | | | | | | | | |
| Head room(effective) | – | – | – | – | – | – | – | 37.3 | 37.3 | 37.3 |
| Leg room(effective) | – | – | – | – | – | – | – | 31.1 | 31.1 | 31.1 |
| Hip room | – | – | – | – | – | – | – | 38.0 | 38.0 | 38.0 |
| Shoulder room | – | – | – | – | – | – | – | 48.4 | 48.4 | 48.4 |
| LUGGAGE COMPARTMENT | | | | | | | | | | |
| Usable luggage capacity(cu.ft.) | 16.5 | 16.5 | 16.5 | 16.5 | 16.5 | 16.5 | 16.5 | – | – | – |
| Lift – over height | 29.2 | 29.2 | 29.2 | 29.2 | 29.2 | 29.2 | 29.2 | – | – | – |
| CARGO COMPARTMENT | | | | | | | | | | |
| Cargo volume(cu.ft.) | – | – | – | – | – | – | – | 84.9 * | 84.9 * | 84.9 * |
| Maximum floor length(open tailgate) | – | – | – | – | – | – | – | 109.5 | 109.5 | 109.5 |
| Load floor length(closed tailgate) | – | – | – | – | – | – | – | 87.5 | 87.5 | 87.5 |
| Maximum rear opening width | – | – | – | – | – | – | – | 51.0 | 51.0 | 51.0 |
| Rear opening height | – | – | – | – | – | – | – | 28.8 | 28.8 | 28.8 |
| Minimum floor width (between wheelhousings) | – | – | – | – | – | – | – | 48.2 | 48.2 | 48.2 |
| GLASS AREA(Sq.In.) | | | | | | | | | | |
| Windshield glass exposed surface area | 1383.8 | 1383.8 | 1383.8 | 1383.8 | 1383.8 | 1383.8 | 1383.8 | 1383.8 | 1383.8 | 1383.8 |
| Side glass exposed surface area | 1307.5 | 1307.5 | 1307.5 | 1104.5 | 1104.5 | 1104.5 | 1104.5 | 2370.2 | 2370.2 | 2370.2 |
| Backlite glass exposed surface area | 887.0 | 887.0 | 887.0 | 887.0 | 887.0 | 887.0 | 887.0 | 577.4 | 577. | 577.4 |
| Total glass exposed surface area | 3578.3 | 3578.3 | 3578.3 | 3375.3 | 3375.3 | 3375.3 | 3375.3 | 4331.4 | 4331.4 | 4331.4 |

*Additional 8.1 cubic feet for underfloor storage.

TORINO COLOR AND TRIM SELECTIONS

Exterior and interior color combination shown as "available" have been established as most attractive to the average customer. Orders for combinations not shown may be submitted, provided the original order carries a notation stating the exterior and interior selection has been verified and is definitely desired. This procedure does not apply to orders specifying two-tone paint combinations or vinyl roof colors. Colors and codes referenced are the same as those shown in your Color and Trim Book.

| EXTERIOR & INTERIOR TRIM COMBINATIONS | MODELS | TORINO | | | GRAN TORINO | | | | | | | | GRAN TORINO SPORT | | | | | | | | | | | | | | | |
|---|----------------------------|---|------|-----|---|------|-------|-----|------------------------|------|-------|-----|---------------------------------------|-------------|-------------|-----------------------------|-------|------|-----|------------|-------------|-------------|--------------|-------|------|-----|------------|-------------|
| | | 2 DOOR HARDTOP 4-DOOR PILLARED HARDTOP | | | 2-DOOR HARDTOP 4-DOOR PILLARED HARDTOP | | | | 2-DOOR HARDTOP | | | | ALL-VINYL FLIGHT BENCH (OPTIONAL) | | | ALL-VINYL BUCKET (STANDARD) | | | | | | | | | | | | |
| | | ALL-VINYL BENCH (STANDARD) | | | CLOTH AND VINYL BENCH (STANDARD) | | | | VINYL BENCH (OPTIONAL) | | | | VINYL BENCH W/WHITE (2-DR) (OPTIONAL) | | | | | | | | | | | | | | | |
| | | Black | Blue | Tan | Black | Blue | Green | Tan | Black | Blue | Green | Tan | White/Blue | White/Black | White/Green | White/Saddle | Black | Blue | Tan | White/Blue | White/Black | White/Green | White/Saddle | Black | Blue | Tan | White/Blue | White/Black |
| AA | AB | AU | BA | BB | BC | BU | CA | CB | CG | CU | CQ | CW | C5 | C9 | EA | EB | EU | EQ | EW | E5 | E9 | DA | DB | DU | DQ | DW | D5 | D9 |
| EXTERIOR BODY COLORS | | | | | | | | | | | | | | | | | | | | | | | | | | | | |
| 1C | Black | | | | | | | | | | | | | | | | | | | | | | | | | | | |
| 2B | Bright Red | | | | | | | | | | | | | | | | | | | | | | | | | | | |
| 2M | Dark Red | | | | | | | | | | | | | | | | | | | | | | | | | | | |
| 3G | Dark Blue Metallic | | | | | | | | | | | | | | | | | | | | | | | | | | | |
| 3M* | Silver Blue Glow | | | | | | | | | | | | | | | | | | | | | | | | | | | |
| 3Q | Pastel Blue | | | | | | | | | | | | | | | | | | | | | | | | | | | |
| 4T* | Green Glow | | | | | | | | | | | | | | | | | | | | | | | | | | | |
| 4V | Dark Yellow Green Metallic | | | | | | | | | | | | | | | | | | | | | | | | | | | |
| 47 | Light Green | | | | | | | | | | | | | | | | | | | | | | | | | | | |
| 5J* | Ginger Glow | | | | | | | | | | | | | | | | | | | | | | | | | | | |
| 5T | Saddle Bronze Metallic | | | | | | | | | | | | | | | | | | | | | | | | | | | |
| 5U* | Tan Glow | | | | | | | | | | | | | | | | | | | | | | | | | | | |
| 5Y | Dark Copper Metallic | | | | | | | | | | | | | | | | | | | | | | | | | | | |
| 6D | Pastel Yellow | | | | | | | | | | | | | | | | | | | | | | | | | | | |
| 8C | Medium Gold Metallic | | | | | | | | | | | | | | | | | | | | | | | | | | | |
| 9D | Polar White | | | | | | | | | | | | | | | | | | | | | | | | | | | |

*RPO

| EXTERIOR & INTERIOR TRIM COMBINATIONS | MODELS | GRAN TORINO BROUGHAM | | | | | | | | | | | STATION WAGONS | | | | | | | | | | | | | | | |
|---|----------------------------|--|------|-------|-----|--------|----------------------------------|------|-------|-----|--------|------------|---|-------------|--------------|--------------------------------|-------|-----|----------------------------------|---------------|-----|--------|----------------------------------|-------|-----|------|-------|-----|
| | | 2-DOOR HARDTOP 4-DOOR PILLARED HARDTOPS | | | | | | | | | | | TORINO | | | GRAN TORINO GRAN TORINO SQUIRE | | | | SQUIRE (Only) | | | | | | | | |
| | | CLOTH AND VINYL SPLIT BENCH (STANDARD) | | | | | ALL VINYL SPLIT BENCH (OPTIONAL) | | | | | | ALL VINYL SPLIT BENCH W/WHITE (2-DR) (OPTIONAL) | | | ALL VINYL BENCH (STANDARD) | | | DURAWEAWE VINYL BENCH (OPTIONAL) | | | | ALL VINYL SPLIT BENCH (OPTIONAL) | | | | | |
| | | Black | Blue | Green | Tan | Saddle | Black | Blue | Green | Tan | Saddle | White/Blue | White/Black | White/Green | White/Saddle | Blue | Green | Tan | Blue | Green | Tan | Saddle | Blue | Green | Tan | Blue | Green | Tan |
| FA | FB | FG | FU | FZ | GA | GB | GC | GU | GZ | GQ | GW | G5 | G9 | AB | AG | AU | CB | CG | CU | CZ | RB | RG | RU | GB | GG | GU | GZ | |
| EXTERIOR BODY COLORS | | | | | | | | | | | | | | | | | | | | | | | | | | | | |
| 1C | Black | | | | | | | | | | | | | | | | | | | | | | | | | | | |
| 2B | Bright Red | | | | | | | | | | | | | | | | | | | | | | | | | | | |
| 2M | Dark Red | | | | | | | | | | | | | | | | | | | | | | | | | | | |
| 3G | Dark Blue Metallic | | | | | | | | | | | | | | | | | | | | | | | | | | | |
| 3M* | Silver Blue Glow | | | | | | | | | | | | | | | | | | | | | | | | | | | |
| 3Q | Pastel Blue | | | | | | | | | | | | | | | | | | | | | | | | | | | |
| 4T* | Green Glow | | | | | | | | | | | | | | | | | | | | | | | | | | | |
| 4V | Dark Yellow Green Metallic | | | | | | | | | | | | | | | | | | | | | | | | | | | |
| 47 | Light Green | | | | | | | | | | | | | | | | | | | | | | | | | | | |
| 5J* | Ginger Glow | | | | | | | | | | | | | | | | | | | | | | | | | | | |
| 5T | Saddle Bronze Metallic | | | | | | | | | | | | | | | | | | | | | | | | | | | |
| 5U* | Tan Glow | | | | | | | | | | | | | | | | | | | | | | | | | | | |
| 5Y | Dark Copper Metallic | | | | | | | | | | | | | | | | | | | | | | | | | | | |
| 6D | Pastel Yellow | | | | | | | | | | | | | | | | | | | | | | | | | | | |
| 8C | Medium Gold Metallic | | | | | | | | | | | | | | | | | | | | | | | | | | | |
| 9D | Polar White | | | | | | | | | | | | | | | | | | | | | | | | | | | |

*RPO

TORINO COLOR AND TRIM SELECTIONS

Exterior and interior color combination shown as "available" have been established as most attractive to the average customer. Orders for combinations not shown may be submitted, provided the original order carries a notation stating the exterior and interior selection has been verified and is definitely desired. This procedure does not apply to orders specifying two-tone paint combinations or vinyl roof colors. Colors and codes referenced are the same as those shown in your Color and Trim Book.

| ROOF COLOR INTERIOR COLORS & CODES | | LEVANT GRAIN | | | | | | | | | | | | | | | | | | | | | | | | | | | |
|---|------------------------|--------------|-------|-----|---------|-------|------|-------|--------|-----|--------|---------|---------|----------|-------|------|--------|-------|-------|---------|-----|-----|--------|----------|-----|--------|----------|--|--|
| | | BLACK | | | WHITE | | | | | | | | | BLUE | | | GREEN | | | BROWN | | | TAN | | | | | | |
| | | Black | Green | Tan | W/Black | Black | Blue | Green | Saddle | Tan | W/Blue | W/Black | W/Green | W/Saddle | Black | Blue | W/Blue | Black | Green | W/Green | Tan | Tan | Saddle | W/Saddle | Tan | Saddle | W/Saddle | | |
| | | A | G | U | W | A | B | G | Z | U | Q | W | 5 | 9 | A | B | Q | A | G | 5 | U | U | Z | 9 | U | Z | 9 | | |
| EXTERIOR BODY COLORS | | | | | | | | | | | | | | | | | | | | | | | | | | | | | |
| 1C | Black | • | | • | • | | | | | | | | | | | | | | | | | | | | | | | | |
| 2B | Bright Red | • | | | • | • | | | | | | | | | | | | | | | | | | | | | | | |
| 2M | Dark Red | • | | | • | • | | | | | | | | | | | | | | | | | | | | | | | |
| 3G | Dark Blue Metallic | | | | | • | | | | | | | | | | • | • | | | | | | | | | | | | |
| 3M* | Silver Blue Glow | • | | | | • | | | | | | | | | | • | • | • | | | | | | | | | | | |
| 3Q | Pastel Blue | | | | | • | | | | | | | | | | • | • | | | | | | | | | | | | |
| 4T* | Green Glow | • | • | | | • | | • | | | | | | | | | | | • | • | • | | | | | | | | |
| 4V | Dark Yellow Green Met. | • | • | | | | • | | | | | | | | | | | • | • | • | | | | | | | | | |
| 5J* | Ginger Glow | | | | | | | • | • | | | | | • | | | | | | | | • | • | • | • | • | • | | |
| 5T | Saddle Bronze Metallic | | | | | | | • | • | | | | | • | | | | | | | | • | • | • | • | • | • | | |
| 5U* | Tan Glow | | | | | | | • | • | | | | | • | | | | | | | | • | • | • | • | • | • | | |
| 5Y | Dark Copper Metallic | • | | | | | | • | • | | | | | • | | | | | | | | • | • | • | • | • | • | | |
| 6D | Pastel Yellow | • | | | • | • | | | | | | | | | | | | | | | | • | • | | | | | | |
| 8C | Medium Gold Metallic | • | | | | • | | | • | • | | | | • | | | | | | | | • | • | • | • | • | • | | |
| 9D | Polar White | • | | | • | • | • | • | • | • | • | • | • | • | • | • | • | • | • | • | • | • | • | • | • | • | • | | |

*RPO †Gran Torino Elite ††NA Gran Torino Elite

| VINYL ROOF COLOR CODE | | |
|-----------------------|---------|---------|
| Black—A | Brown—T | Tan—U |
| White—W | Blue—B | Green—G |

1975 FORD Torino



Gran Torino...

value leader of the mid-size market

Gran Torino Brougham...

distinctive luxury for the discriminating buyer

Gran Torino Sport...

bred to be exciting, spirited and beautiful

Gran Torino . . . value leader of the mid-size market.
Gran Torino Brougham . . . distinctive luxury for the
discriminating buyer. Gran Torino Sport . . . bred to
be exciting, spirited and beautiful.
1975 Torino . . . continues a tradition of offering the

mid-size car buyer a wide choice of models, solid
value, high luxury, and sporty styling. The 1975 Torino
has been refined to include a higher level of standard
equipment and continues to offer a wide range of
optional equipment.

TORINO...THE MID-SIZE CAR FOR TODAY'S NEW-CAR BUYER

FORD TORINO FOR 1975



Gran Torino... SOLID VALUE WITH A HIGH LEVEL OF STANDARD EQUIPMENT

Across-the-board Standard Features

351 CID 2V V-8 ENGINE

Previously optional, now standard, the husky 351 2V V-8 engine is famous for its smooth, powerful response and long-life durability.

SELECTSHIFT AUTOMATIC TRANSMISSION

The popular 3-speed SelectShift automatic transmission is now standard and features a second gear that may be selected manually for better traction on ice or snow.

POWER FRONT DISC BRAKES

Stopping a Torino is sure and positive with the standard power front disc brakes.

POWER STEERING

Torino's standard power steering makes handling nice and easy... and parking a snap!

STEEL-BELTED RADIAL PLY TIRES

Standard steel-belted radial ply tires (HR78 x 14) offer long tread

life and less rolling resistance which can improve gas mileage.

SOLID-STATE IGNITION

Solid-state ignition is now standard on every Torino and its reliable, practically maintenance-free electronic components replace the former distributor points, cam and condenser.

Gran Torino Brougham... luxury was never this beautiful

The handsome Brougham interior is highlighted by:

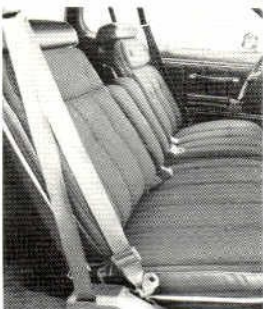

- split bench seat convenience with dual fold-down center armrests
- luxurious and easy-to-clean Westminster cloth seat trim or super-soft all-vinyl trim
- attractive woodtone applique on the instrument panel
- self-regulating electric clock
- deluxe 2-spoke steering wheel

Luxury Brougham exterior features include:

- full-vinyl roof
- distinctive opera window (2-door models only)
- "Brougham" stand-up hood ornament
- deluxe wheel covers
- wide vinyl insert bodyside molding that's color-keyed to the vinyl roof and helps to protect against dings and dents

Gran Torino Sport... the Torino with "spirit"

In a league of its own, the Gran Torino Sport has distinctive exterior and interior features. Exterior-wise, the Gran Torino Sport can be identified by its "sport grille ornament," "Turbine" wheel covers, dual fender peak paint stripes, and dual outside color-keyed left- and right-hand remote-control mirrors.



Inside, the sporty mood prevails because the Gran Torino Sport driver is greeted by a full array of instrumentation to tell him how all major systems are functioning. Included is a tachometer, trip odometer, gauges for oil pressure, ampere, temperature and fuel, and an electric self-regulating clock. Other sporty amenities include super-soft easy-to-clean vinyl door and seat trim, a deluxe 2-spoke steering wheel, plush cut-pile carpeting and body-hugging comfortable bucket seats or Flight Bench seating at no extra cost.

MAJOR 1975 TORINO SPECIFICATIONS

MODEL LINE-UP

Low Series—Torino

- 2-Dr. Hardtop
- 4-Dr. Pillared Hardtop

Middle Series—Gran Torino

- 2-Dr. Hardtop
- 4-Dr. Pillared Hardtop

Luxury Series—Gran Torino Brougham

- 2-Dr. Hardtop
- 4-Dr. Pillared Hardtop

Sport Series—Gran Torino Sport

- 2-Dr. Hardtop

Wagon Series

- Torino
- Gran Torino
- Gran Torino Squire

10 models in 1975 to satisfy every mid-size buyer's needs!

TORINO POWER TEAM LINE-UP

[351 CID 2V V-8 engine and automatic transmission are standard.]

| ENGINE | TRANSMISSION | AXLE RATIO | | |
|----------------|--------------|------------|------|------------------|
| | | Std. | Opt. | Traction-Lok |
| 351 CID 2V V-8 | automatic | 3.00 | 3.25 | 3.00 3.25 |
| 400 CID 2V V-8 | automatic | 3.00 | 3.25 | 3.00 3.25 |
| 460 CID 4V V-8 | automatic | 2.75 (a) | 3.00 | 2.75 (a) 3.00 |

(a) 3.00 standard in California.

Note: Torino Fuel Tank Capacities are: Torino 26.5 gal.
Wagons 21.2 gal.

1975 TORINO STANDARD TIRE AVAILABILITY

| MODEL AND ENGINE APPLICATION | 351 CID 2V 8-CYLINDER | 400 CID 2V 8-CYLINDER | 460 CID 4V 8-CYLINDER |
|---|--------------------------|--------------------------|--------------------------|
| TORINO (All models) | HR78 x 14 BSW | HR78 x 14 BSW | HR78 x 14 BSW |
| GRAN TORINO (All models) | HR78 x 14 BSW | HR78 x 14 BSW | HR78 x 14 BSW |
| GRAN TORINO BROUGHAM (All models) | HR78 x 14 WSW | HR78 x 14 WSW | HR78 x 14 WSW |
| GRAN TORINO SQUIRE | HR78 x 14 WSW | HR78 x 14 WSW | HR78 x 14 WSW |
| GRAN TORINO SPORT | HR78 x 14 WSW | HR78 x 14 WSW | HR78 x 14 WSW |

HR — Steel-belted radial ply tires.

OPTIONAL TIRE AVAILABILITY

| STANDARD TIRE | OPTIONAL TIRE | | | | | | |
|-------------------------|-----------------|-----------------|------------------|------------------|------------------|----------------------------------|----------------------------------|
| | H78 x 14 BSW | H78 x 14 WSW | HR78 x 14 WSW | JR78 x 14 BSW | JR78 x 14 WSW | HR78 x 14 BSW 6-ply rated (b) | HR78 x 14 WSW 6-ply rated (b) |
| HR78 x 14 BSW | X | X | X | X (a) | X (a) | X | X |
| HR78 x 14 WSW | | X | | | X (a) | | X |

(a) Except Wagons.

(b) 6-ply rated HR78 x 14 available only on station wagons; all other tires 4-ply rated.

NOTE: See General Product Features for additional tire information.

1975 TORINO TRADEMARKS...

□ ECONOMY...

□ PRACTICALITY...

□ DURABILITY...

TORINO ECONOMY... Standard Features

- steel-belted radial ply tires have a long tread life, offer less rolling resistance and can increase gasoline mileage
- solid-state ignition system eliminates distributor points and condenser . . . parts that previously had to be serviced or replaced
- self-adjusting brakes eliminate the need for periodic brake adjustments and thereby saves the owner added service expense
- long recommended service maintenance intervals provide for owner convenience . . . and driving economy



Steel-Belted Radial Ply Tires

TORINO PRACTICALITY... Standard Features

- roomy big-car six-passenger seating, especially good for car pools
- 3-speed automatic transmission provides convenience and smooth acceleration
- power steering offers more positive handling control and parking convenience
- fade-resistant power front disc/rear drum brakes help provide smooth, straight-line stops with minimum pedal effort
- 26.5-gallon gas tank capacity (21.2 on wagons) for long non-stop travel between fill-ups
- 16.5-cubic-foot luggage compartment for family-size travel convenience
- DirectAire ventilation provides a continuous circulation of fresh air
- steering column lock helps protect against theft and vandalism
- reversible keys
- inside hood release adds owner security and helps protect against engine-compartment tampering
- concealed 2-speed electric windshield wipers with wiper-mounted washer jets for an even distribution of the cleaning solution
- lockable glove box
- inside day/night mirror, for added driver convenience and comfort
- 16 exterior colors to satisfy practically every prospect's taste



Self-adjusting Front Disc/Rear Drum Brakes

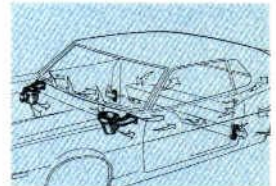

DirectAire Ventilation



16.5-Cubic-Foot Luggage Compartment

TORINO DURABILITY... Standard

- solid body/frame construction with rubber insulators to help isolate passengers from noise, vibration and harshness
- rust protection on all underbody parts to help resist corrosion
- extensive use of sealers, insulation and soundproofing materials to reduce road and engine noise
- aluminized muffler for long life
- impact-resistant, high-strength, heat-tempered glass (on sides and backlite)
- strong two-sheet "sandwich," heat-laminated windshield



Aluminized Muffler

MORE TORINO QUALITY FEATURES

Electrostatic paint process works on electrical principles that cause the paint to be attracted to the surface and achieve a thorough "wraparound" effect. The result is a paint finish that is deep, rich, and long-lasting.

Selected front coil springs and calibrated shock absorbers mean that Torino's front springs are "computer-selected" to match the weight requirements of every car with the shock

absorbers calibrated to provide optimum dampening.

Four-link Stabul rear suspension improves stability of the car by helping to resist lateral or side-to-side sway—and permits the coil springs to provide a maximum cushioning effect.

Quality workmanship in every Torino shows up in the careful fit of body panels, doors, interior trim, the vinyl roof and the snug fit of carpeting.

TORINO OPTIONS TO MAKE THE "GOING" EVEN BETTER!

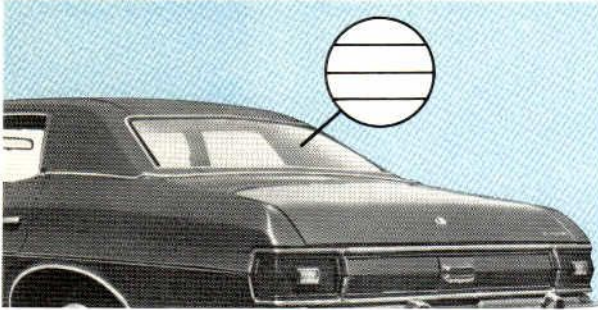

The practical electric rear window defroster option quickly melts ice and removes mist.

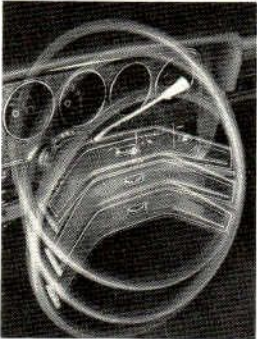

The Tilt Steering Wheel option allows the driver to select the most comfortable of five steering wheel angles. For easy entry and exit, the steering wheel can be placed in the maximum "up" position.

Here's a fine convenience option, especially for long-mileage drivers. The Fingertip Speed Control lets the driver choose and hold a safe cruising speed. It disengages at the touch of the brake pedal or by pressing the "off" rocker switch located on the left-hand spoke of the steering wheel.



This new option gives the passenger added convenience by providing one light on each side of the visor vanity mirror.

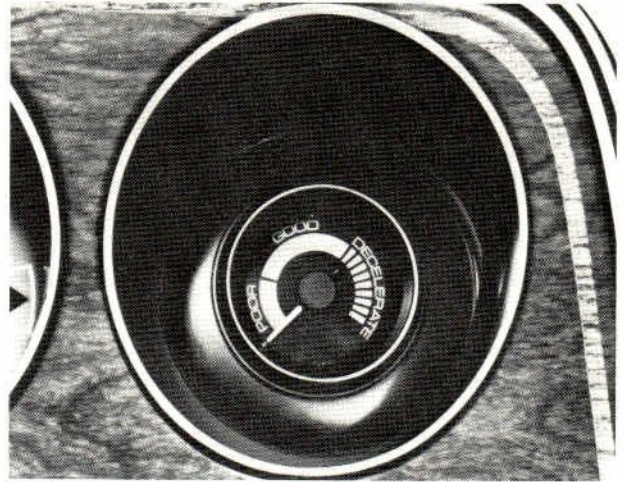

The Fuel Sentry Vacuum Gauge option will help the concerned driver modify his driving habits and improve gasoline economy. The idea is to keep the needle in the green area of the gauge (good, excellent economy) and out of the red area (poor economy) by driving with a "light foot." This option is not available on the Gran Torino Sport.

POWER ASSISTS

Power door locks, electrical — includes power tailgate lock on wagons.

Power seat, 6-way driver only — available only with Gran Torino Brougham, and the Gran Torino Squire with the Squire Brougham Option.

Power seat, 6-way full width — not available on Gran Torino Brougham models.

Power side windows — includes front windows only on 2-door models.

Power tailgate window — standard on Gran Torino Squire model. Available only on station wagon models.

OTHER POPULAR TORINO OPTIONS

The Convenience Group Includes:

- left- and right-hand remote-controlled mirrors. The right-hand mirror is controlled from the instrument panel
- right-hand visor vanity mirror
- interval windshield wipers
- spare tire extractor (station wagons only)

The Light Group includes these convenience and safety features:

- ashtray light
- dual beam map light
- glove compartment light
- luggage compartment light
- cargo light (station wagons)
- under instrument panel courtesy light
- engine compartment light

- rear door courtesy light switch
- headlights-on warning buzzer
- headlight switch illumination
- parking brake warning light

SelectAire or Automatic Temperature Control Air Conditioner

Both air conditioner options provide comfortable temperature and humidity control. The Tinted Glass option is recommended with either air conditioner system to help reduce sun glare and heat build-up.

AM/FM Stereo Radio

The optional AM/FM stereo radio features 10 station pre-set tuning, four-speaker sound distribution (two door-mounted and two rear shelf-mounted) . . . and a pleasurable world of listening entertainment.

FORD TORINO WAGONS OFFER

- PRACTICALITY...
- ROOMINESS...
- VALUE...

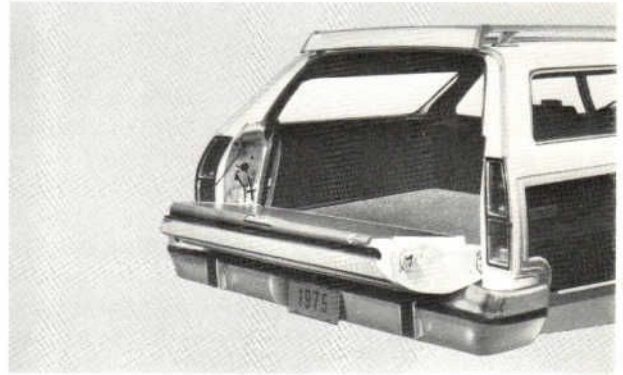
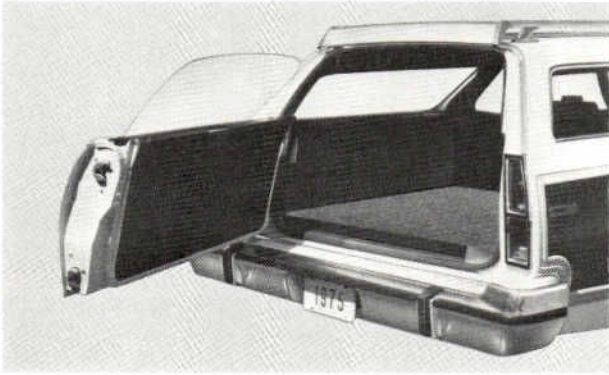

Torino Wagons offer:

- wide 48.2 inches of loadspace between wheel-housings
- fold-down second seat for a long load floor length of 87.5 inches with the tailgate up . . . 109.2 inches with the tailgate down
- 84.9 cubic foot cargo volume with a carpeted load floor
- lockable storage compartment under the load floor adds 8.1 cubic feet of storage space



3-Way Magic Doorgate

The ultimate in station wagon practicality and convenience, Torino's popular 3-Way Magic Doorgate opens like a door with the window up or down . . . or opens like a tailgate for extra long loads.



All the Torino Wagons have as standard equipment:

- 351 CID 2V V-8 engine which combines good performance with operating economy
- SelectShift Automatic Transmission that offers driving convenience
- Power Steering which provides good handling response and ease of parking
- Power front disc brakes which provide smooth, straight-line stops with minimum pedal effort
- Steel-belted radial ply tires for long tread life
- Solid-state ignition system to help reduce scheduled maintenance costs

POPULAR 1975 TORINO WAGON OPTIONS

- Power tailgate window allows the driver to raise or lower the window from the driver's seat
- Electric rear window defroster quickly helps to clear the rear window of ice, snow and mist
- Fingertip Speed Control lets the driver select and hold a safe cruising speed
- Tilt Steering Wheel for maximum drive comfort and convenience
- Heavy-duty suspension to help handle heavy loads
- Trailer Towing Packages (Class II or III) to handle

- trailer towing requirements
- Traction-Lok Differential to help transverse snow, mud and sandy roads
- Air Conditioning
- Tinted glass to help reduce sun-glare and heat build-up
- 400 CID 2V V-8 engine for added performance
- HR78 x 14 WSW tires (standard on Gran Torino Squire)
- Power Door Locks (Includes power tailgate lock)



The Luxurious Squire Brougham Option

- split bench seat convenience with dual fold-down center armrests
- super-soft comfortable and easy-to-clean vinyl seat and door trim
- plush 22-oz. cut-pile carpeting in the passenger compartment
- cut-pile carpet on the load floor
- electric clock
- deluxe wheel covers
- stand-up "Brougham" hood ornament

Spare Tire Extractor

This option makes it extra easy to remove the spare tire from its stowage compartment—standard with the Convenience Group.

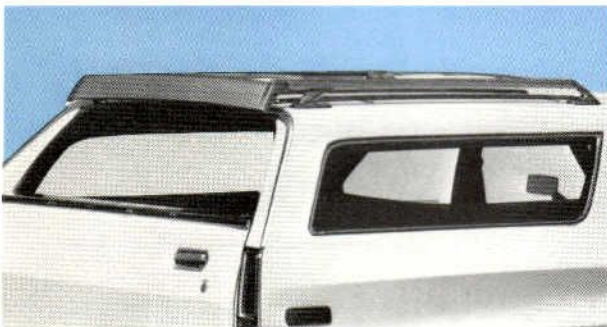
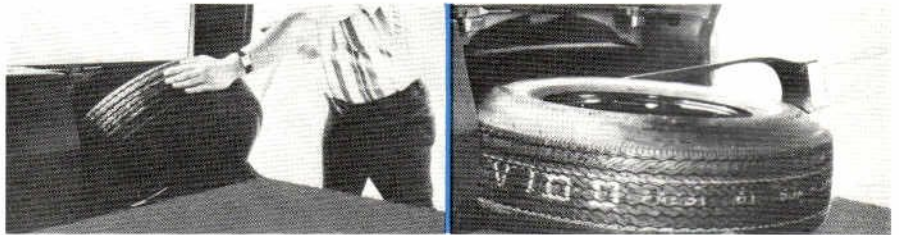

Deluxe Luggage Rack

This convenience option features wide, strong steel side rails with a rear crossbar that is fully adjustable for partial or full loads. A built-in air deflector is included which directs an air stream over the rear window to help prevent the accumulation of dirt deposits.



Rear-Facing Third Seat

Here's how to provide additional passenger room in the Gran Torino or Gran Torino Squire Wagons. The Rear-Facing Third Seat option offers the convenience of added seating space when raised or, when closed, the panel may be locked to provide lockable luggage space.

1975 TORINO BODY DIMENSIONS

| (All dimensions in inches unless otherwise specified.) TORINO MODEL | 4-Door Pillared Hardtops | | | 2-Door Hardtops | | | |
|---|--------------------------|-------------|----------------------|-----------------|-------------|----------------------|-------------------|
| | Torino | Gran Torino | Gran Torino Brougham | Torino | Gran Torino | Gran Torino Brougham | Gran Torino Sport |
| GENERAL | | | | | | | |
| Wheelbase | 118 | 118 | 118 | 114 | 114 | 114 | 114 |
| Tread—Front | 63.4 | 63.4 | 63.4 | 63.4 | 63.4 | 63.4 | 63.4 |
| —Rear | 63.5 | 63.5 | 63.5 | 63.5 | 63.5 | 63.5 | 63.5 |
| Height—Overall | 53.2 | 53.2 | 53.2 | 52.5 | 52.5 | 52.5 | 52.5 |
| Length—Overall | 217.6 | 217.6 | 217.6 | 213.6 | 213.6 | 213.6 | 213.6 |
| Width—Overall | 79.3 | 79.3 | 79.3 | 79.3 | 79.3 | 79.3 | 79.3 |
| FRONT SEAT ROOM | | | | | | | |
| Headroom (effective) | 38.3 | 37.8 | 37.8 | 37.6 | 37.3 | 37.2 | 37.2 |
| Maximum legroom to accelerator | 42.5 | 41.9 | 41.9 | 42.5 | 42.1 | 41.9 | 41.9 |
| Hip Room | 59.4 | 59.4 | 59.4 | 59.4 | 59.4 | 59.4 | 56.7 |
| Shoulder Room | 58.6 | 58.6 | 58.6 | 58.6 | 58.6 | 58.6 | 58.6 |
| REAR SEAT | | | | | | | |
| Headroom (effective) | 36.9 | 36.9 | 36.9 | 36.2 | 36.3 | 36.2 | 36.1 |
| Minimum effective legroom | 37.8 | 37.5 | 37.5 | 33.2 | 33.0 | 33.0 | 33.0 |
| Hip Room | 59.4 | 59.4 | 59.4 | 58.0 | 58.0 | 58.0 | 58.0 |
| Shoulder Room | 58.5 | 58.5 | 58.5 | 56.9 | 56.9 | 56.9 | 56.9 |
| LUGGAGE COMPARTMENT | | | | | | | |
| Usable luggage capacity (cu. ft.) | 16.5 | 16.5 | 16.5 | 16.5 | 16.5 | 16.5 | 16.5 |

| STATION WAGONS | Torino | Gran Torino | Gran Torino Squire |
|--|--------|-------------|--------------------|
| GENERAL | | | |
| Wheelbase | 118 | 118 | 118 |
| Tread—Front | 63.4 | 63.4 | 63.4 |
| —Rear | 63.2 | 63.2 | 63.2 |
| Height—Overall | 54.8 | 54.8 | 54.8 |
| Length—Overall | 222.6 | 222.6 | 222.6 |
| Width—Overall | 79.0 | 79.0 | 79.0 |
| FRONT SEAT ROOM | | | |
| Headroom (effective) | 38.4 | 38.1 | 38.0 |
| Max. legroom to accelerator | 42.5 | 42.1 | 41.9 |
| Hip Room | 59.4 | 59.4 | 59.4 |
| Shoulder Room | 58.6 | 58.6 | 58.6 |
| WAGON 2ND SEAT | | | |
| Headroom (effective) | 38.4 | 38.4 | 38.3 |
| Legroom (effective) | 37.3 | 37.1 | 37.0 |
| Hip Room | 59.3 | 59.3 | 59.3 |
| Shoulder Room | 58.4 | 58.4 | 58.4 |
| 3RD SEAT ROOM | | | |
| Headroom (effective) | 37.3 | 37.3 | 37.3 |
| Legroom (effective) | 31.1 | 31.1 | 31.1 |
| Hip Room | 38.0 | 38.0 | 38.0 |
| Shoulder Room | 48.4 | 48.4 | 48.4 |
| CARGO COMPARTMENT | | | |
| Cargo Volume (cu. ft.) | 84.9* | 84.9* | 84.9* |
| Maximum floor length (open tailgate) | 109.5 | 109.5 | 109.5 |
| Load Floor Length (closed tailgate) | 87.5 | 87.5 | 87.5 |
| Maximum rear opening width | 51.0 | 51.0 | 51.0 |
| Rear opening height | 28.8 | 28.8 | 28.8 |
| Minimum floor width (between wheel housings) | 48.2 | 48.2 | 48.2 |

NOTE: In order to achieve the emissions standards established for 1975 model vehicles, catalytic converters will be installed on all 1975 Torinos with all engines.

FORD Torino

for 1975



At the time of release, specifications and prices contained herein are believed to be correct. Ford Division reserves the right to discontinue models at any time or change specifications, designs or prices without incurring obligation.

*Additional 8.1 cubic feet for underfloor storage.